

## 8.0L - V10 Fuel Injection

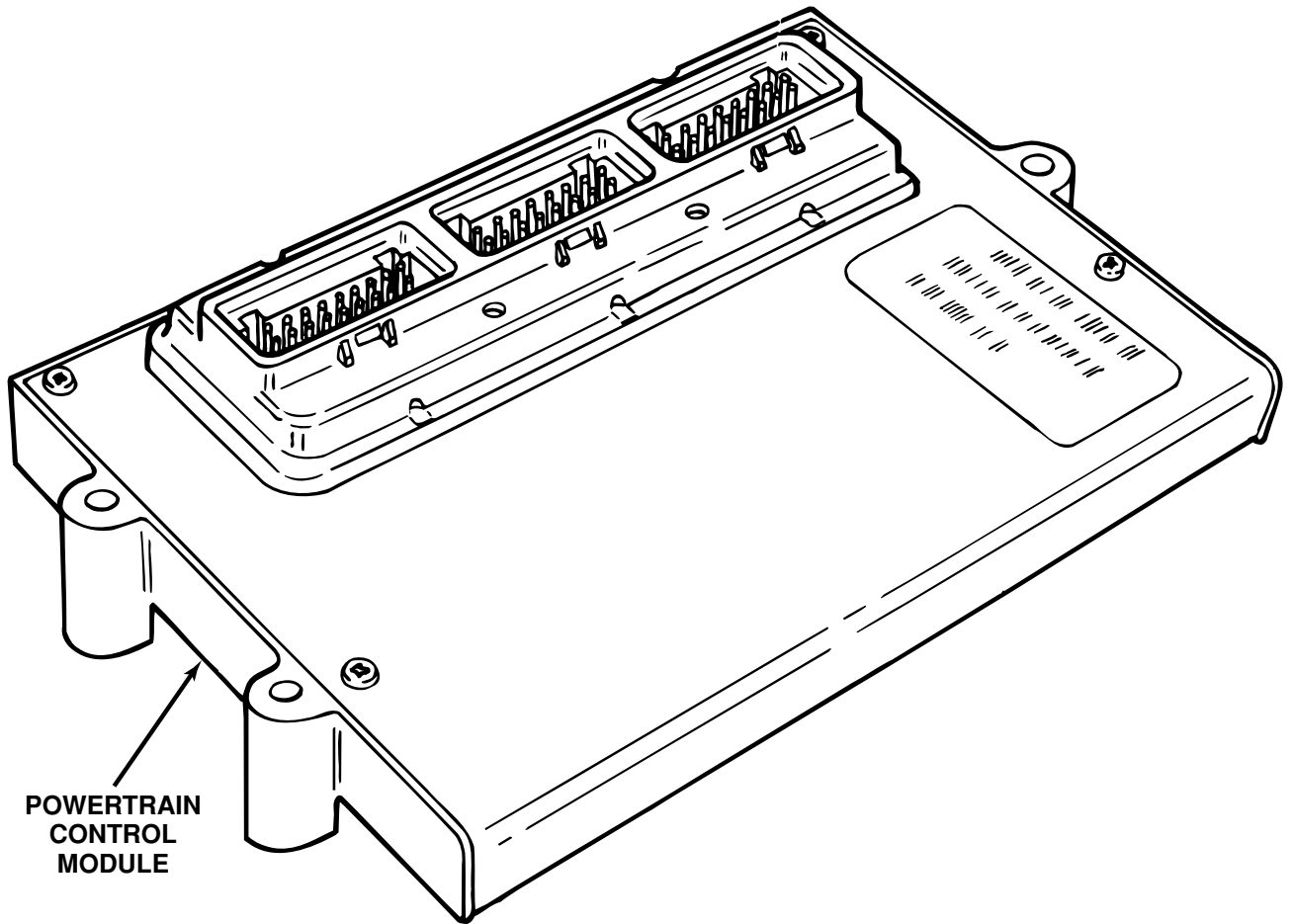

## ***8.0L – V10 Fuel Injection***

---

# 8.0L – V10 Fuel Injection

## TABLE OF CONTENTS

<b>LESSON 1: INTRODUCTION</b> .....	1
Student Learning Objectives .....	1
General Description .....	2
Acronym List .....	3
Powertrain Control Module (PCM) .....	4
General PCM Information .....	5
Speed Density .....	6
Fuel Delivery System .....	8
Emissions System .....	8
Idle Control Systems.....	9
Charging Control Systems .....	9
1996 Viper Roadster.....	9
1996 BR/Viper Coupe .....	9
1997 BR.....	9
Vehicle Speed Control Systems <del>BR</del> .....	9
Engine Cooling Control Systems <del>VIPER</del> .....	9
A/C Control Systems.....	10
Transmission Control <del>BR</del> .....	10
Transmission Control <del>SR</del> .....	10
Connector Repair.....	10
Diagnosis .....	10
Parts Required (1996 Only):.....	11
<b>LESSON 2:</b> .....	13
Fuel Tank.....	13
Fuel Pump Module .....	14
Check Valve Operation.....	15
Fuel Pressure Regulator .....	17
Fuel Flow .....	17
SR.....	20
BR .....	20
Fuel Pump Relay .....	19
Fuel Injectors .....	20
Fuel Filter .....	21
Fuel Lines and Rail.....	21
Fuel Lines .....	21
Fuel Rail .....	22
Throttle Body .....	23
<i>ACTIVITY 1 — Fuel System Test</i> .....	24

# 8.0L – V10 Fuel Injection

<b>LESSON 3: POWERTRAIN CONTROL MODULE</b> .....	26
Power Supplies and Grounds .....	26
CCD Bused Messages .....	28
Data Link Connector .....	28
<i>ACTIVITY 2 — PCM Power And Grounds</i> .....	31
<b>LESSON 4: FUEL INJECTION SYSTEM — PCM INPUTS</b> .....	32
Crankshaft Position Sensor .....	32
Crankshaft Position Sensor Service .....	35
Camshaft Position Sensor (CMP) .....	36
Cam/Crank Diagnosis .....	38
Camshaft Position Sensor Service .....	38
<i>ACTIVITY 3 — Camshaft Position Sensor Activity</i> .....	39
BR .....	39
SR.....	40
Manifold Absolute Pressure (MAP) Sensor .....	41
SR.....	44
BR .....	44
MAP Sensor Diagnostics .....	45
MAP Sensor Limp-in.....	45
Component Locations .....	46
<i>ACTIVITY 4 — Manifold Absolute Pressure (MAP) Sensor</i> .....	47
BR .....	47
SR.....	48
Throttle Position Sensor (TPS) .....	49
TPS Programs .....	50
Idle .....	50
Off-Idle .....	50
Acceleration .....	50
Wide Open Throttle (WOT) .....	51
Deceleration .....	51
Wide Open Throttle Fuel Cutoff During Cranking .....	51
TPS Diagnostics .....	51
TPS Limp-in .....	51
<i>ACTIVITY 5 — Throttle Position Sensor</i> .....	52
Engine Coolant Temperature (ECT) Sensor .....	53
96 Coupe and 97 All Viper .....	53
BR .....	53
ECT Sensor Diagnostics .....	56
ECT Sensor Limp-in .....	56
<i>ACTIVITY 6 — Engine Coolant Temperature Sensor</i> .....	57
BR .....	57
SR.....	58

## 8.0L – V10 Fuel Injection

Intake Air Temperature (IAT) Sensor .....	59
IAT Sensor Diagnostics .....	60
IAT Sensor Limp-in .....	60
<i>ACTIVITY 7 — Intake Air Temperature Sensor</i> .....	61
Sensed Battery Voltage .....	62
Fuel Injectors .....	62
Charging Ⓡ(Truck/Coupe/97 Vipers) .....	62
Charging Ⓡ1996 Viper Roadster .....	62
Oxygen (O2) Sensors .....	63
General Information .....	63
Stoichiometric Ratio .....	65
Catalyst .....	66
Upstream O2 Sensor .....	67
O2 Sensor Electrical Operation .....	68
O2 Sensor Diagnostics .....	68
<i>ACTIVITY 8 — Upstream O2 Sensor</i> .....	70
Downstream O2 Sensor .....	71
BR (Medium Duty) OBD II Vehicles .....	71
OBD II .....	71
Catalyst Monitor .....	71
O2 Monitor .....	71
O2 Sensor Heater Monitor .....	72
Adaptive Memories .....	72
Short-Term Adaptive Memory .....	72
Long-Term Adaptive Memory .....	73
Purge-Free Cells .....	75
Purge Corruption Reset Feature .....	75
DRB III Display .....	76
<i>ACTIVITY 9 — Fuel Adaptive Memory</i> .....	77
Park/Neutral Switch (Auto transmission Only) .....	78
OBD II Rationality Test .....	79
Brake Switch .....	80
Clutch Pedal Position Switch .....	80
Component Location .....	81
Vehicle Speed Sensor (VSS) .....	82
Vehicle Speed Sensor Diagnostics .....	82
Fuel-Level Sensor Input .....	83
Battery/Ambient Temperature Sensor .....	84
BR/96 Coupe/97 Viper .....	84
1996 Viper Roadster .....	84
Battery Temperature Sensor Diagnostics .....	85
Air Conditioning Switch .....	87
Stall Torque Management ⓇR .....	88

# 8.0L – V10 Fuel Injection

Transmission-Fluid Temperature Sensor <del>BR</del> .....	88
Transmission-Governor Pressure Sensor <del>BR</del> .....	88
Transmission-Output Shaft Speed Sensor <del>BR</del> .....	88
<i>ACTIVITY 10 — PCM Inputs</i> .....	89
<b>LESSON 5: FUEL INJECTION SYSTEM — PCM OUTPUTS</b> .....	90
Solenoid and Relay Control .....	90
Automatic Shutdown Relay (ASD) .....	91
Fuel Pump Relay .....	94
Fuel Injectors .....	95
Fuel Injector Diagnostics .....	96
<i>ACTIVITY 11 — Fuel Pump/Fuel Injectors</i> .....	97
Ignition Coils .....	98
Coil Operation .....	99
PCM Operation .....	100
Spark Plug <del>BR</del> .....	100
Idle Air Control (IAC) Stepper Motor .....	101
Description .....	101
Operation .....	101
IAC Stepper Motor Program .....	104
Target Idle .....	105
IAC Motor Position .....	105
IAC Stepper Motor Service .....	105
IAC Diagnostics .....	105
<i>ACTIVITY 12 — IAC Motor</i> .....	106
Radiator Fan Relays <del>SR</del> .....	107
Radiator Fan ON Relay .....	107
Radiator Fan Low/High Relay .....	107
Generator Field Control (Except 96 Roadster) .....	108
Charging System Indicator Light (Gen. Lamp) <del>Except 96 Roadster</del> .....	110
Tachometer .....	110
Torque Converter Clutch Solenoid (Auto Trans Only) .....	110
Overdrive Lamp <del>BR</del> .....	111
Transmission Relay <del>BR</del> .....	111
Three-Four Shift Solenoid <del>BR</del> .....	111
Reverse Lockout Solenoid <del>SR</del> .....	111
First To Fourth Gear Shift Indicator Lamp <del>SR</del> .....	111
Skip Shift Solenoid <del>SR</del> .....	111
Governor Pressure Solenoid <del>BR</del> .....	112
Malfunction Indicator Lamp (MIL) .....	112
Trip Definition <del>SR/97BR</del> .....	112
Evaporative Purge Solenoid .....	113
Leak-Detection Pump Solenoid (Starting in 1998) .....	113
Speed-Control Servo Solenoids .....	113

# 8.0L – V10 Fuel Injection

<b>LESSON 6: EMISSIONS CONTROL SYSTEMS</b> .....	114
Evaporative Emission Control .....	114
Fuel Filler Cap .....	115
Rollover Valves .....	115
Evaporative Charcoal Canister .....	115
Duty-Cycle Purge Solenoid .....	115
Fuel-Vapor Recovery System (Duty-Cycle Purge Control) .....	115
Leak Detection Pump (Beginning in 1998) .....	117
Crankcase Ventilation (CCV) System <del>NR</del> .....	118
Positive Crankcase Ventilation (PCV) System <del>NR</del> .....	119
<b>LESSON 7: VEHICLE SPEED CONTROL SYSTEM — BR</b> .....	120
System Operation .....	120
Speed Control Switch Operation .....	120
Speed Control Servo .....	122
Speed Control Switch Input .....	123
Multiplexing .....	123
Brake Switch .....	123
Adaptive Learning Strategy .....	124
Interactive Speed Control .....	125
When Climbing a Grade .....	125
Downshift Delay .....	125
Grade Hunting .....	125
When Descending a Grade (Overspeed Reduction) .....	126
<b>LESSON 8: AIR CONDITIONING CONTROLS</b> .....	127
Instrument Panel A/C Select Switch .....	127
Air-Conditioning Request Signal .....	127
A/C Compressor Clutch Relay .....	127
<b>LESSON 9: TRANSMISSION ELECTRONICS</b> .....	129
Automatic Transmission General Description .....	129
Functional Operation .....	129
Powerflow .....	130
Torque Converter Electronics .....	130
Recommend Fluid .....	130
Electronic Governor Components .....	130
Governor Pressure Solenoid Valve .....	130
Governor Pressure Sensor .....	132
Governor Body and Transfer Plate .....	133
Transmission Fluid Temperature Thermistor .....	133
Transmission Speed Sensor .....	134
Throttle Position Sensor .....	135

## **8.0L – V10 Fuel Injection**

Powertrain Control Module (PCM) .....	135
Governor Pressure Curves .....	135
Sensor Calibration .....	135
Governor Pressure Transducer Zero-Pressure Offset .....	135
Normal Governor-Pressure Transducer Calibration .....	136
Cold Governor-Pressure Transducer Calibration .....	136
Transmission Shifting .....	136
Overdrive Off Switch .....	137
3-4 Shift Sequence .....	138
Manual Transmission General Description <b>Ⓜ</b> VIPER .....	139
Skip Shift Solenoid .....	139
Reverse Lockout Solenoid .....	139



# ***8.0L – V10 Fuel Injection***

---

# ***8.0L – V10 Fuel Injection***

## **LESSON 1**

### **INTRODUCTION**

#### **STUDENT LEARNING OBJECTIVES**

Upon completion of this course, the technician will be able to:

- Use a DRB III and/or MDS to interpret the signals generated by the various input sensors, as displayed on these tools.
- Use the service manual procedure to properly depressurize the fuel system, attach the appropriate test equipment, and test fuel system pressure.
- Given a vehicle equipped with a V10 engine, the appropriate Service Manual and Powertrain Diagnostics manual, the technician will be able to properly diagnose electrical and mechanical malfunctions of inputs and outputs to the Powertrain Control Module.
- Use a DVOM on vehicle to measure, record, and interpret the voltage/resistance of various PCM-related system inputs and outputs.

# 8.0L – V10 Fuel Injection

## GENERAL DESCRIPTION

This publication contains information regarding the systems controlled by the Powertrain Control Module (PCM). These include fuel, emissions, speed control, charging, radiator fan, PCM-related A/C control functions, and PCM-related transmission control functions on all the 1996 and 1997 vehicles equipped with a V10 engine. This includes the Ram Pickup and the Viper. However, there are two different variations of fuel control components for each of these vehicles.

The Ram pickup cast iron V10 comes as either a Medium Duty or Heavy Duty version. The Medium Duty is California OBDII compliant. This means it is equipped with four O2 sensors; two for fuel control and two for OBDII catalyst diagnostics. With downstream O2 sensors the PCM uses downstream O2 fuel control.

The Heavy Duty version meets Federal emissions without OBDII. These vehicles have only 2 upstream O2 sensors.

In 1996 the Viper aluminum V10 has different components from Roadster to Coupe. The Roadster has a rear-of-engine mounted thermostat and twin throttle cables.

The Coupe has a front-of-engine mounted thermostat, single throttle cable with synchronization shaft, and is OBDII compliant.

In 1997 both vipers will utilize similar components and systems as the 1996 Coupe.

The fuel system for all these engines utilizes a speed density sequential multiport fuel injection system, to deliver precise amounts of fuel to each cylinder. Fuel for all vehicles is delivered by an in-tank pump module.

All engines use a distributorless ignition. The PCM controls the ignition and fuel injector operation and provides outputs to fuel and ignition components to promote the most efficient operation possible.

**NOTE:** *Early 1997 PCMs have an eight-digit part number and operate like a 1996 PCM. Later 1997 models have a 10-digit part number.*

# 8.0L – V10 Fuel Injection

## ACRONYM LIST

- Air Bag Control Module — ACM
- Air Conditioning — A/C
- Auto Shutdown Relay — ASD relay
- Barometric Pressure — Baro
- Battery Temperature Sensor — BTS
- Body Control Module — BCM
- Camshaft Position Sensor — CMP sensor
- Chrysler Collision Detection Bus — CCD
- Crankcase Ventilation System — CCV
- Crankshaft Position Sensor — CKP sensor
- Data Link Connector — DLC
- Diagnostic Trouble Code — DTC
- Digital Multimeter — DMM
- Duty Cycle Purge Solenoid — DCP solenoid
- Electrically Erasable Programmable Read-Only Memory — EEPROM
- Engine Coolant Temperature Sensor — ECT sensor
- Engine Position Pulse — EPP
- High Density Polyethylene — HDPE
- Idle Air Control Motor — IAC motor
- Intake Air Temperature Sensor — IAT sensor
- Jeep®/Truck Engine Controller — JTEC
- Leak Detection Pump — LDP
- Malfunction Indicator Light — MIL
- Manifold Absolute Pressure Sensor — MAP sensor
- Mopar Diagnostic System — MDS
- Mechanical Instrument Cluster — MIC
- Negative Temperature Co-efficient — NTC
- Oxygen Sensor — O<sub>2</sub> Sensor
- Park/Neutral — P/N
- Positive Temperature Coefficient — PTC
- Power Distribution Center — PDC
- Powertrain Control Module — PCM
- Throttle Position Sensor — TPS
- Transmission Control Module — TCM
- Vehicle Speed Sensor — VSS
- Vehicle Theft Security System — VTSS

# 8.0L – V10 Fuel Injection

## POWERTRAIN CONTROL MODULE (PCM)

Introduced in 1996, the Jeep<sup>®</sup>/Truck Engine Controller (JTEC), also known as the Powertrain Control Module (PCM) does not require air to flow through the controller for cooling (fig. 1).

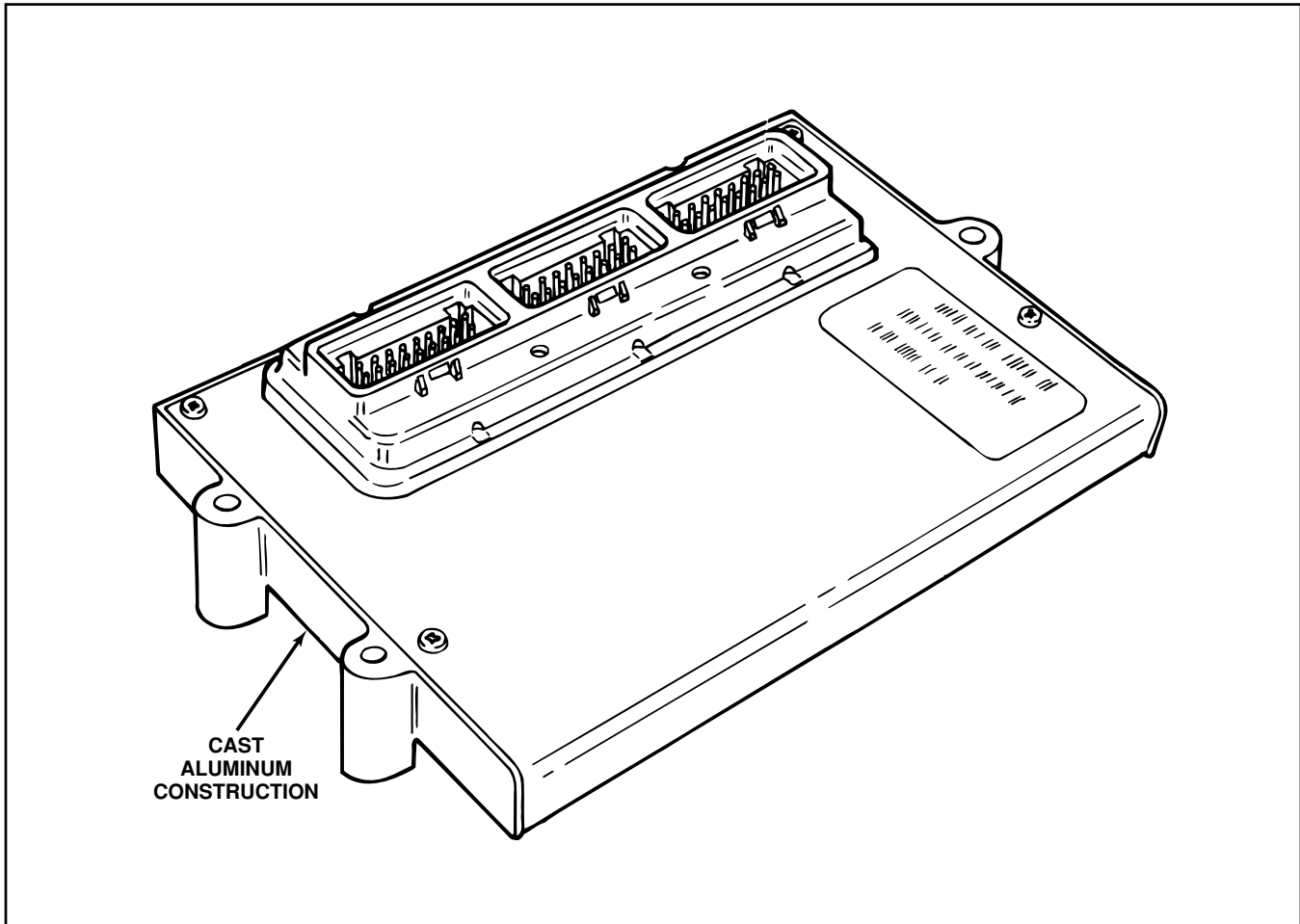

Figure 1 Motorola Powertrain Control Module

The changes to the PCM from previous Chrysler controllers include:

- Increased memory
  - 2k '96
  - 4k '97
- Increased speed at which the processor runs:
  - Clock speed (8 MHz)
  - 16-bit microprocessor
  - Two 8-bit microprocessors
- Increased number of drivers to control outputs from 22 to 30.
- Increased number of terminals in the connector from 60 to three 32-way connectors (96 total).
- Gold-plated, low-insertion-force terminals (new tool No. 6934 required for servicing the terminals).
- Uses an Electrically Erasable Programmable Read-Only Memory (EEPROM) on all PCMs (flashable).

## **8.0L – V10 Fuel Injection**

The PCM is a multiprocessor unit, containing one 16-bit microprocessor and two 8-bit microprocessors. The PCM controls operation of the fuel, emissions, charging, idle, radiator fan, air conditioning and speed control systems. This is accomplished by the 16-bit processor, which transmits fuel and spark requirements to the two 8-bit processors, communicating with outside devices; and processing some of the analog inputs. One of the 8-bit processors controls fuel-injector timing pulses and some 1-bit inputs and outputs. The other 8-bit processor controls spark timing pulses, handles a few analog inputs and some 1-bit (on/off) inputs and outputs. After the PCM processes the information, it operates outputs regulating engine performance, ignition components, generator field, A/C compressor, radiator fan and speed control servo. This cycle of input/processing/output ensures that the engine meets emission, performance, fuel economy, driveability and customer expectations.

The JTEC PCM uses voltage level detection to determine when a switched device or circuit is present. This means that the internal circuit of an input is constructed in a way that there must be a specific voltage present to recognize a change. The voltage required is approximately 5 volts.

The analog to digital (A/D) converters are part of the micro-processors in the JTEC. The A/D converter changes the analog input signal from a sensor into a digital signal with the same value. The digital signal is then processed by the micro-processor.

### **GENERAL PCM INFORMATION**

Because the same basic controller is used on a wide variety of engine packages, it is necessary for the PCM to learn the options actually on the vehicle. This function is shown as “Learned Vehicle Configuration” on the DRB III. In order for the PCM and DRB III to diagnose and report faults, for items such as speed control and air conditioning, the PCM must see the input of the item at least once with the engine running. The PCM then knows that the vehicle is equipped with that option. This is important because if the DRB III does not show the item as equipped, it will not display any fault codes, even though they may be present in the PCM.

Anytime the direct battery is disconnected from the PCM, for approximately 60 seconds, the “Learned Vehicle Configuration” is erased. Erasing fault codes with the DRB III causes the PCM to perform a battery reset function if the PCM has an 8-digit number. This means that the previously mentioned configuration is erased, as well as all learned memory functions, such as Long Term Adaptive Memory and IAC steps. On 10-digit part numbered PCMs, erasing DTCs clears faults, freeze frames and similar conditions only.

# 8.0L – V10 Fuel Injection

## SPEED DENSITY

A speed density system measures the engine rpm, as well as the intake manifold absolute pressure. Coolant temperature and throttle position are necessary inputs also. In 1996, on the V10 engine speed density system, **both** the crankshaft and camshaft position inputs are needed to start and run the engine. The engine cannot run without them. The RPM signal tells the PCM how often to add fuel, while the Manifold Absolute Pressure (MAP) sensor input determines how much fuel the engine receives (fig. 2).

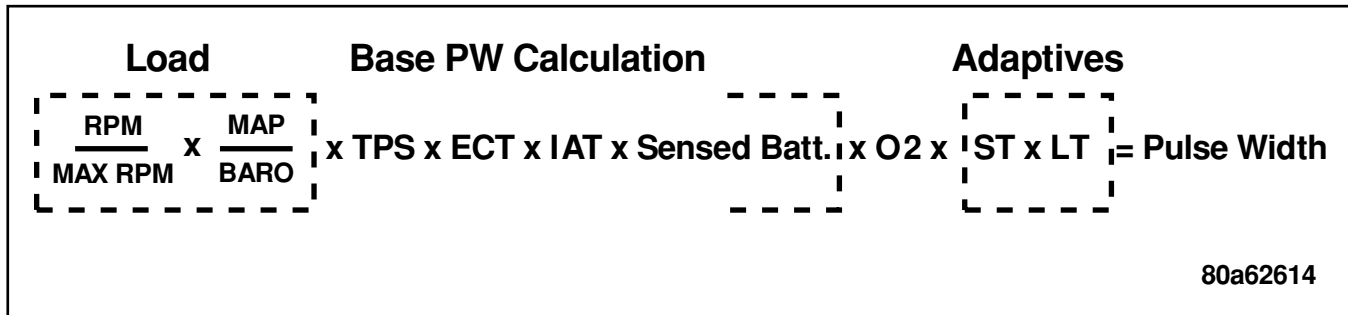

Figure 2 Speed Density Engine Management Strategy

For a speed density system to operate, the first and most important piece of information that must be determined is the amount of air that is entering the engine. To do this, the PCM looks first at the current rpm, divided by the MAX rpm. This allows the PCM to calculate the greatest volume of air entering the engine at that rpm. The PCM then looks at the present manifold vacuum, compared to the barometric pressure that was seen at key on. This gives the PCM the reference for current air pressure in the intake system. With these two pieces of information, the PCM determines the current load being placed on the engine. For instance, if rpm was low and vacuum nearly matched baro (WOT), then the PCM would know that the engine is under a heavy load and inhaling as much air as possible for that rpm.

The PCM uses the TPS to determine the current mode of operation such as idle, off-idle acceleration, WOT, or deceleration. The PCM uses this information to perform various operating strategies. If the TPS increases rapidly, the injectors will be fired longer to increase fuel flow. If the TPS is closed and the vehicle is moving, then the PCM will limit and/or close off injectors during coast down.

The PCM has to see a value for every sensor so that it can correctly calculate the pulse. If a sensor goes bad, a value must be substituted. For example, if the MAP sensor is bad, the PCM will use the TPS and rpm to make up a value to use as MAP.

The next modifier is Engine Coolant Temperature (ECT), which is the second biggest modifier of pulse width, after MAP. If the engine is cold, the fuel will not atomize easily. To overcome this problem, the PCM will add extra fuel, depending on the value from the ECT. Conversely, if the engine is very hot, fuel will be limited. ECT is also used for engine cooling control. If ECT becomes too high, the PCM will automatically turn on the cooling fan. If the ECT signal is lost, the PCM will substitute a preset (limp-in) value and turn the cooling fan on.

## ***8.0L – V10 Fuel Injection***

Intake Air Temperature (IAT) is also used to modify the amount of fuel delivered, although it is not as big a modifier as ECT. If ECT is high and IAT shows cold (dense air), then the PCM will add extra fuel. Another feature of IAT is that spark advance is limited, if the air is hot (thin). If the IAT signal is lost, the PCM will substitute a value based on Battery/Ambient Temperature sensor.

Sensed battery voltage is needed as a modifier because the injectors are rated for specific flow at a specific voltage. If the voltage is lower than what the injector was rated at, it will take longer for the injector to open, and it may not open as far. So the PCM needs to know the voltage, so that it can compensate by changing the pulse width on-time.

Up to this point, it is not necessary that any fuel was burned, and/or the PCM is in an open-loop operating condition.

After the fuel is delivered, the PCM looks at the O<sub>2</sub> signal to determine how well it did on the initial calculation. The O<sub>2</sub>S provides the PCM with the raw input, as to how much oxygen was left over, after the combustion process.

The adaptive memories allow the PCM to do two things. First, it gives it the capability to change the pulse width to bring the O<sub>2</sub>S to its mid-range of operation (short term). Second, it allows to store in memory corrections required for specific operating conditions (long term).

Based upon all of these inputs, the PCM delivers what it believes to be the optimum pulse width, to deliver the correct emissions performance, fuel economy, and driveability.



# 8.0L – V10 Fuel Injection

## FUEL DELIVERY SYSTEM

The fuel system receives fuel pressure from an in-tank pump module. The PCM controls the operation of the fuel system by providing battery voltage to the fuel pump through the fuel pump relay. The PCM requires only two inputs and a good ground to operate the fuel pump relay. The two inputs are:

- Ignition voltage.
- Crankshaft Position (CKP) sensor.

**NOTE:** *The PCM uses inputs from the CMP and CKP sensors to calculate engine speed.*

## EMISSIONS SYSTEM

The emissions system has several components, all used to lower the quantities of hydrocarbons (HC), carbon monoxide (CO) and oxides of nitrogen (NOx). Emissions systems are required not only to control the quantity of emissions out the tailpipe, but also any emissions that might be escaping into the atmosphere from the fuel system and engine. The emissions system includes:

- Evaporative control system
- Engine crankcase pressure-control system (positive crankcase pressure)
- Exhaust emissions

The PCM controls the evaporative emissions by the operation of a Duty-Cycle Purge (DCP) solenoid. The inputs required to control the DCP solenoid include:

- ECT sensor
- O2 Sensor
- TPS
- Engine speed
- MAP sensor
- Ambient/Battery Temperature sensor

The engine crankcase is ventilated by either a Crankcase Ventilation (CCV) system or a Positive Crankcase Ventilation (PCV) system. Neither is controlled by the PCM.

The exhaust emissions are controlled by the use of a catalytic converter, and almost every input and output of the PCM. The only inputs and outputs that DO NOT control emissions are:

- Speed-control switches and servo.
- Tachometer.
- Air Conditioning (A/C) request circuit, A/C relay, and the A/C pressure switches.
- ASD and fuel pump relays.

# 8.0L – V10 Fuel Injection

## **IDLE CONTROL SYSTEMS**

The PCM maintains a quality idle by controlling the Idle Air Control (IAC) motor. Inputs to the PCM required to operate the IAC motor include:

- TPS
- MAP sensor
- ECT sensor
- VSS
- Spark scatter (output)
- Park/Neutral switch
- A/C switch
- Ambient/Battery Temperature sensor

## **CHARGING CONTROL SYSTEMS**

### **1996 VIPER ROADSTER**

The PCM does not control the charging system on the Roadster. Charging system voltage control is performed by a regulator that is built into the generator.

### **1996 BR/VIPER COUPE/1997 ALL VIPER**

The PCM maintains battery voltage within a range of approximately 13.04 volts to 15.19 volts by providing battery voltage to the generator field through the ASD relay and by controlling the ground side of the generator field.

The inputs required to maintain the proper battery voltage are:

- Battery voltage
- BTS
- Engine speed

### **1997 BR**

The 1997 PCM maintains battery voltage within a range of approximately 13.04 volts to 15.19 volts by providing both battery voltage and ground to the generator field through the PCM.

## **VEHICLE SPEED CONTROL SYSTEMS – BR**

The PCM is designed to operate the speed control system to allow the driver of the vehicle to maintain a constant vehicle speed automatically. The speed control servo receives battery voltage directly from the PCM. The PCM on all vehicles operates the ground side of the vacuum and vents solenoids of the servo. The brake switch controls the dump solenoid. For more information, refer to the Vehicle Speed Control section of this publication.

## **ENGINE COOLING CONTROL SYSTEMS – VIPER**

To maintain engine temperature, the PCM controls the electric radiator fan, by providing battery voltage to the fan through the radiator fan ON and High/Low relays. The PCM controls the ground side of both fan relay coils. The PCM uses the following inputs to operate the radiator fan relays:

- ECT sensor
- A/C switch
- Vehicle speed

# 8.0L – V10 Fuel Injection

## A/C CONTROL SYSTEMS

Finally, the PCM uses the A/C Request and Select circuits to identify when to energize the A/C relay. The A/C relay provides the A/C compressor clutch with battery voltage, when energized. Besides the A/C Request and Select circuits, the PCM uses the following inputs to determine when the A/C relay should be energized:

- Engine speed
- A/C pressure switches
- TPS
- ECT sensor
- Engine Running Timer

## TRANSMISSION CONTROL – BR

The PCM controls operation of the converter clutch, overdrive clutch, and governor pressure solenoid. It determines transmission shift points based on input signals from the transmission thermistor, transmission speed sensor, engine speed sensor, vehicle speed sensor and throttle position sensor.

## TRANSMISSION CONTROL – SR

Although the Viper only comes with a manual transmission, the PCM still has some control functions that it performs. The PCM controls operation of the reverse lockout solenoid, first to fourth gear shift indicator and the skip shift solenoid.

**NOTE:** *The following pages of this student reference book describe each section in detail. The function and operation of the inputs and outputs are explained the first time each input or output is introduced. Subsequent sections will elaborate on any input or output not previously described.*

## CONNECTOR REPAIR

Poor electrical connections can cause intermittent electrical complaints which can be very difficult to diagnose. Once diagnosed, the repair can range from simply reconnecting an electrical connector to complete wiring harness replacement. The following drivetrain electrical connector repair components have recently been made available to aid in drivetrain electrical repairs without replacing a complete harness. If it is determined that a customer complaint could be related to a poor electrical connection, use the following diagnosis to inspect the electrical connectors.

### Diagnosis:

This information pertains to electrical connections for the following components:

- Throttle Position Sensor (TPS)
- Engine Coolant Temperature (ECT) Sensor and Gauge Sending Unit
- Oxygen (O<sub>2</sub>) Sensor
- Manifold Absolute Pressure (MAP) Sensor
- Crankshaft Position (CKP) Sensor
- Camshaft Position Sensor
- Vehicle Speed Sensor (VSS)
- Fuel Injector
- Ignition Coils
- Idle Air Control (IAC) Motor
- Purge Solenoid

## 8.0L – V10 Fuel Injection

Inspecting the connector begins with a thorough check of the insulator. If the insulator locking tab is damaged or broken, replace the insulator. If the insulator end seal or seal ring is damaged, replace the seal. Gently pull on one wire of the connector at a time. If the wire pulls out of the insulator, remove and inspect the wedge lock. Also inspect the locking tab inside the insulator. Replace the wedge lock if there are any signs of damage.

Inspect all wire terminals for corrosion. If corrosion is evident, replace the terminal ends and both insulator seals. To verify how securely the terminal fits to the component, insert and remove the harness side connector terminals onto the mating terminal of the component. Then, rotate the terminal 90°, 180° and 270° while inserting and removing the harness side connector terminal onto the pin(s) of the component. **Check each unique terminal-to-pin connection for any multi-terminal connector.**

If any connection is loose, replace the harness side connector terminal after verifying a good connection with the new terminal. For information regarding service procedures for electrical connectors, refer to Section 8W of the appropriate Service Manual.

### Parts Required (1996 Only):

Component	Insulator Part Number	Terminal Part Number	Wedge Lock Part Number	End Seal Part Number	Ring Seal Part Number
Throttle Position and Vehicle Speed Sensors	4450545	4625130	4450091	4450092	4450093
Manifold Absolute Pressure Sensor	4450090	4625130	4450091	4450092	4450093
Upstream Oxygen Sensor	4707126	4400110	N/A	N/A	N/A
Downstream Oxygen Sensor	4707127	4400110	N/A	N/A	N/A
Crank Position Sensor (MANUAL TRANSMISSION)	56016982	4604597	56016987	4414474	56016985
Crank Position Sensor (AUTO TRANSMISSION)	56016983	4604597	56016987	4414474	56016985
<b>Crank Position Sensor Retainer P/N 56016988</b>					
Camshaft Position Sensor	4414468	4604597	4414470	4414474	56017460
Engine Coolant Temperature Sensor	56006291	4558005	N/A	N/A	N/A

## **8.0L – V10 Fuel Injection**

<b>Component</b>	<b>Insulator Part Number</b>	<b>Terminal Part Number</b>	<b>Wedge Lock Part Number</b>	<b>End Seal Part Number</b>	<b>Ring Seal Part Number</b>
Engine Coolant Temperature Gauge Sending Unit	56006431	4558005	N/A	N/A	N/A
Intake Air Temperature Sensor	4414270	4331568	N/A	N/A	N/A
Oil Pressure Sensor	4414048	4625130	4414024	4414047	4414049
Fuel Injector	4604512	N/A	N/A	N/A	4604519
Ignition Coil	4481614	4625130	4414024	4414047	4414049
Idle Air Control Motor	56018428	4331568	N/A	N/A	N/A
Purge Solenoid	4661957	4604597	4661974	N/A	N/A
Transmission Solenoid	56017053	56017057	N/A	N/A	N/A

# 8.0L - V10 Fuel Injection

## LESSON 2

### FUEL TANK

Fuel tanks on both the BR and the SR are made of high density polyethylene (HDPE). Both tanks also incorporate a fuel pump module and rollover valve. On the BR, the tank is located on the driver's side of the vehicle. For the SR, the tank is located at the rear (fig 3).

The Coupe incorporates an access panel in the trunk compartment for fuel pump module service.

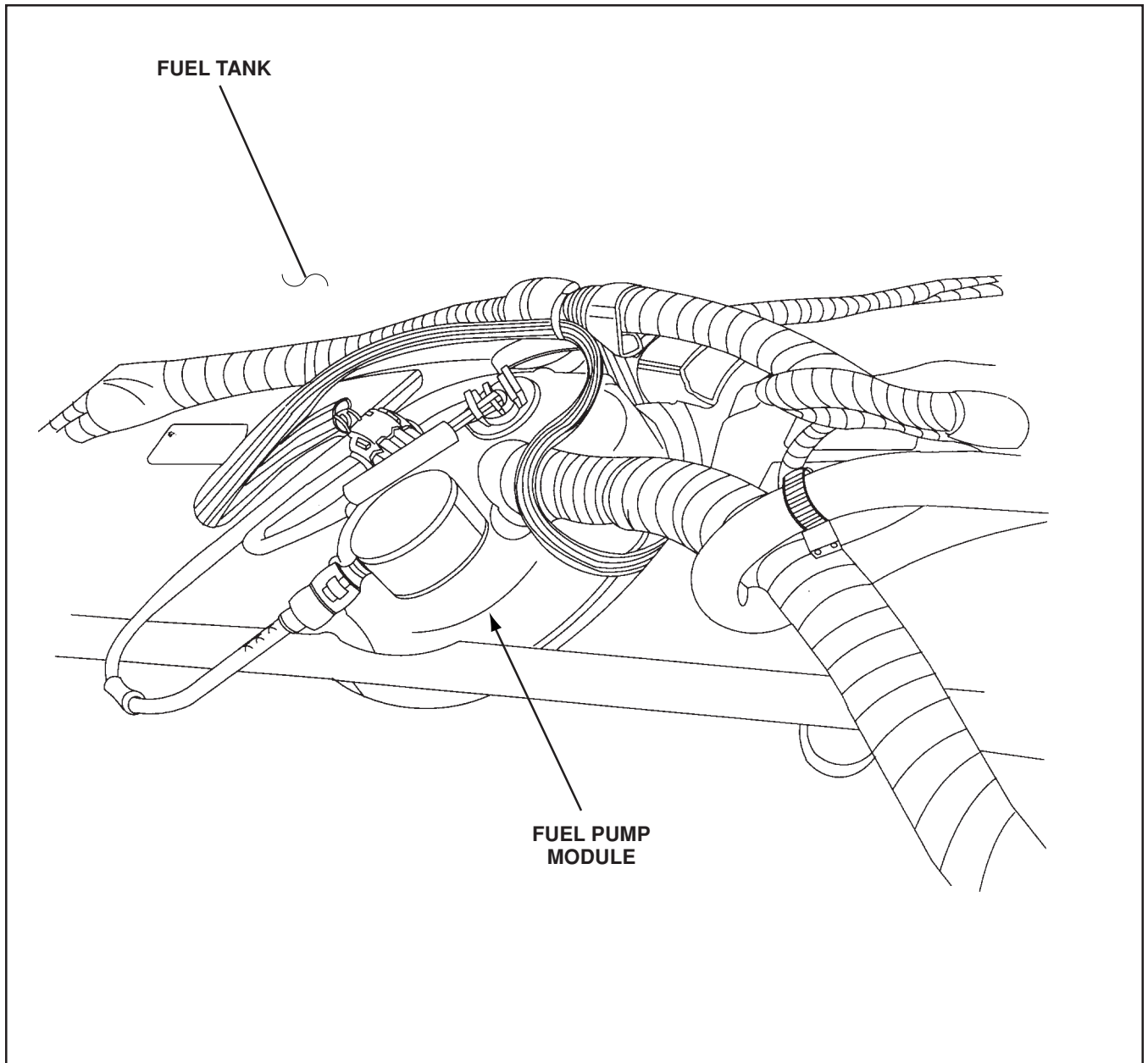

Figure 3 Fuel Tank (SR)

# 8.0L – V10 Fuel Injection

## FUEL PUMP MODULE

The Viper/Truck fuel pump module is an in-tank unit with an integral fuel-level sensor and pressure regulator. The pump is driven by a 12-volt DC motor, anytime the fuel pump relay is energized. Serviceable components on the module may be:

- Inlet strainer.
- Fuel level sensor.
- Fuel filter/pressure regulator.

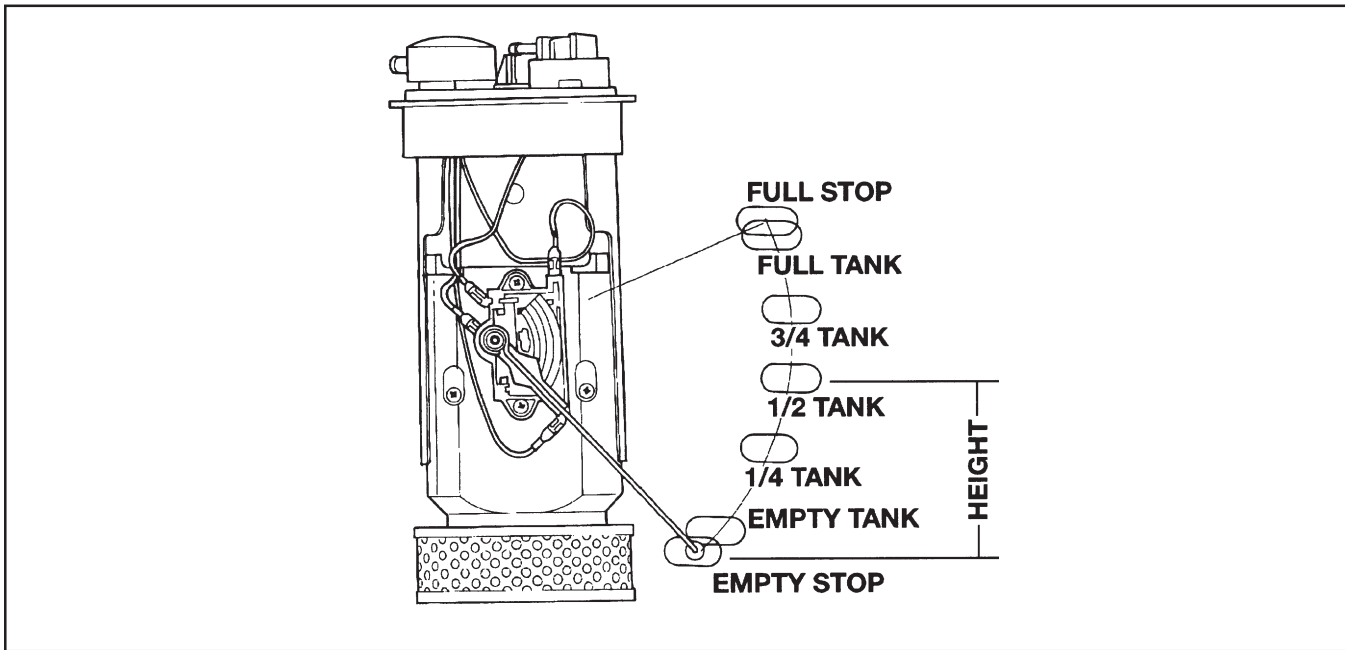

Figure 4 1996 SR Fuel Pump Module

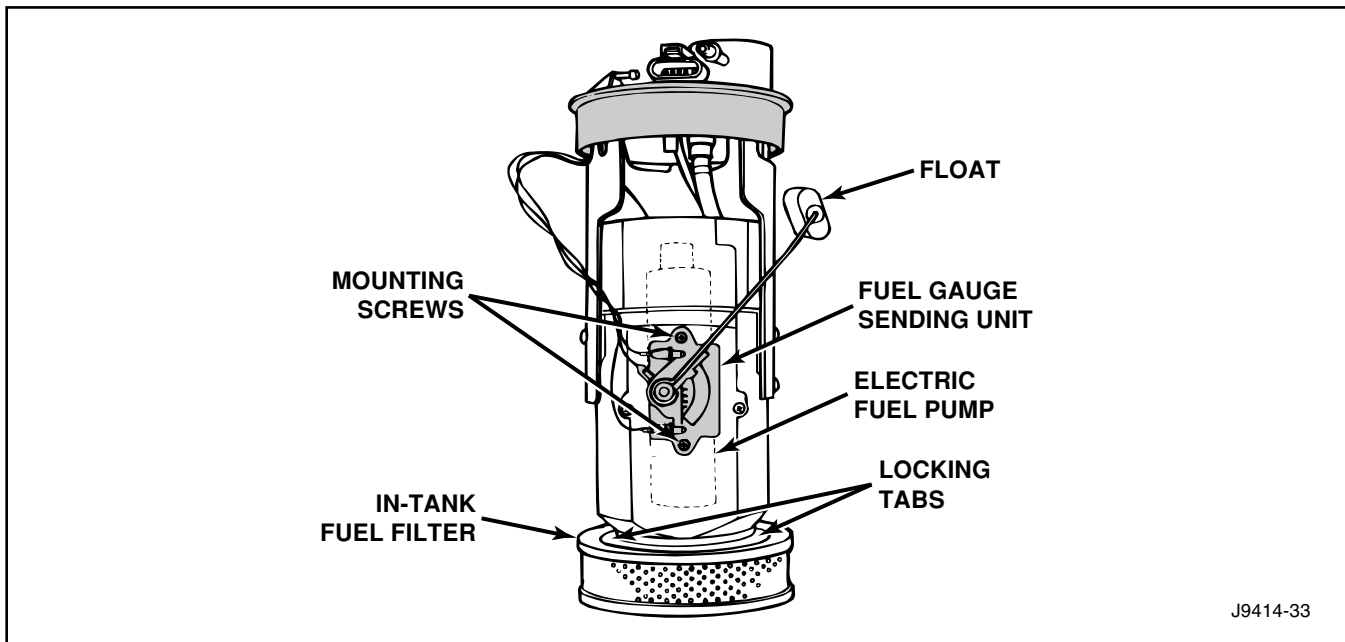

Figure 5 1996 BR Fuel Pump Module

## 8.0L - V10 Fuel Injection

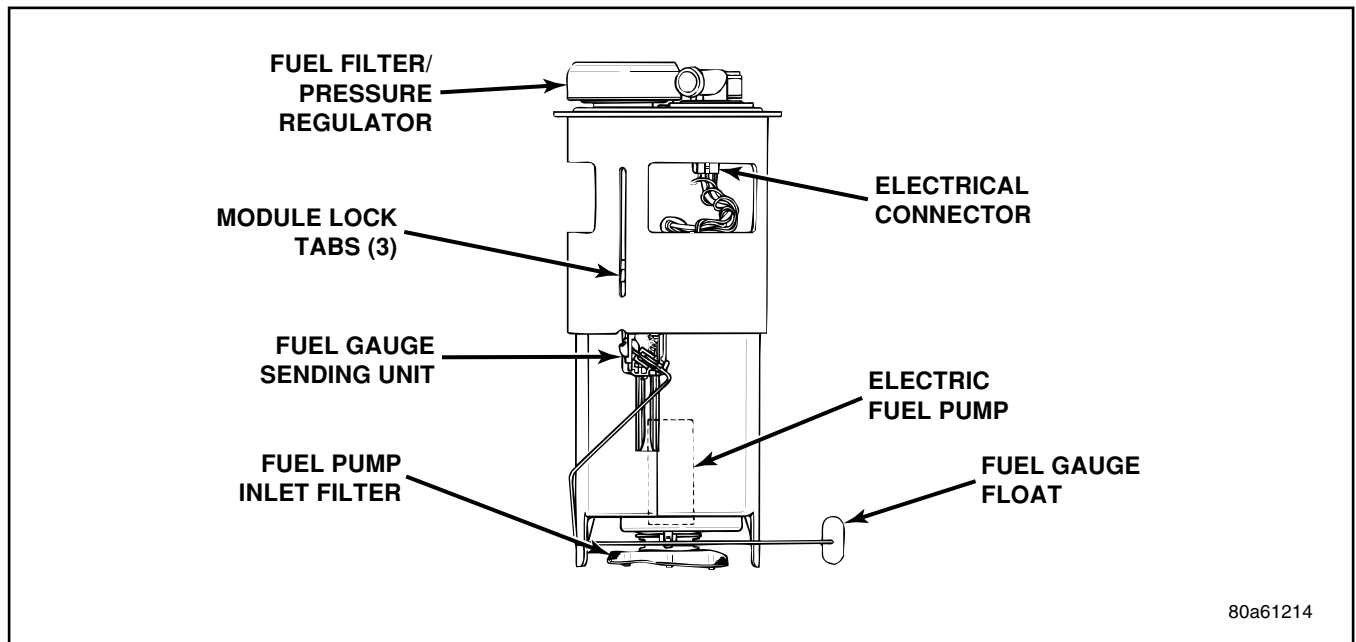

Figure 6 Typical 1997 BR Fuel Pump Module

The pump draws fuel through a strainer and pushes it through the motor to the outlet. The pump contains two check valves. One valve relieves internal fuel pump pressure and regulates maximum pump output. The second valve, in the pump outlet, maintains pump pressure during engine-off conditions.

### CHECK VALVE OPERATION

The electric fuel-pump outlet contains a one-way check valve to prevent fuel flow back into the tank and to maintain fuel supply-line pressure (engine warm) when the pump is not operational. It is also used to keep the fuel supply line full of gasoline when the pump is not operating. After the vehicle has cooled down, fuel pressure may drop to 0 psi (cold fluid contracts), but liquid gasoline will remain in the fuel supply line between the check valve and the fuel injectors. **Fuel pressure that has dropped to 0 psi on a cooled-down vehicle (engine off) is a normal condition.** When the electric fuel pump is activated, fuel pressure should **immediately** rise to specification.

The fuel systems use a positive displacement, gerotor, immersible pump with a permanent magnet electric motor (fig. 3). Also, see Figures 4 and 5 for other fuel pump modules.

This fuel system does not contain the traditional fuel return lines. The regulator contains a calibrated spring, which forces a diaphragm against the fuel filter return port. When pressure exceeds the calibrated amount, the diaphragm retracts, allowing excess pressure and fuel to vent into the tank.



## 8.0L – V10 Fuel Injection

If the fuel delivery system becomes blocked between the fuel pump and the regulator, the maximum deadhead pressure of the pump is approximately 880 kPa (130 psi). The regulator adjusts fuel system pressure to approximately 338 kPa (49 ± 5 psi) for the BR, and 379 kPa (55 ± 5 psi) for the SR.

A fuel gauge level sending unit is attached to the fuel pump module. The fuel level input is used as an input for OBD II. Fuel level below 15% or above 85%, on LDP-equipped vehicles, of total tank capacity disables several monitors. There are diagnostics for the fuel level circuit open and shorted (Table 1).

<b>Diagnostic</b>	<b>DTC</b>	<b>MIL</b>
OBD II Major Monitors	Disabled	Disabled
Front O2S Voltage Checks	Active	Active
Rear O2S Voltage Checks faults	Active	Active
Front/Rear O2 Heater	Active	Active
VSS Rationality	Active	Active
P/N Switch Rationality	Disabled	Disabled

Table 1 Fuel Level Diagnostics

**WARNING:** *Be very careful when removing the fuel pump module from the fuel tank as gasoline remaining in the module reservoir will spill.*

# 8.0L – V10 Fuel Injection

## FUEL PRESSURE REGULATOR

All Dodge truck and Viper vehicles use a returnless fuel system. On a return system, all fuel is routed through the hot environment of the engine compartment. Without a return line, the fuel remains in the tank and is cooler. This reduces evaporative emissions, resulting in less evaporative canister purging.

Returnless fuel systems do not have a return line routed from the fuel rail to the fuel tank. The pressure regulator is part of the fuel pump module (fig. 6). It is part of a filter/regulator assembly on some vehicles and a separate piece on others.

The pressure regulator is a mechanical device that is not controlled by the PCM. The regulator contains a calibrated spring and a diaphragm that actuates the regulator valve. Fuel pressure operates on one side of the diaphragm, while spring pressure operates on the other side. The diaphragm opens the valve to the return port, allowing fuel to be dumped back into the fuel tank. System fuel pressure reflects the amount of fuel pressure required to open the port. The spring on the opposite side of the diaphragm attempts to close the valve, causing an increase of pressure on the fuel as it travels to the fuel rail. The spring is not adjustable. On the SR, the spring is calibrated to maintain approximately 379 kPa ( $55 \pm 5$  psi) of fuel pressure. On the BR, the spring maintains 338 kPa ( $49 \pm 5$  psi).

In the past, the regulator was mounted on the fuel rail so that as the manifold vacuum at the tip of the injector changed, fuel pressure was modified to maintain a constant injector flow volume. With the regulator mounted at the tank, a constant fuel pressure is always supplied to the injectors. The PCM uses a special formula using MAP information that calculates the pressure differential across the injector, and then adjusts injector pulse width.

## Fuel Flow

Depending upon the vehicle, the fuel flow is as follows:

### SR

**Remote-mounted filter (two hoses)** — Fuel flows from the pump to the regulator mounted on top of the module. From the regulator, it flows to the filter, mounted to the frame, and then to the fuel rail. The regulator on the pump module maintains  $55 \pm 5$  psi in the filter and lines.

### BR

**Integral filter** — Fuel flows from the pump, through the combination regulator filter, to the fuel rail. Fuel pressure is maintained at  $49 \pm 5$  psi.

# 8.0L - V10 Fuel Injection

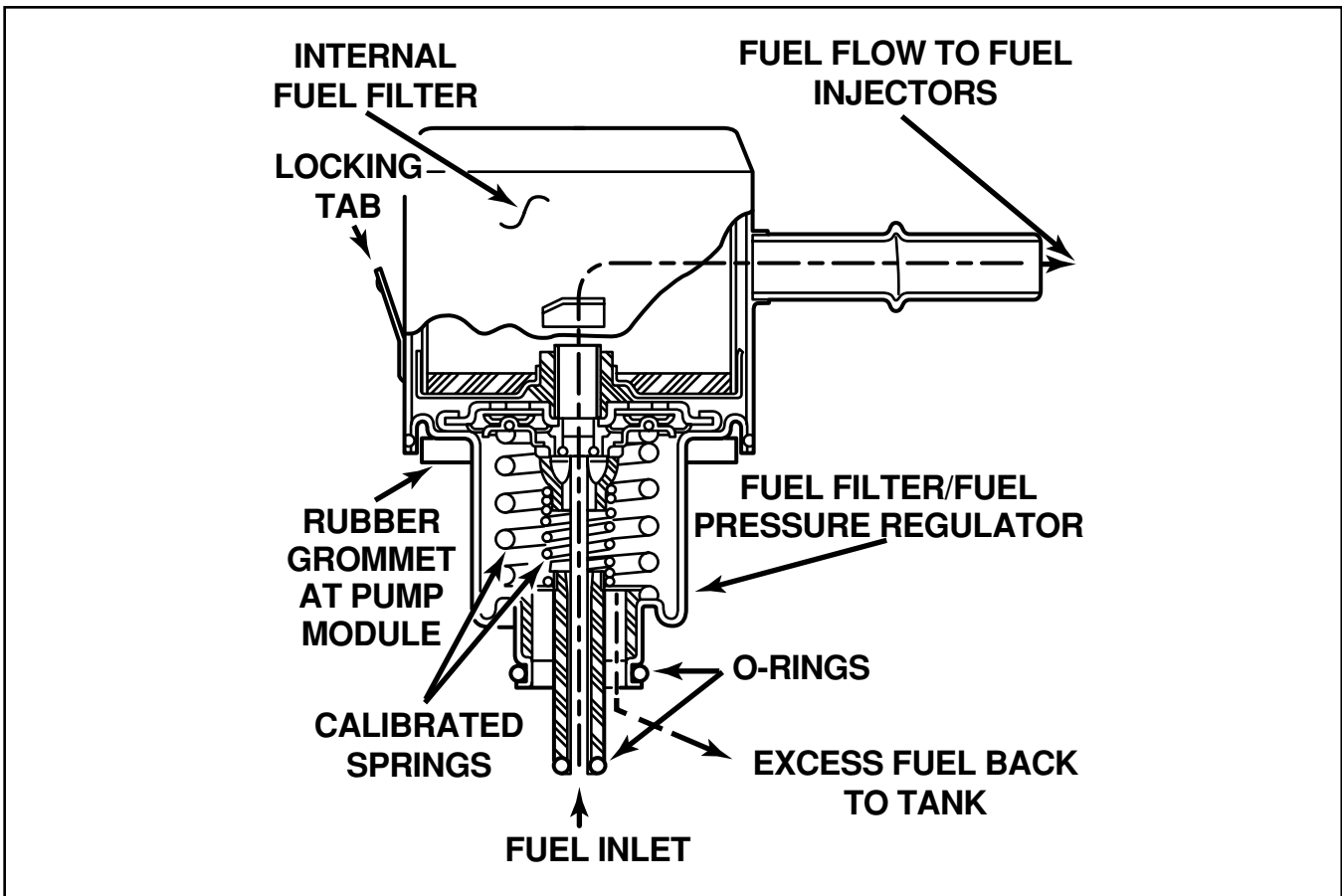

Figure 7 Typical 1996 and 1997, Side View, Filter/Regulator

# 8.0L - V10 Fuel Injection

## FUEL PUMP RELAY

The fuel pump relay is located inside the Power Distribution Center (PDC) on the BR. For the SR, the relay is located in the trunk. It is energized to provide power to operate the fuel pump under the following conditions:

- For approximately 1.8 seconds during the initial key-on cycle.
- While the CKP sensor is providing an RPM signal that exceeds a predetermined value.

Ignition voltage is provided to the fuel-pump relay coil anytime the key is in the RUN/START position (fig. 8). The PCM provides the ground control to energize the relay. Unlike previous Chrysler systems (non-OBD II), the fuel pump relay does not provide power to operate the O2 Sensor heater.

The relay is energized when the key is cycled to RUN to prime the fuel rail with liquid fuel, allowing for a quick start-up. Anytime the CKP sensor indicates that an RPM signal exceeds a predetermined value, the relay is energized to ensure proper fuel pressure and volume during engine cranking and running conditions. Anytime the CKP sensor signal is lost (engine has been shut off or the sensor indicates no rpm), the fuel pump relay is de-energized.

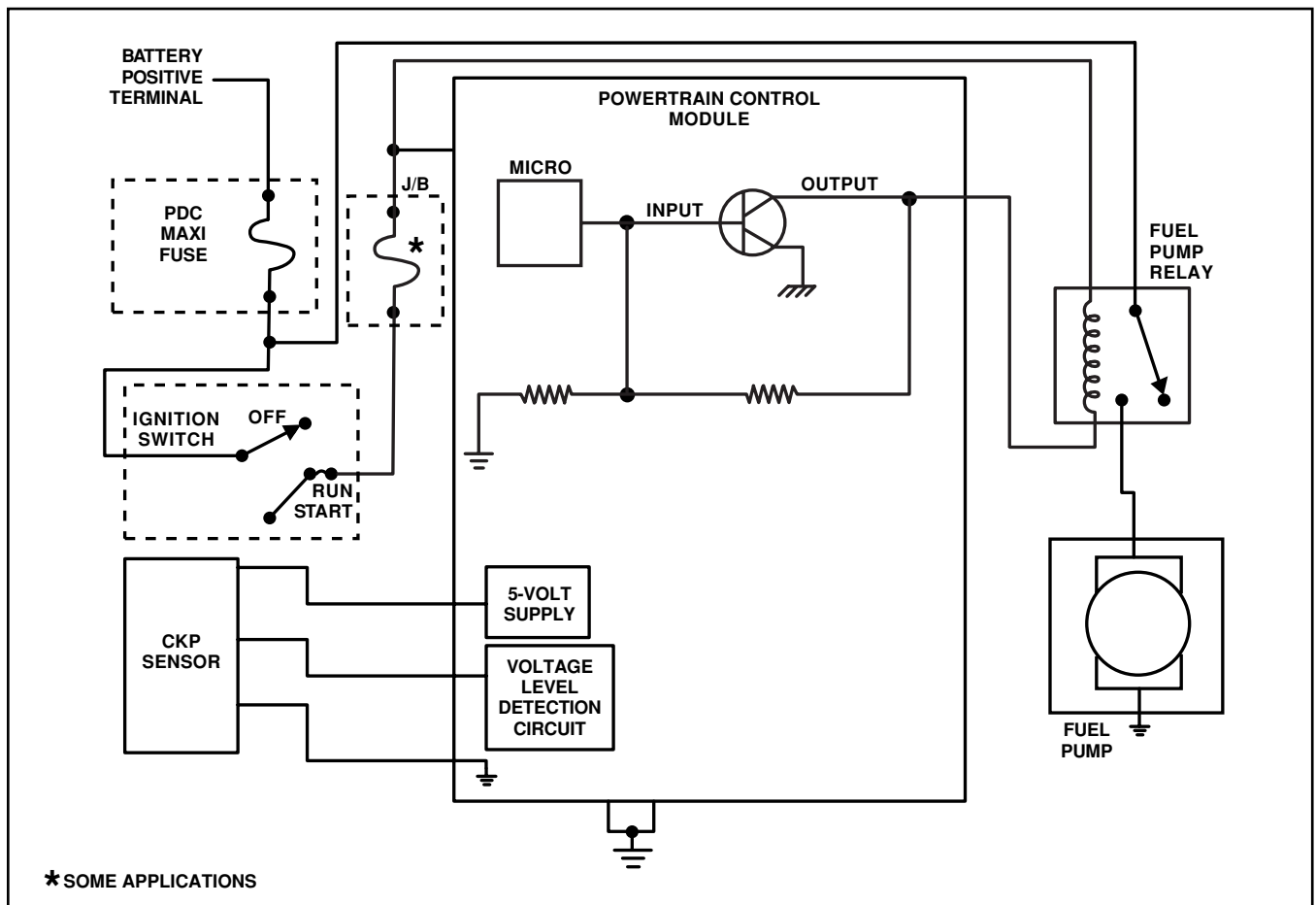

Figure 8 Fuel Pump Relay Circuit

# 8.0L – V10 Fuel Injection

## FUEL INJECTORS

***WARNING: Release fuel system pressure before servicing fuel system components. The procedure is described in the Service Manual. Service vehicles and fuel system components in well-ventilated areas. Avoid sparks, flames and other ignition sources. Never smoke while servicing the vehicle's fuel system.***

The BR V10 engines use top-feed fuel injectors mounted to the fuel rail with push-on retaining clips. O-rings prevent leakage between the injectors and the fuel rail.

The SR engines use bottom feed injectors that are supplied fuel from a rail that is part of the intake manifold.

The fuel injectors are 12-ohm electrical solenoids. Each injector contains a needle valve that closes off an orifice at the nozzle end. When electrical current is supplied to the injector, the armature and needle move a short distance against a spring, allowing fuel to flow out the orifice. Because the fuel is under high pressure, a fine spray is developed in the shape of a hollow cone. The spraying action atomizes the fuel, adding it to the air entering the combustion chamber (fig. 9).

***CAUTION: If an injector must be removed on a Viper for inspection or service, you must purge the fuel rail of all fuel. Otherwise, flooding of one cylinder with fuel may occur. Consult the Fuel Injection section of the appropriate Service Manual for proper service procedures.***

The fuel injectors are positioned in the intake manifold with the nozzle ends directly above the intake valve port for the corresponding cylinder.

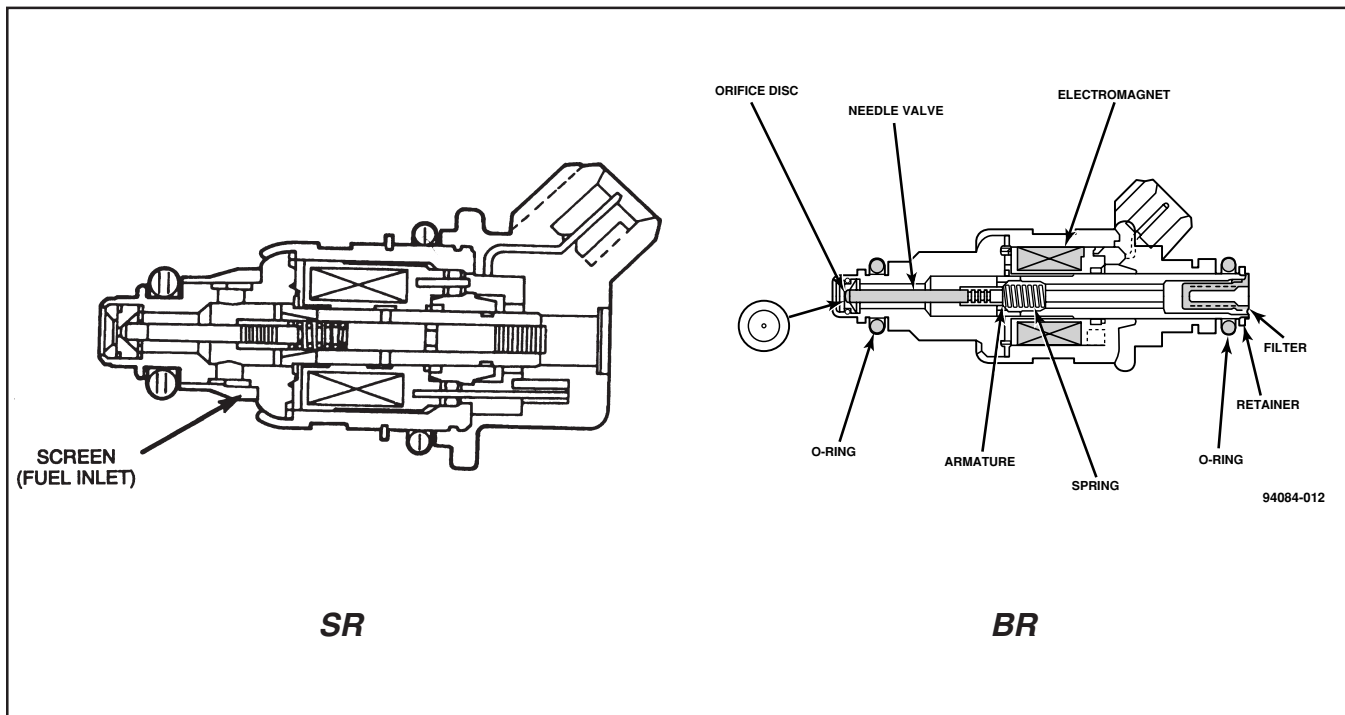

Figure 9 Fuel Injector

## 8.0L – V10 Fuel Injection

Fuel is dispersed through one opening at the bottom of each injector (fig. 9). This design allows for an atomized spray, similar to that of a pintle injector, but with the low cost and easy serviceability of a pencil-stream injector.

### FUEL FILTER

There are two different types of fuel filters. One is integral with the fuel pressure regulator (BR) and attaches to the fuel pump module. The other is mounted just outside the tank (SR). The remote filter has two lines attached to it. Both filters are life-of-the-vehicle items. Replacement is necessary, only if something has caused the filter to become plugged, such as contaminants in the fuel. Regular maintenance is no longer required because only the fuel actually being used by the engine is filtered.

**NOTE:** *Always lubricate the O-rings inside the quick-connect fittings with engine oil, before reassembling the fuel line connections at the fuel pump module, fuel filter fuel lines and the fuel rail.*

### FUEL LINES AND RAIL

#### Fuel Lines

The high-pressure line from the tank to the filter or engine is a combination of rubber, plastic and steel lines. The hose clamps used to secure rubber hose sections have a special rolled edge construction to prevent the edge of the clamp from cutting into the hose.

**NOTE:** *If the O-rings at the quick-connect fittings become damaged, the line must be replaced.*

# 8.0L – V10 Fuel Injection

## Fuel Rail

The fuel rail is used to supply fuel to the injectors for the BR, the fuel rail is mounted on the intake manifold (fig. 10). For the Viper, the fuel rail is an integral part of the intake manifold. Both attach to the fuel line with a quick connect fitting. If the o-rings at the quick connect fittings become damaged, the line must be replaced.

A fuel pressure test port is provided on some applications. On the Viper, there is a test port located on the Intake Manifold Right Bank between Injectors #9 and #10.

On the Ram Pickup, the test port is on the fuel rail at the passenger side, front corner of the engine.

Always follow the procedures in the Service Manual when removing fuel system components.

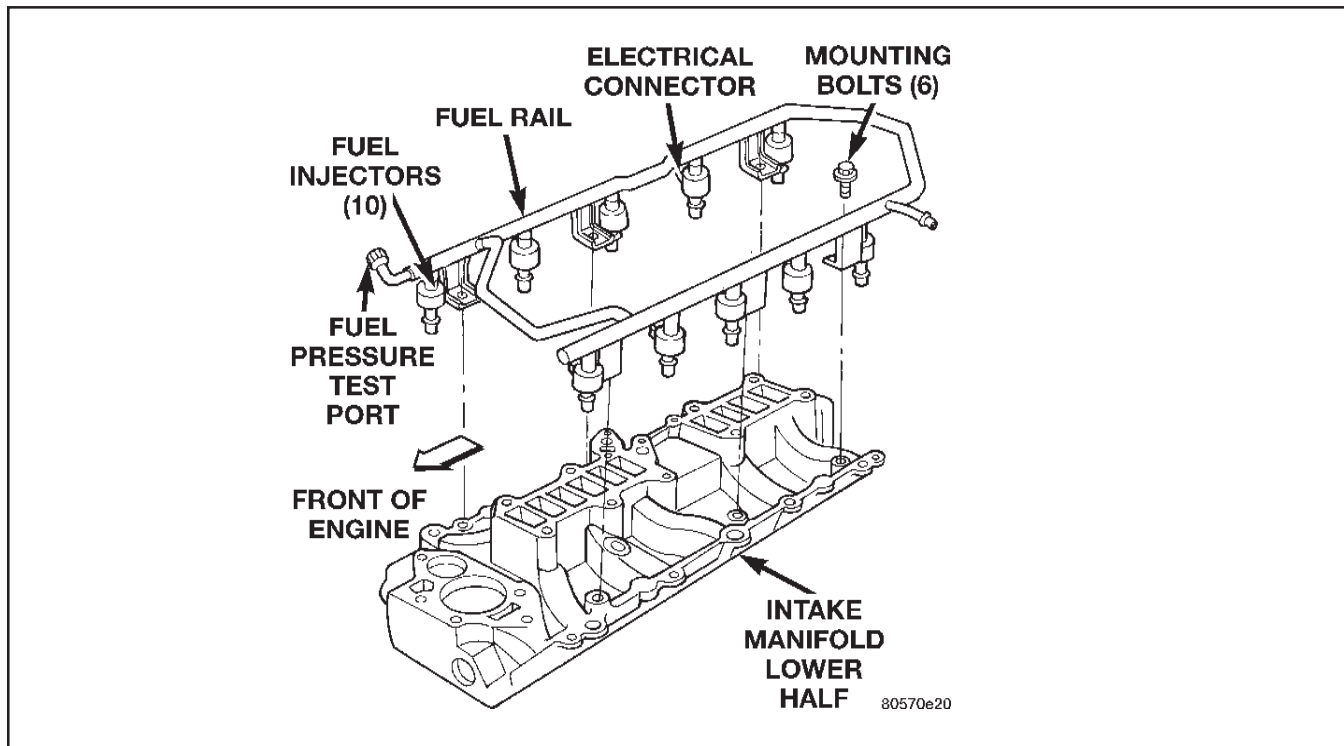

Figure 10 V10 Fuel Rail (BR)

**WARNING:** *The clips used to hold the injectors to the fuel rail on RAM Trucks are for assembly only. The clips are not designed to hold the injectors on with 49 psi of fuel pressure.*

# 8.0L - V10 Fuel Injection

## THROTTLE BODY

The throttle body mounts to the intake manifold. These models use a contoured throttle body (figs. 11 and 12). The BR uses a single two-barrel throttle body. The SR uses two single throttle bodies.

The contoured throttle body changes air velocity slightly with moderate pedal movement. The first 1/3 of opening takes a lot of throttle movement, then opening occurs much faster. This helps reduce buck and bobble at light throttle positions.

The BR Throttle Position Sensor (TPS) and Idle Air Control (IAC) motor are attached to the throttle body. On the Viper, the TPS is attached to the throttle body, however the IAC is located in a separate air distribution hose.

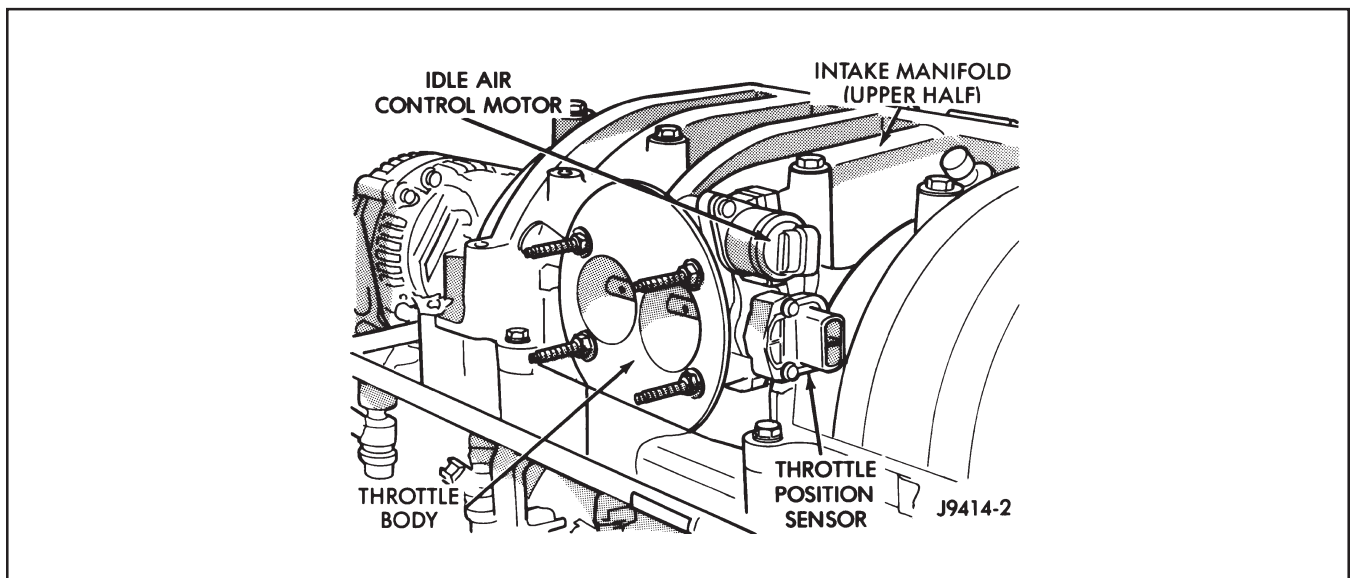

Figure 11 Throttle Body - BR

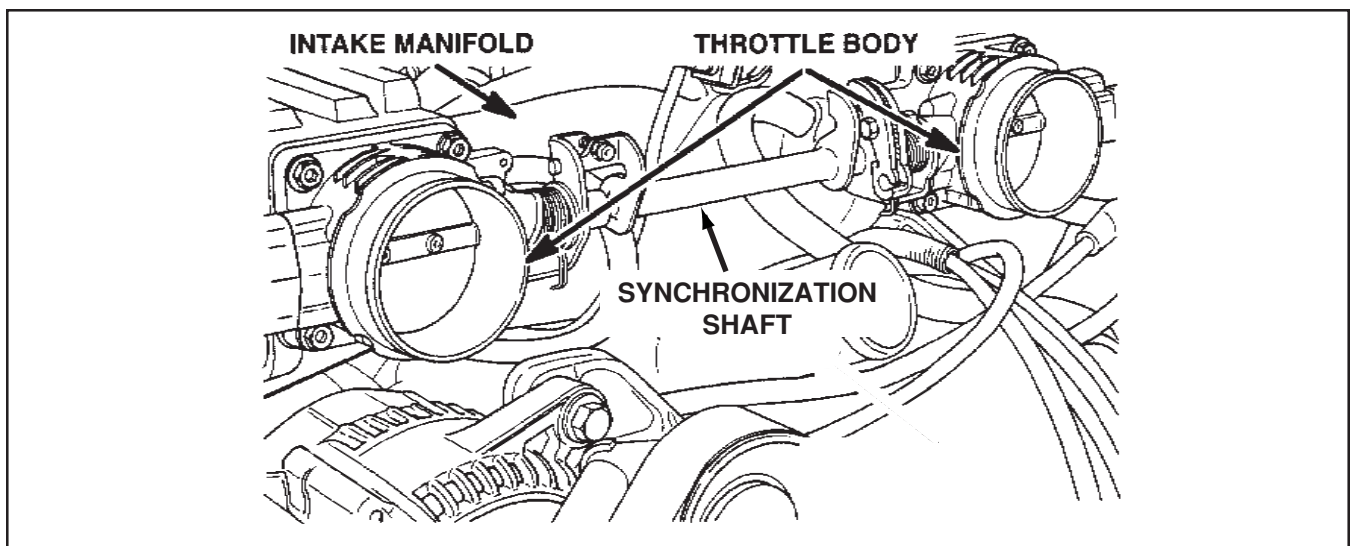

Figure 12 Viper Throttle Body - '96 Coupe/'97 All



# 8.0L – V10 Fuel Injection

## ACTIVITY 1 – FUEL SYSTEM TEST

### Instructions

Have the instructor assign you to a vehicle equipped with a V10 engine. Use the Service Manual and DRB III to assist in answering the following questions:

1. In which section of the Service Manual will you find the fuel system test procedures? \_\_\_\_\_
2. According to the Service Manual, what is the fuel pressure specification for the 8.0L BR? \_\_\_\_\_ 8.0L Viper? \_\_\_\_\_
3. The following questions pertain to releasing the fuel system pressure.  
What could happen if the gas cap is not removed from the fuel tank before starting this procedure? \_\_\_\_\_  
The procedure in the Service Manual identifies the first step in releasing fuel system pressure as “removing the fuel pump relay.” Where is relay located on the assigned vehicle? \_\_\_\_\_
4. List the appropriate tools required to depressurize and test the fuel system.  
\_\_\_\_\_  
\_\_\_\_\_
5. Following the procedure listed in the Service Manual, depressurize the fuel system on the assigned vehicle and connect the appropriate tools. Using the DRB III, access the Actuator Test for Fuel System Test. Perform the fuel pressure test. What is the fuel system pressure of the vehicle? \_\_\_\_\_  
What is the DRB III doing to accomplish this test? \_\_\_\_\_

After completing this task, return the vehicle to its original state.



# 8.0L – V10 Fuel Injection

## LESSON 3

### POWERTRAIN CONTROL MODULE

#### POWER SUPPLIES AND GROUNDS

In order to function, the PCM must be supplied with battery voltage and a ground (fig. 15). The PCM monitors battery voltage during engine operation. If the voltage level falls, the PCM increases the initial injector opening point to compensate for low voltage at the injector. Low voltage causes a decrease in current flow through the injector and can prevent the injector plunger from fully opening in the allotted time, resulting in decreased fuel flow.

Battery charging rate is controlled by the PCM, except for the 96 Roadster. The target charging rate voltage is based upon inputs from Battery Temperature Sensor (BTS). The BTS is located in the bottom of the battery tray.

The PCM must be able to store diagnostic information. This information is stored in a battery-backed RAM. Once a DTC is read by the technician, the technician can clear the RAM by disconnecting the battery for approximately 60 seconds, or using the DRB III scan tool.

The PCM has two power inputs: direct 12 volts and switched ignition 12 volts. Battery voltage is supplied to the PCM to power the 5-volt power supply and allow the PCM to perform fuel, ignition and emission control functions. The PCM monitors this direct battery-feed input to determine charging rate, control the injector initial opening point, and back up the RAM used to store the DTC functions. This is called sensed battery and will be discussed later.

When the ignition switch is turned ON, the 12-volt input acts as a "wake up" signal to an integrated circuit that then turns on the power supply.

The power supply output of 5 volts supplies multiple locations within the controller and is also used as the reference voltage for sensor operation. Some of the locations within the controller that use 5 volts are all of the microprocessors. Another output of the 5-volt power supply is a line that is split to make the primary and secondary 5-volt outputs; pins A17 and B31 respectively.

The primary output is used as a reference voltage for the TPS and MAP sensor as well as a power supply to operate the CMP and CKP sensors. The secondary output is used as a reference voltage for the transmission governor pressure transducer when equipped with an RE transmission. It is also used as a power supply for the VSS.

## 8.0L - V10 Fuel Injection

Another use of the power supply is a reference voltage for the internal use of the PCM. The microprocessors determine current sensor state by comparing the sensor signal to the reference voltage. The difference between the two voltages equals the sensor state.

The PCM has two grounds, both are identified as power grounds. All the high current, noisy devices are connected to these grounds as well as all the sensor returns. The sensor return comes in, passes through noise suppression and is then connected to the power ground.

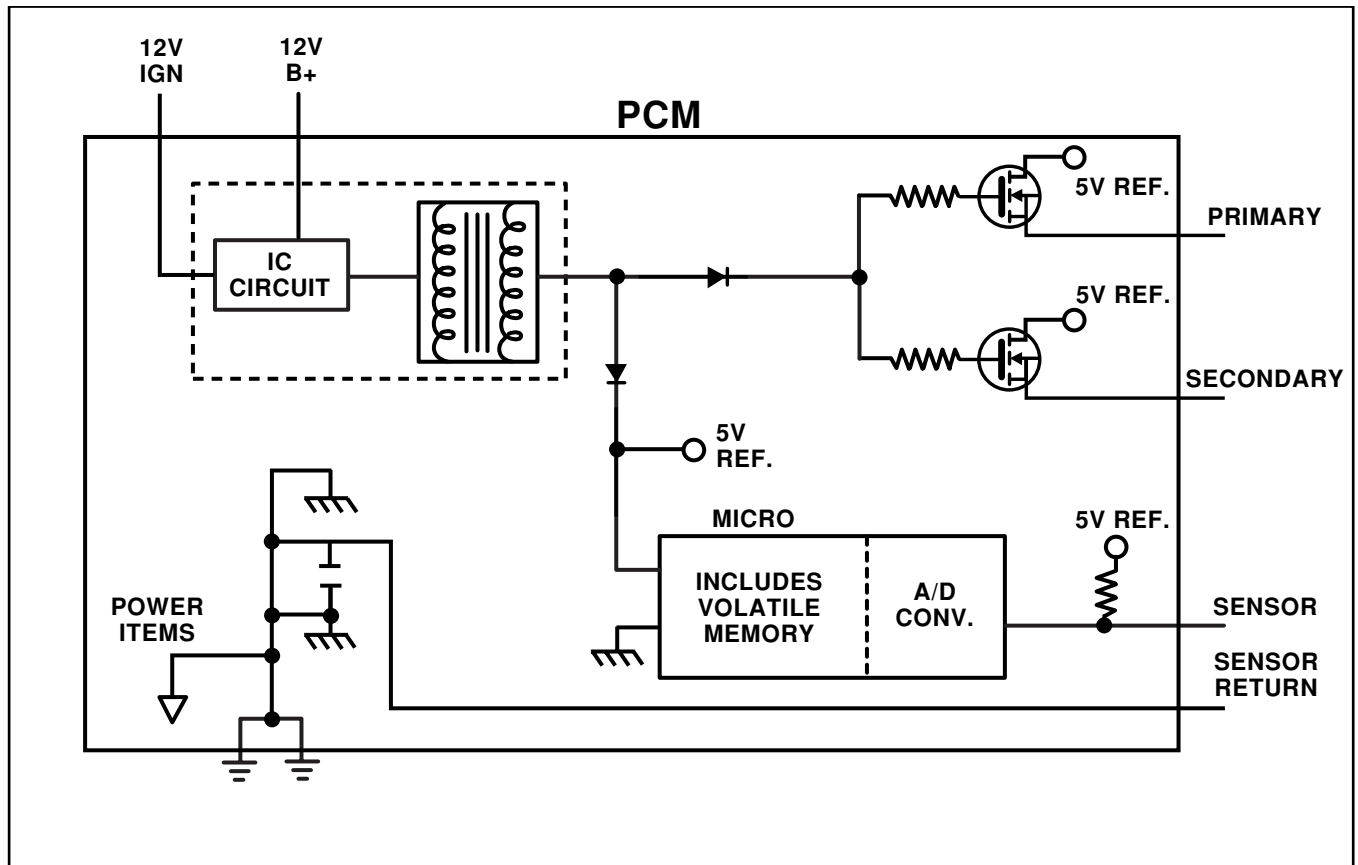

Figure 13 Power Supplies and Grounds

# 8.0L – V10 Fuel Injection

## CCD Bused Messages

In 1996 and 1997, the only 8.0L that used the data bus called the “Chrysler Collision Detection” (CCD) system (figs. 14) was the Viper Coupe and the Roadster. However, in 1998, all Dodge trucks that use the 8.0L engine use the CCD system. The 1996 and 1997 Viper products are using the CCD bus to pass information collected by the PCM to the Security Alarm Module and the Entry Module. This eliminates the need for both the PCM and the various modules to receive the same inputs. In 1998, Dodge Truck products will use the CCD Bus to pass information collected by the PCM to the instrument cluster. This eliminates the need for both the PCM and the instrument cluster to receive the same inputs. The following is a list of inputs and outputs that are communicated across the CCD bus:

- Engine RPM
- Fuel level
- Oil pressure
- Vehicle speed
- Coolant temperature
- Voltage
- Transmission temperature
- Engine model
- Upshift lamp
- Vehicle Identification Number (VIN)
- Speed control enable
- Check Engine light operation
- Check gauges light operation

The PCM also uses information, such as fuel level. This input is used by the PCM Task Manager for On Board Diagnostics II, or OBD II. If a vehicle is equipped with Theft Alarm, an “OK to start” message is bused from the security alarm module to the PCM.

The PCM also delivers fault code information to the instrument cluster. This information is used for MIL illumination and DTC retrieval.

## Data Link Connector

The PCM maintains communication with scan tools through the vehicle’s Data Link Connector (DLC). The DLC connectors are located under the instrument panel, to the left of the steering column bracket.

# 8.0L - V10 Fuel Injection

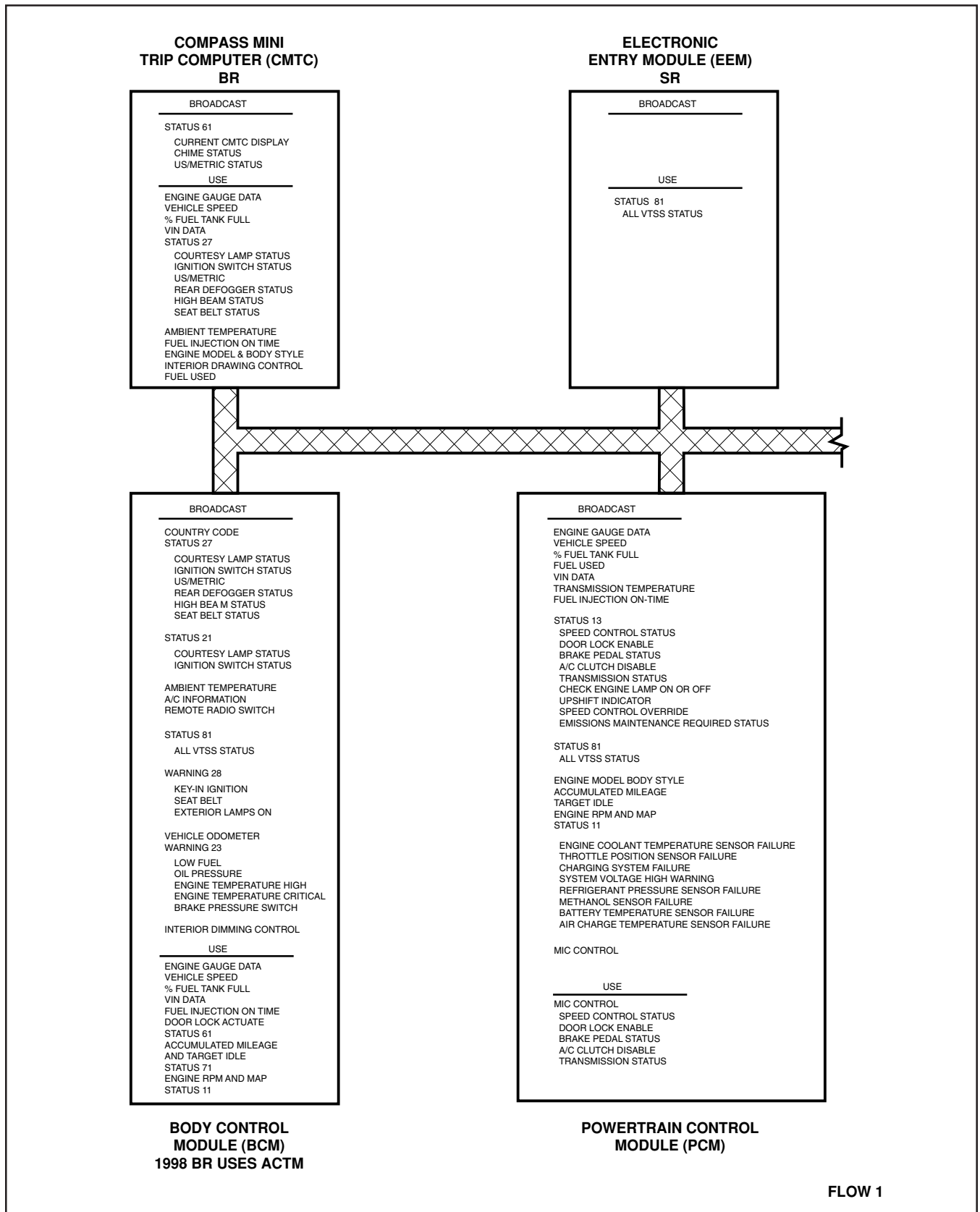

Figure 14a CCD System

# 8.0L – V10 Fuel Injection

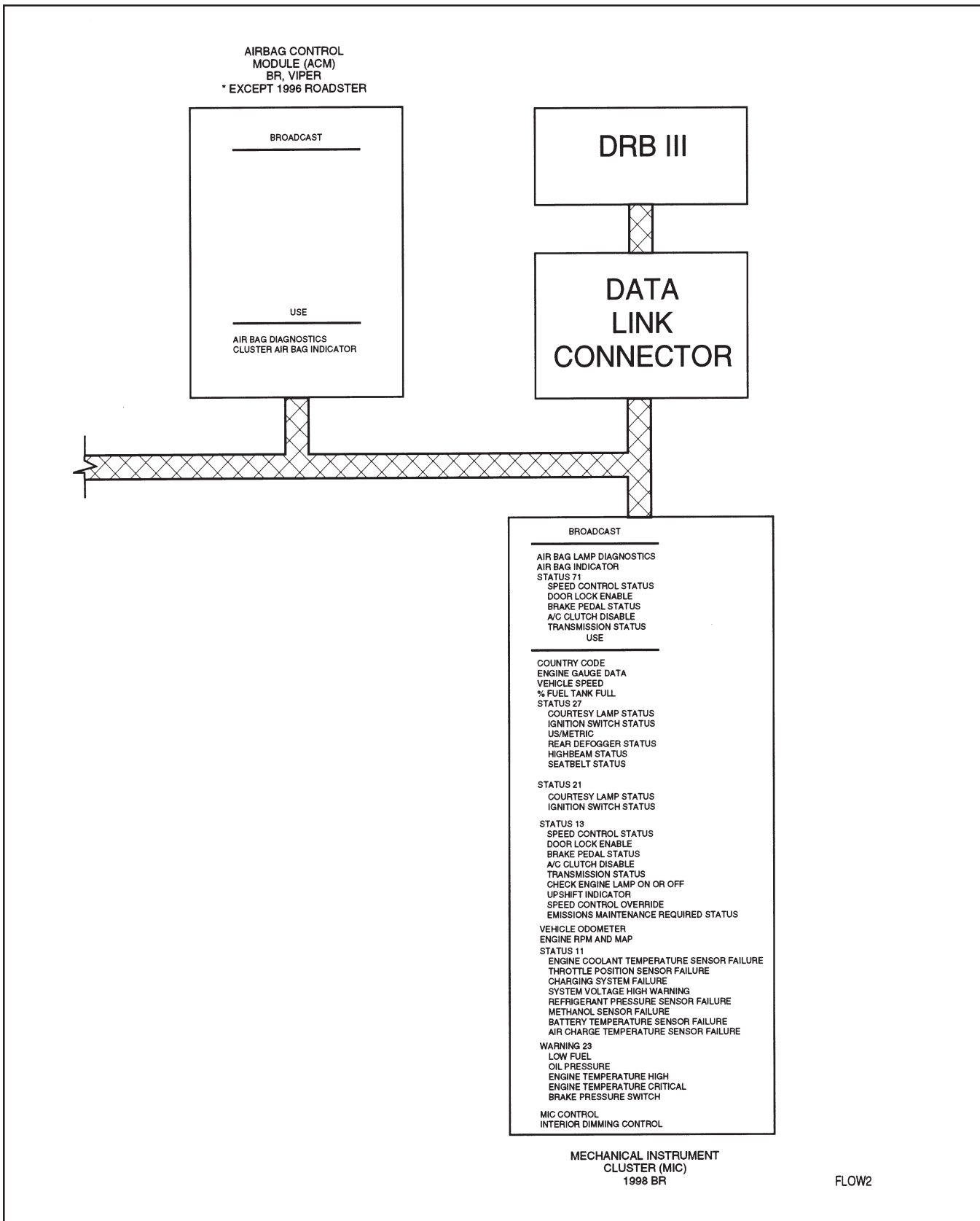

Figure 14b CCD System

# 8.0L – V10 Fuel Injection

## ACTIVITY 2 – PCM POWER AND GROUNDS

### Instructions

Have the instructor assign you to a vehicle equipped with a V10 engine. Use the Service Manual and the Powertrain Diagnostic Procedures manual to assist in answering the following questions.

1. Can the PCM connectors be interchanged? \_\_\_\_\_
2. Are the PCM connectors numbered? \_\_\_\_\_
3. Using the Driveability book, what are the pins for power? \_\_\_\_\_
4. Using a voltmeter, and with key off, what is sensed battery ignition? \_\_\_\_\_
5. Turn the key on. What is sensed battery voltage? \_\_\_\_\_
6. Reverse the leads on the voltmeter. Identify the ground pins and probe them for voltage. What are the voltage readings? \_\_\_\_\_
7. Hook up DRB III to engine. What does the learned vehicle configuration show?



# 8.0L – V10 Fuel Injection

## LESSON 4

### FUEL INJECTION SYSTEM — PCM INPUTS

#### CRANKSHAFT POSITION SENSOR

The Crankshaft Position Sensor (CKP) is mounted in the passenger side of the engine block, below the exhaust manifold. The CKP is a Hall-effect type sensor that is used to provide input to the PCM regarding the exact position of the crankshaft and pistons. This type of sensor detects slots cut into a pulse ring machined into the middle of the crankshaft (fig. 15). The CKP signal alone is used to determine engine RPM. When combined with input from the Camshaft Position Sensor (CMP – discussed later), CKP input is used to determine:

- Top Dead Center (TDC)
- Ignition Timing
- Injector Synchronization

The engine will not start if the PCM does not receive the CKP signal.

The pulse ring has five groups of two notches equally spaced at its outer edge (fig. 15). Each group of notches represents a signal for a specific set of pistons. The PCM determines basic timing by the position of the falling edge of the slots. Each corresponding slot is  $72^\circ$  apart and is  $3^\circ$  wide. There are  $15^\circ$  between each slot in the pair. The falling edge of the first slot of each pair of slots is used for cylinders 10, 4, 6, 8 and 2 (fig. 15) and the second falling edge is used for cylinders 1, 9, 3, 5 and 7. It may take the PCM one full engine revolution to determine crankshaft position while cranking.

The V10 is a  $90^\circ$  block. This means that the combined angle of the bore center lines of the opposing banks are  $90^\circ$  and that a piston comes up to TDC every 90 degrees. With 10 cylinders, each one would be fired in  $900^\circ$  of crankshaft rotation ( $10 \times 90 = 900$ ). To match cylinder firing with crankshaft rotation, it was necessary to make an “odd fire” engine. This means that all the cylinders are not fired at the same amount of crankshaft rotation. Five cylinders are fired at  $54^\circ$  and the other five are fired at  $90^\circ$  of crankshaft rotation. All of these angles added together total  $720^\circ$  or two complete crankshaft revolutions. Because of the odd firing, it is necessary to use different notch edges to properly stagger the spark.

# 8.0L - V10 Fuel Injection

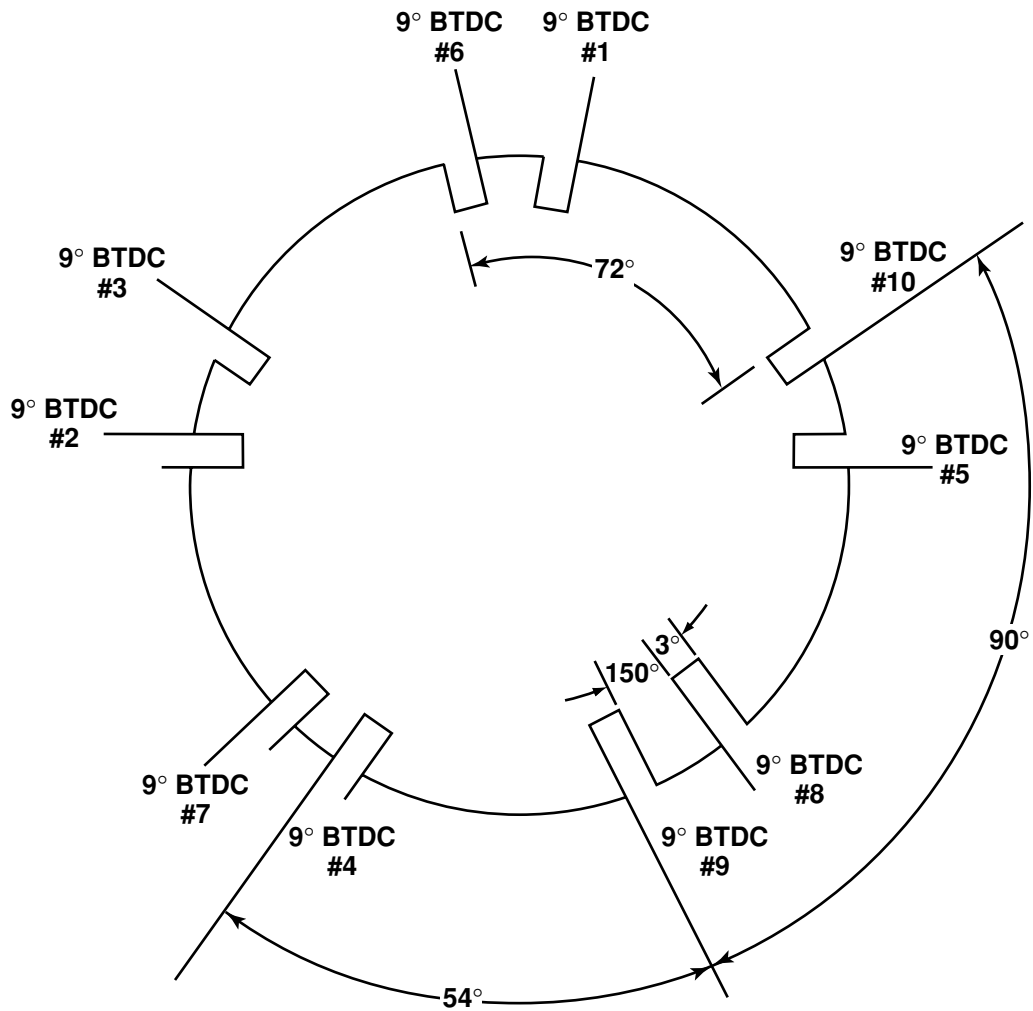

FIRING ORDER: 1-10-9-4-3-6-5-8-7-2

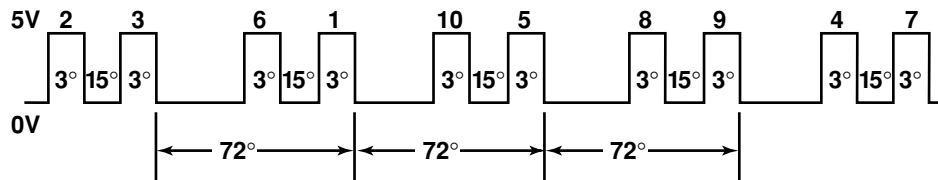

Figure 15 Crankshaft Pulse Ring

## 8.0L - V10 Fuel Injection

The PCM supplies 5 volts to the sensor for operation of the Hall-effect chip and other sensor electronics (Fig. 16). The PCM also provides a ground for the sensor on the sensor return circuit. Finally, the PCM provides a 5 volt reference signal to the CKP through a third circuit. This reference voltage alternates between 5 volts and 0 volts with the rotation of the crankshaft.

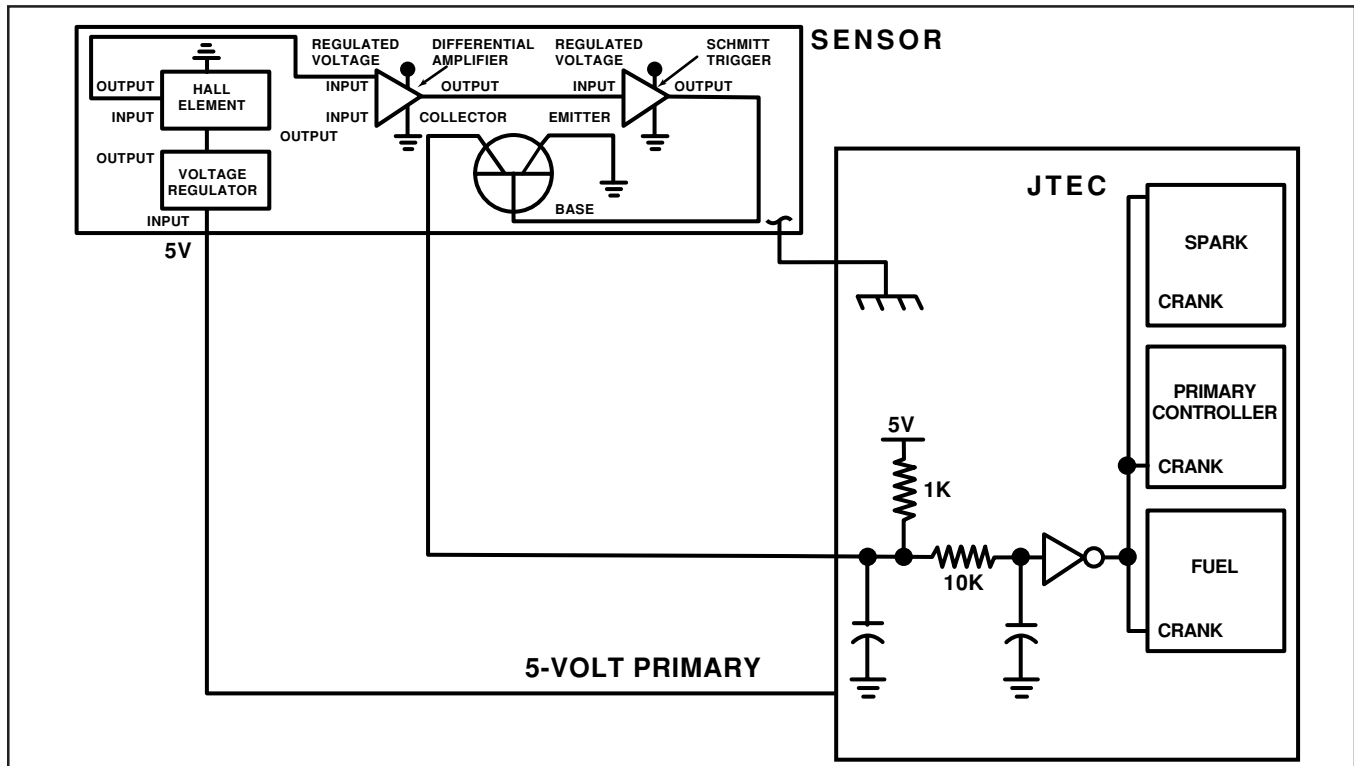

Figure 16 Crankshaft Position Sensor Circuit

The Hall effect switch contains a magnet. As the magnetic field passes over a notch in the pulse ring, the 5 volt signal is pulled to ground through a transistor in the sensor. When a solid portion of the ring is in front of the sensor, the transistor is turned off and the reference voltage returns to 5 volts. The PCM identifies crankshaft position by registering the cycles from 0 to 5 volts. A typical CKP signal is shown in Figure 15.

## 8.0L – V10 Fuel Injection

### Crankshaft Position Sensor Service

The sensor's powerful magnet is susceptible to damage. Do not drop the sensor on a metal table, or store sensors face-to-face. The clearance between the sensor and the counterweight is not adjustable. Though the clearance is critical, manufacturing tolerances allow for some differences in clearance.

**In order for the vehicle to start, both the cam and crankshaft position sensor signals must be present. On eight-digit part number PCMs, both the cam and crankshaft position sensor signals are necessary for continued operation.**

**On 10-digit part number PCMs (1997), once the engine is running, the cam sensor signal is not needed for continued operation.**

***CAUTION: The Viper crankshaft position sensor has a foil heat shield attached by the CKP mounting bolt covering the sensor. The heat shield must be properly installed to ensure that the CKP sensor remains protected from the heat of the exhaust system.***

# 8.0L - V10 Fuel Injection

## CAMSHAFT POSITION SENSOR (CMP)

The Camshaft Position Sensor (CMP) functions similarly to the CKP. The CMP is also a Hall-effect sensor that provides input to the PCM regarding crankshaft position and cylinder identification. The PCM uses the CMP input along with the CKP input to determine exact piston location and determines spark/fuel delivery.

The CMP sensor is mounted in the front of the timing case cover (fig. 18). The camshaft sprocket has a metallic step that passes in front of the CMP sensor (fig. 18). The PCM is able to identify piston location by monitoring the position of this step.

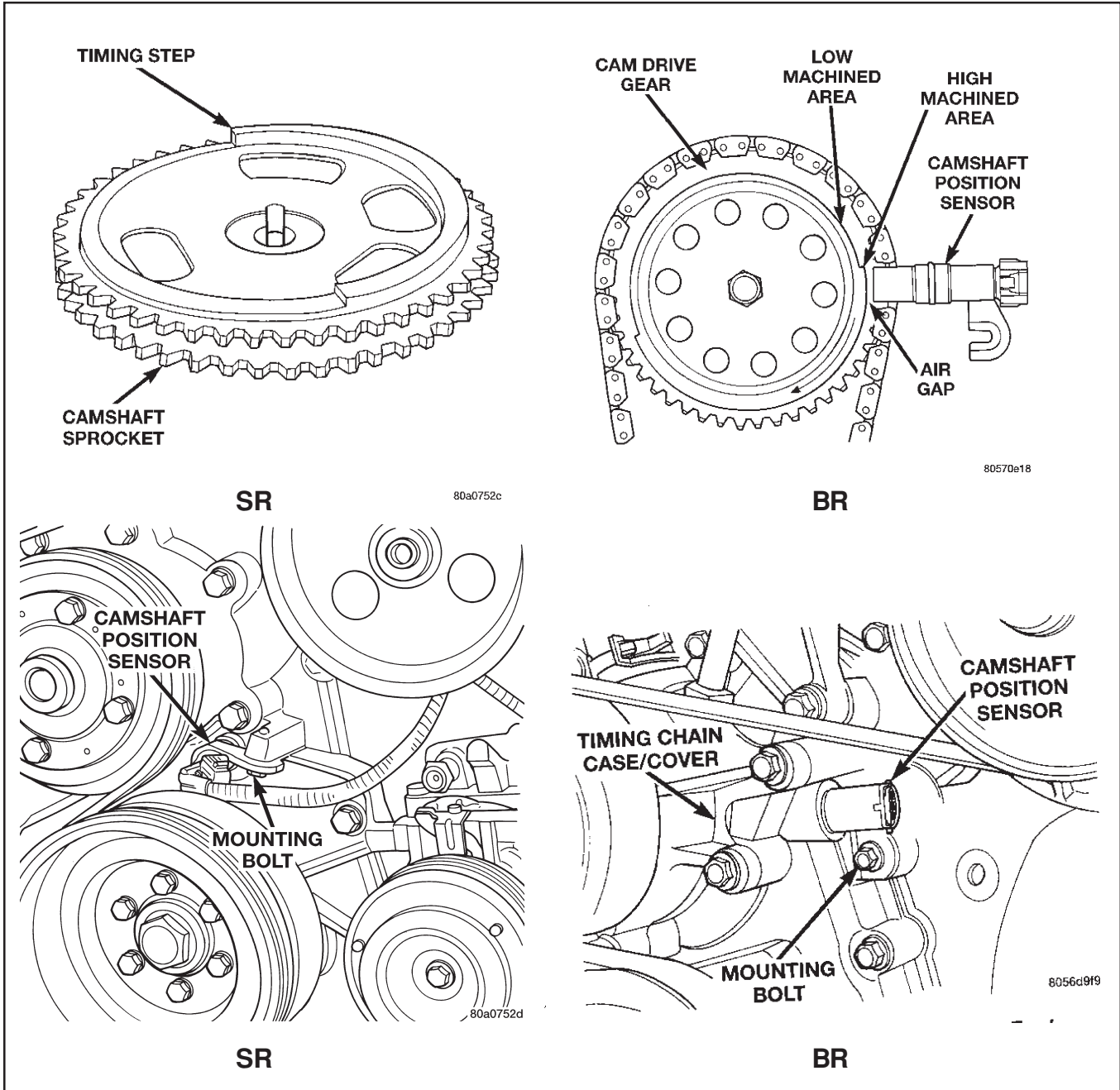

# 8.0L - V10 Fuel Injection

The PCM supplies 5 volts to the sensor for operation of the Hall-effect chip and other sensor electronics (fig. 19). The PCM also provides a ground for the sensor on the sensor return circuit. This reference voltage alternates between 5 volts and 0 volts with the rotation of the camshaft.

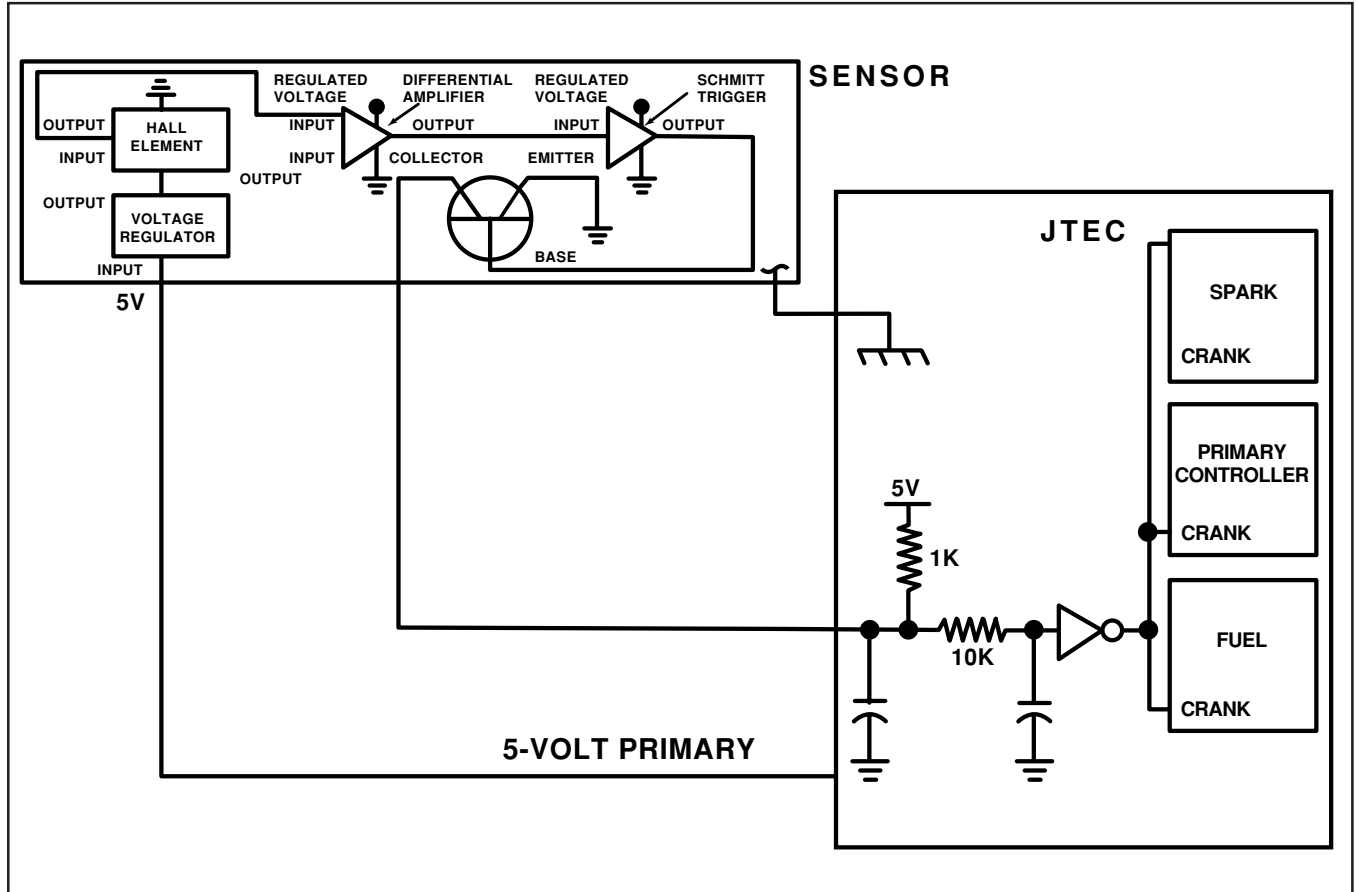

Figure 19 Camshaft Position Sensor Circuit

## 8.0L – V10 Fuel Injection

Similar to the CKP, when the step passes in front of the CMP, the 5 volt reference voltage from the PCM goes to approximately 0 volts. When the step rotates away from the sensor, the reference voltage returns to 5 volts. The result is a square wave signal that alternates between 0 and 5 volts (fig. 20).

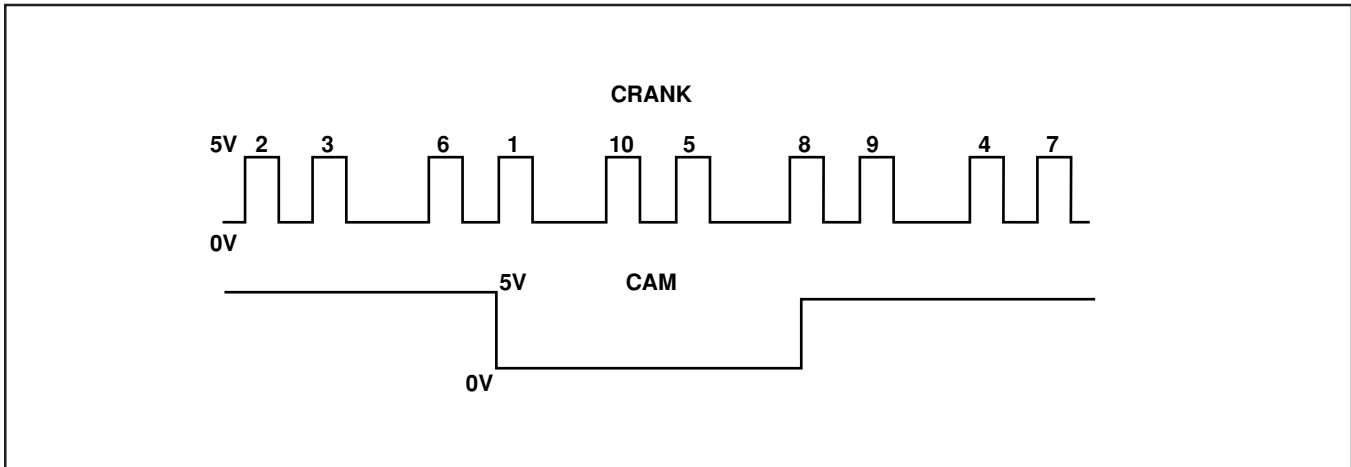

Figure 20 CMP Sensor Signal

The PCM determines crankshaft position from the inputs provided by the camshaft and crankshaft position sensors. Once the crankshaft position is determined the PCM can synchronize fuel injection and cylinder identification.

**In order for the vehicle to start, both the CMP and CKP sensor signals must be present. On 1996 vehicles, both CMP and CKP sensor signals are necessary for continued engine operation.**

**On 1997 vehicles, once the engine is running, the CMP sensor signal is not needed for continued engine operation.**

When the PCM sees the falling edge of the CMP sensor it knows that cylinder number 1 is next. So when the PCM sees the second falling edge after the CMP sensor it knows that the crankshaft is at 9° BTDC compression for cylinder #1. The PCM then knows that the next falling edge it will see is 9° BTDC compression for cylinder #10 and so on. Because of the odd fire the injector-firing is also staggered. The injectors for cylinders 1, 9, 3, 5 and 7 are fired at 423° BTDC. The injectors for cylinders 10, 4, 6, 8 and 2 are fired at 441° BTDC.

### CAM/CRANK DIAGNOSIS

In order for the PCM to diagnose either the CAM or CRANK sensor signals, one of the signals must be present.

### CAMSHAFT POSITION SENSOR SERVICE

**CAUTION:** *When installing a CMP sensor the cam drive gear position must be checked. If the cam gear is positioned at the low area, the sensor will be broken when the engine is started. See service manual for proper procedures.*

# 8.0L – V10 Fuel Injection

## ACTIVITY 3 — CAMSHAFT POSITION SENSOR ACTIVITY

### BR

#### Activities

1. Find the sensor on the vehicle and unplug the connector.
2. Using a voltmeter, measure the voltage on the three pins. What are the voltages?  
Supply \_\_\_\_\_ Sense \_\_\_\_\_ Ground \_\_\_\_\_
3. Connect the DRB III and go to Monitors and then No Start.
4. Crank the engine. What does the DRB show for camshaft and crankshaft operating indicators? \_\_\_\_\_
5. Change the DRB to read DTCs. What DTCs are present? \_\_\_\_\_
6. Leave DRB at DTC screen and turn the key to OFF. Plug the camshaft position sensor connector together.
7. Using the breakout box, short the camshaft sensor 5 volt primary to ground.  
Will the engine start? \_\_\_\_\_  
What happened to the DRB III? \_\_\_\_\_
8. Remove the ground from the 5 volt primary. What fault codes are present?  
\_\_\_\_\_



# 8.0L – V10 Fuel Injection

## SR

### Activities

1. Find the sensor on the vehicle and unplug the connector.
2. Using a voltmeter, measure the voltage on the three pins. What are the voltages?  
Supply \_\_\_\_\_ Sense \_\_\_\_\_ Ground \_\_\_\_\_
3. Connect the DRB III and go to Monitors and then No Start.
4. Crank the engine. What does the DRB show for camshaft and crankshaft operating indicators? \_\_\_\_\_
5. Change the DRB to read DTCs. What DTCs are present? \_\_\_\_\_
6. Leave DRB at DTC screen and turn the key to OFF. Plug the camshaft position sensor connector together.
7. Using the breakout box, short the camshaft sensor 5 volt primary to ground.  
Will the engine start? \_\_\_\_\_  
What happened to the DRB III? \_\_\_\_\_
8. Remove the ground from the 5 volt primary. What fault codes are present?  
\_\_\_\_\_

# 8.0L - V10 Fuel Injection

## MANIFOLD ABSOLUTE PRESSURE (MAP) SENSOR

The MAP signal serves as a PCM input, using a silicon-based (SR) or ceramic-based (BR) sensing unit to provide data on the manifold vacuum that draws the air/fuel mixture into the combustion chamber. The PCM requires this information to determine injector pulse width and spark advance. When MAP voltage (engine running) equals the voltage seen when barometric pressure was learned or updated, the pulse width will be at it's maximum.

Also, like the cam and crank sensors, 5 volts is supplied from the PCM and the MAP sensor returns a voltage signal to the PCM that reflects manifold pressure (fig. 21). The MAP sensor operating range is from 0.45 volt (high vacuum) to 4.8 volts (low vacuum). The sensor is supplied a regulated 4.8 to 5.1 volts to operate the sensor. Like the cam and crank sensors, ground is provided through the sensor return circuit

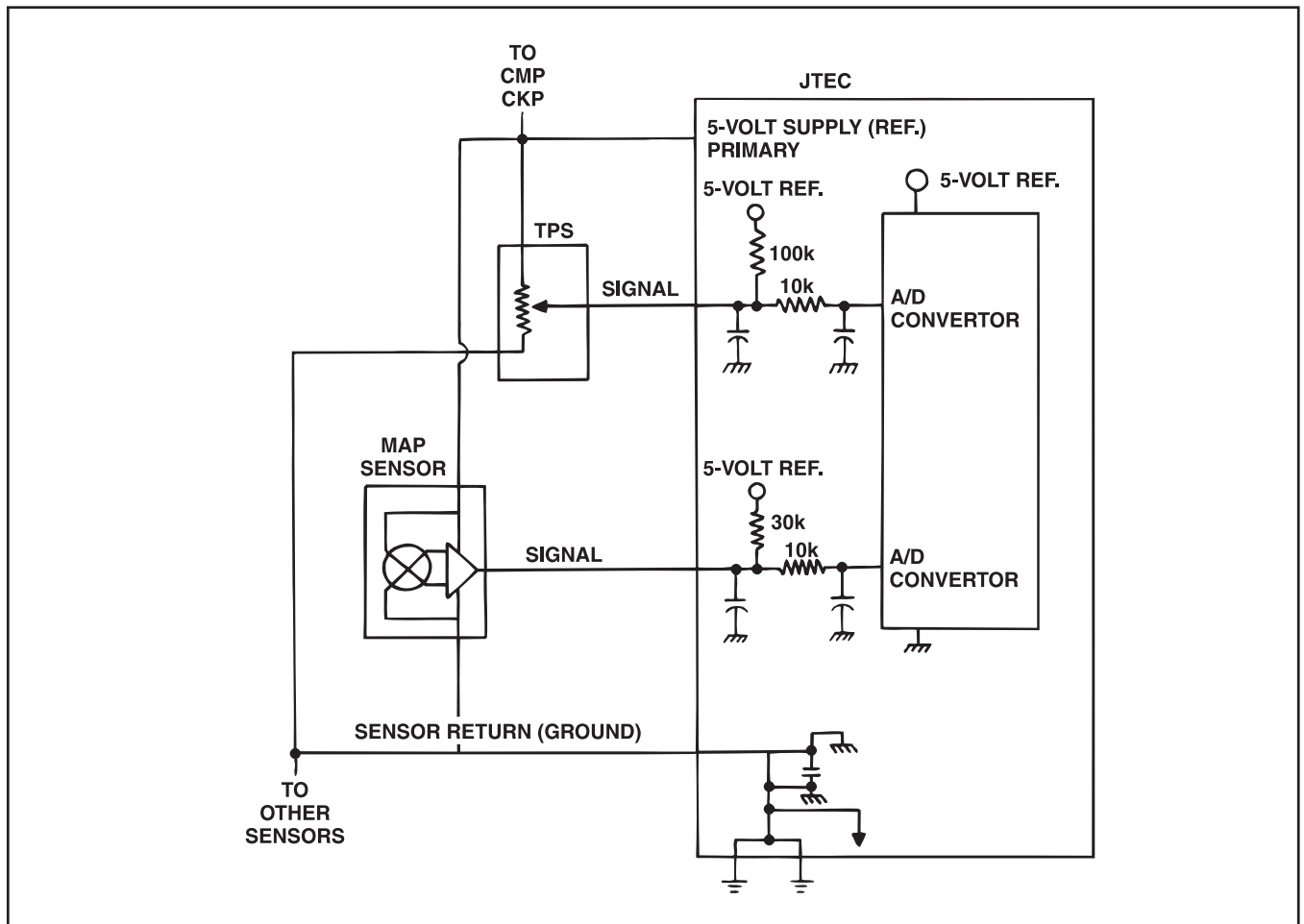

Figure 21 Manifold Absolute Pressure Sensor Circuit

## 8.0L - V10 Fuel Injection

The MAP sensor input is the number one contributor to pulse width. An important function of the MAP sensor is to determine barometric pressure (fig. 23). The PCM needs to know if the vehicle is at sea level, or in Denver at 5,000 feet above sea level, because the air density changes with altitude. It will also help to correct for varying weather conditions. This is important, because as air pressure changes, barometric pressure changes. Barometric pressure and altitude have a direct inverse correlation; as altitude goes up, barometric pressure goes down. The first thing that happens as the key is rolled on, before reaching the crank position, the PCM powers up, comes around and looks at the MAP voltage, and based upon the voltage it sees, it knows the current barometric pressure relative to altitude.

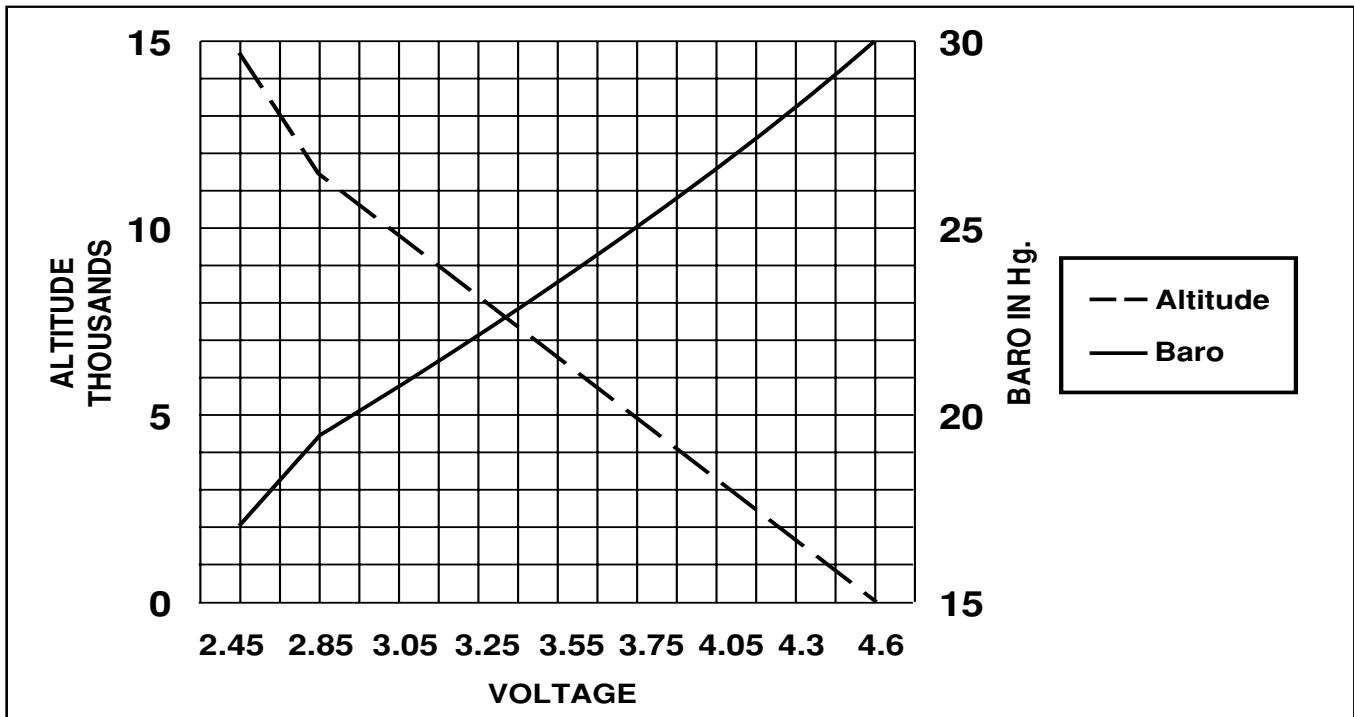

Figure 22 MAP Sensor Voltage Values

## 8.0L - V10 Fuel Injection

Once the engine starts, the PCM looks at the voltage again at the trailing edge of the last slot on the current cylinder and the leading edge of the first slot of the next cylinder. These two values are added and then divided by 2 to get an average. It then averages these signals and compares the current voltage to what it was at key ON. The difference between current voltage and what voltage was at key ON, is manifold vacuum (fig. 24).

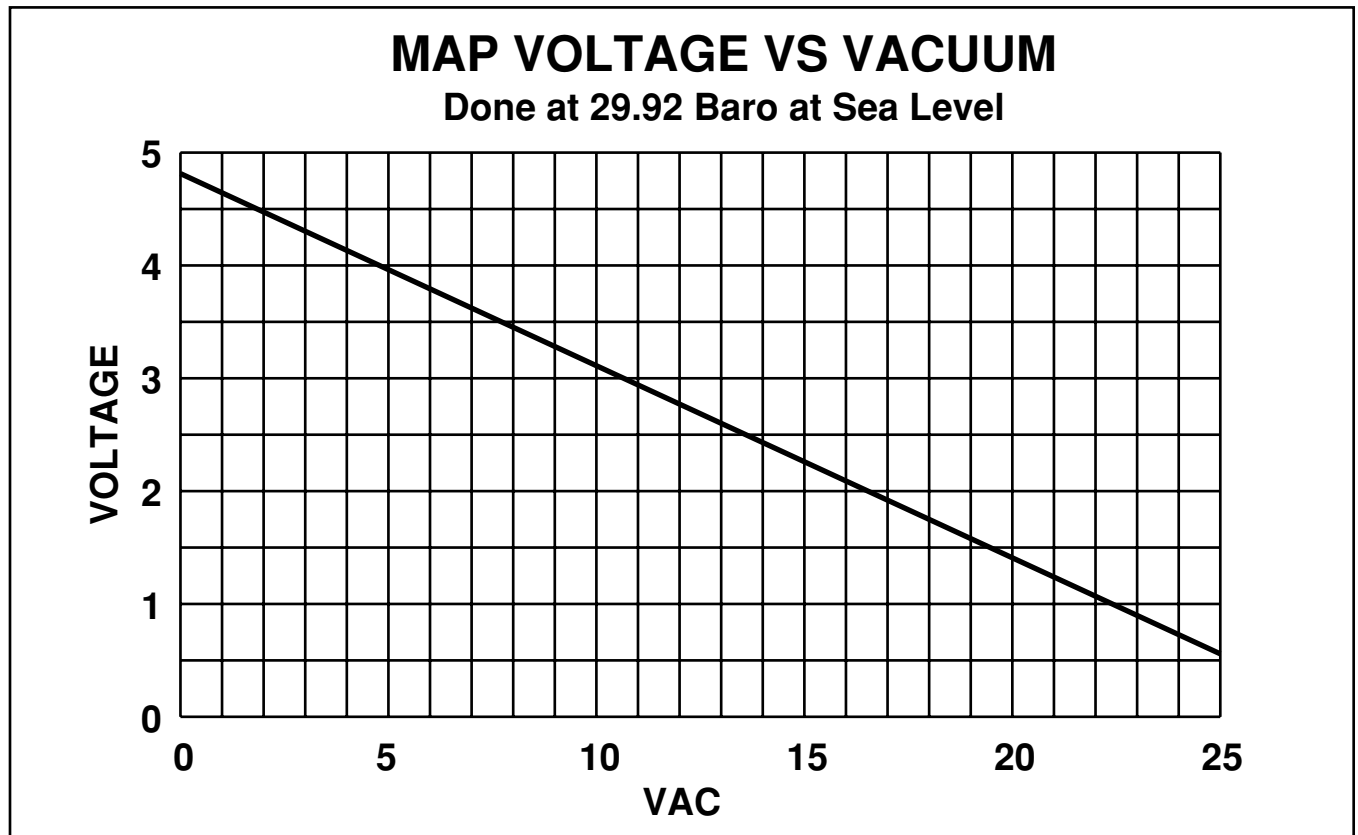

Figure 23 MAP Voltage vs. Vacuum

During key ON (engine not running) the sensor reads (updates) barometric (Baro) pressure. A normal range can be obtained by monitoring a known, good sensor.

As the altitude increases, the air becomes thinner (less oxygen). If a vehicle is started and driven to a very different altitude than where it was at key ON, the barometric pressure must be updated. Anytime the PCM sees at least 1.8 volts above minimum TPS, and based upon rpm, it will update barometric pressure in the MAP memory cell. With periodic updates, the PCM can make its calculations more effectively. Also, if MAP is ever greater than Baro, such as coming down from a high altitude, Baro automatically updates.

The PCM uses the MAP sensor to aid in calculating the following:

- Barometric pressure.
- Engine load.
- Manifold pressure.
- Injector pulse width.
- Spark-advance programs.
- IAC position.
- Deceleration fuel shutoff.

## 8.0L – V10 Fuel Injection

The PCM recognizes a decrease in manifold pressure by monitoring a decrease in voltage from the reading stored in the barometric pressure memory cell. The MAP sensor is a linear sensor. As pressure changes, voltage changes proportionately. The range of voltage output from the sensor is usually between 4.6 volts at sea level to as low as 0.3 volt at 26 in. Hg. of manifold vacuum (Table 2). Barometric pressure is the pressure exerted by the atmosphere upon an object. At sea level, on a standard day, no storm, barometric pressure is 29.92 in Hg. For every 100 feet of altitude, barometric pressure drops 0.10 in Hg. A storm can either add (high pressure) or decrease (low pressure) from what should be present for that altitude. You should know the average pressure and corresponding barometric pressure for your area. Always use the Diagnostic Test Procedures Manual for MAP sensor testing.

<b>Inches of Mercury Absolute</b>	<b>Inches of Mercury Vacuum</b>	<b>MAP Sensor Signal Voltage (volts)</b>
<b>31.0</b>	<b>0.5 psi</b>	<b>4.8</b>
<b>29.92</b>	<b>0.00</b>	<b>4.6</b>
<b>27.00</b>	<b>2.92</b>	<b>4.1</b>
<b>25.00</b>	<b>4.92</b>	<b>3.8</b>
<b>23.00</b>	<b>6.92</b>	<b>3.45</b>
<b>20.00</b>	<b>9.92</b>	<b>2.92</b>
<b>15.00</b>	<b>14.92</b>	<b>2.09</b>
<b>10.00</b>	<b>19.92</b>	<b>1.24</b>
<b>5.00</b>	<b>24.92</b>	<b>0.45</b>

Table 2 MAP Sensor Values

### SR

The MAP sensor signal is provided from a single silicone piezoresistive element located in the center of a diaphragm. The element and diaphragm are both made of silicone. As the pressure changes, the diaphragm moves, causing the element to deflect, which stresses the silicone. When silicone is exposed to stress, its resistance changes. As manifold vacuum increases, the MAP sensor input voltage decreases proportionally. The sensor also contains electronics that filters the signal and provides temperature compensation.

### BR

The MAP sensor signal is provided from a ceramic capacitive pressure transducer. A ceramic wafer is bonded to a diaphragm. As the pressure changes the ceramic moves, causing the distance between the ceramic wafer and the diaphragm to change. This causes the capacitive value between the two to change. As manifold vacuum increases, the MAP sensor voltage decreases proportionally.

Even though the MAP sensors are made of different materials, the operation is the same resulting in the PCM seeing the same value.

# 8.0L – V10 Fuel Injection

## MAP Sensor Diagnostics

There are three MAP sensor diagnostic routines:

- MAP voltage too high (voltage is above 4.9 volts).
- MAP voltage too low (voltage below 2.35 volts at start-up or below .1 volt with engine running).
- No change in MAP voltage at start-to-run transfer.

With the engine running between 400 to 1,500 rpm, near closed throttle and if MAP voltage is above 4.9 volts, the voltage high fault is set. Beginning with the 1997 model year, the MAP diagnostic range is 416 to 3,500 rpm.

There are two different ways to set the voltage low fault. If MAP voltage is below 2.35 volts at start-up, the fault will be set. The other is MAP voltage below 0.1 volt while the engine is running.

To set the rationality fault, no change in MAP from start to run, the PCM must see too small a difference between engine MAP voltage running and Baro at key on. This is checked at all times. If rpm becomes close to idle speed and the throttle is closed, vacuum should be greater than a calibrated amount. If vacuum is not high, then a fault will be set.

MAP voltage is only looked at when the vehicle is near closed throttle and rpm between approximately 400 to 1,500 rpm. This means that if a MAP sensor is faulty at an rpm above 1,500, the PCM will believe whatever reading it gets from the MAP sensor as real. Beginning with the 1997 model year, the MAP diagnostic range is 416 to 3,500 rpm.

## MAP Sensor Limp-in

The PCM stores a DTC when the MAP sensor malfunctions. When the PCM sets a DTC, the MAP sensor's information is considered inaccurate. At this point, the PCM moves into "limp-in" mode. Limp-in for the MAP sensor allows the engine to continue to function, without input to the PCM from the MAP. The PCM must calculate the amount of air being consumed by the engine, which is accomplished by calculating MAP values, based upon readings from the CKP sensor (RPM) and the Throttle Position Sensor (TPS). Anytime the PCM sets a DTC for MAP, the Malfunction Indicator Light (MIL) is illuminated.

# 8.0L - V10 Fuel Injection

## Component Locations

The MAP sensor on V10 Dodge Truck engines is located on the right side of the intake manifold (fig 24). On Viper engines, it is located on the side of the intake manifold at the rear.

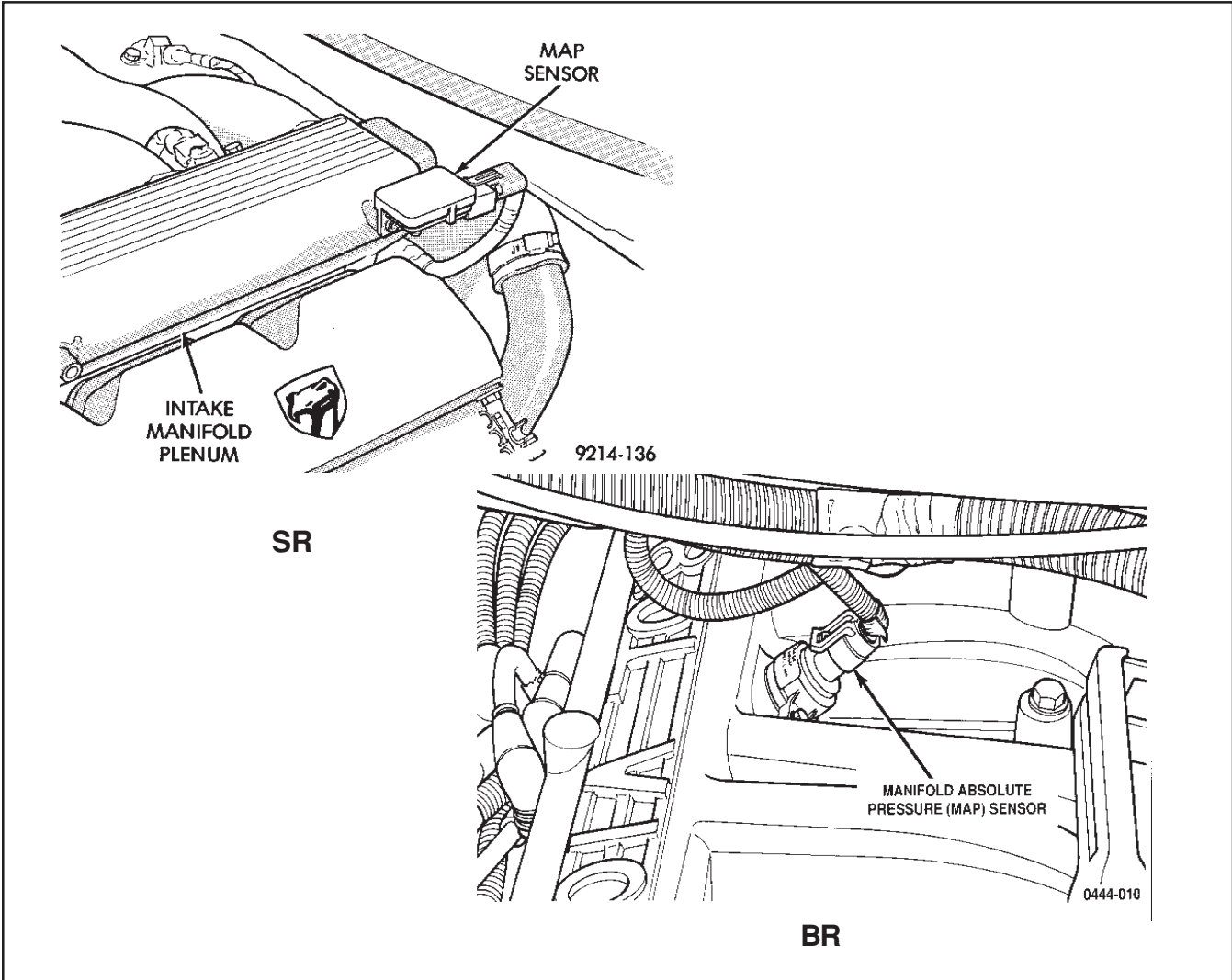

Figure 24 Manifold Absolute Pressure Sensor

# 8.0L – V10 Fuel Injection

## ACTIVITY 4 — MANIFOLD ABSOLUTE PRESSURE (MAP) SENSOR

### BR

#### Activities

1. Find the sensor on the vehicle and unplug the connector. How many wires does it have? \_\_\_\_\_
2. Using a voltmeter, measure the voltage on the three wires. What are the voltages? Supply \_\_\_\_\_ Sense \_\_\_\_\_ Ground \_\_\_\_\_
3. What does the DRB III indicate for Baro \_\_\_\_\_ Vacuum \_\_\_\_\_ voltage \_\_\_\_\_?
4. Using a jumper wire connect center terminal of connector to ground. What is the MAP voltage on the DRB? \_\_\_\_\_
5. Remove jumper wire. Change the DRB III to read DTCs. What DTC is present and why \_\_\_\_\_
6. Change the DRB to read sensors. Start the engine. Now what does the DRB indicate for Baro \_\_\_\_\_ Vacuum \_\_\_\_\_ and Voltage \_\_\_\_\_ ?
7. Plug the connector together.
8. Now what does the DRB indicate for Baro \_\_\_\_\_ Vacuum \_\_\_\_\_ and voltage \_\_\_\_\_?
9. Go to DTCs. What DTC is present and why? \_\_\_\_\_
10. If the MAP sensor wire was shorted to ground, what DTC would be present?  
\_\_\_\_\_
11. Using the simulator and DRB III, change the MAP output to read 17" of Hg. What happened to the IAC, target idle and injector pulse width? \_\_\_\_\_
12. Slowly decrease the MAP signal toward low vacuum. As you decreased the voltage, what happened to the vacuum? \_\_\_\_\_  
Why? \_\_\_\_\_



# 8.0L – V10 Fuel Injection

## SR

### Activities

1. Find the sensor on the vehicle and unplug the connector. How many wires does it have? \_\_\_\_\_
2. Using a voltmeter, measure the voltage on the three wires. What are the voltages? Supply \_\_\_\_\_ Sense \_\_\_\_\_ Ground \_\_\_\_\_
3. What does the DRB III indicate for Baro \_\_\_\_\_ Vacuum \_\_\_\_\_ voltage \_\_\_\_\_?
4. Using a jumper wire connect center terminal of connector to ground. What is the MAP voltage on the DRB? \_\_\_\_\_
5. Remove jumper wire. Change the DRB III to read DTCs. What DTC is present and why \_\_\_\_\_
6. Change the DRB to read sensors. Start the engine. Now what does the DRB indicate for Baro \_\_\_\_\_ Vacuum \_\_\_\_\_ and Voltage \_\_\_\_\_ ?
7. Plug the connector together.
8. Now what does the DRB indicate for Baro \_\_\_\_\_ Vacuum \_\_\_\_\_ and voltage \_\_\_\_\_?
9. Go to DTCs. What DTC is present and why? \_\_\_\_\_
10. If the MAP sensor wire was shorted to ground, what DTC would be present? \_\_\_\_\_
11. Using the simulator and DRB III, change the MAP output to read 17" of Hg. What happened to the IAC, target idle and injector pulse width? \_\_\_\_\_
12. Slowly decrease the MAP signal toward low vacuum. As you decreased the voltage, what happened to the vacuum? \_\_\_\_\_  
Why? \_\_\_\_\_

# 8.0L - V10 Fuel Injection

## THROTTLE POSITION SENSOR (TPS)

The throttle position sensor is mounted to the side of the throttle body. The PCM needs to identify the actions of the throttle blade at all times to assist in performing the following calculations:

- Ignition timing advance.
- Fuel injection pulse-width.
- Idle (learned value or minimum TPS).
- Off-Idle (0.04 volt above minimum TPS).
- Wide-Open Throttle (WOT) open loop (2.6 volts above learned idle voltage).
- Deceleration fuel lean-out.
- Fuel cutoff during cranking at WOT (2.6 volts above learned idle voltage).

The PCM supplies the TPS with a regulated voltage that ranges from 4.8 to 5.1 volts (fig. 25). This regulated output voltage is the same regulated voltage that the MAP, cam and crank sensors use. The TPS receives its ground from the PCM. The input of the TPS to the PCM is through a 5-volt sensor circuit.

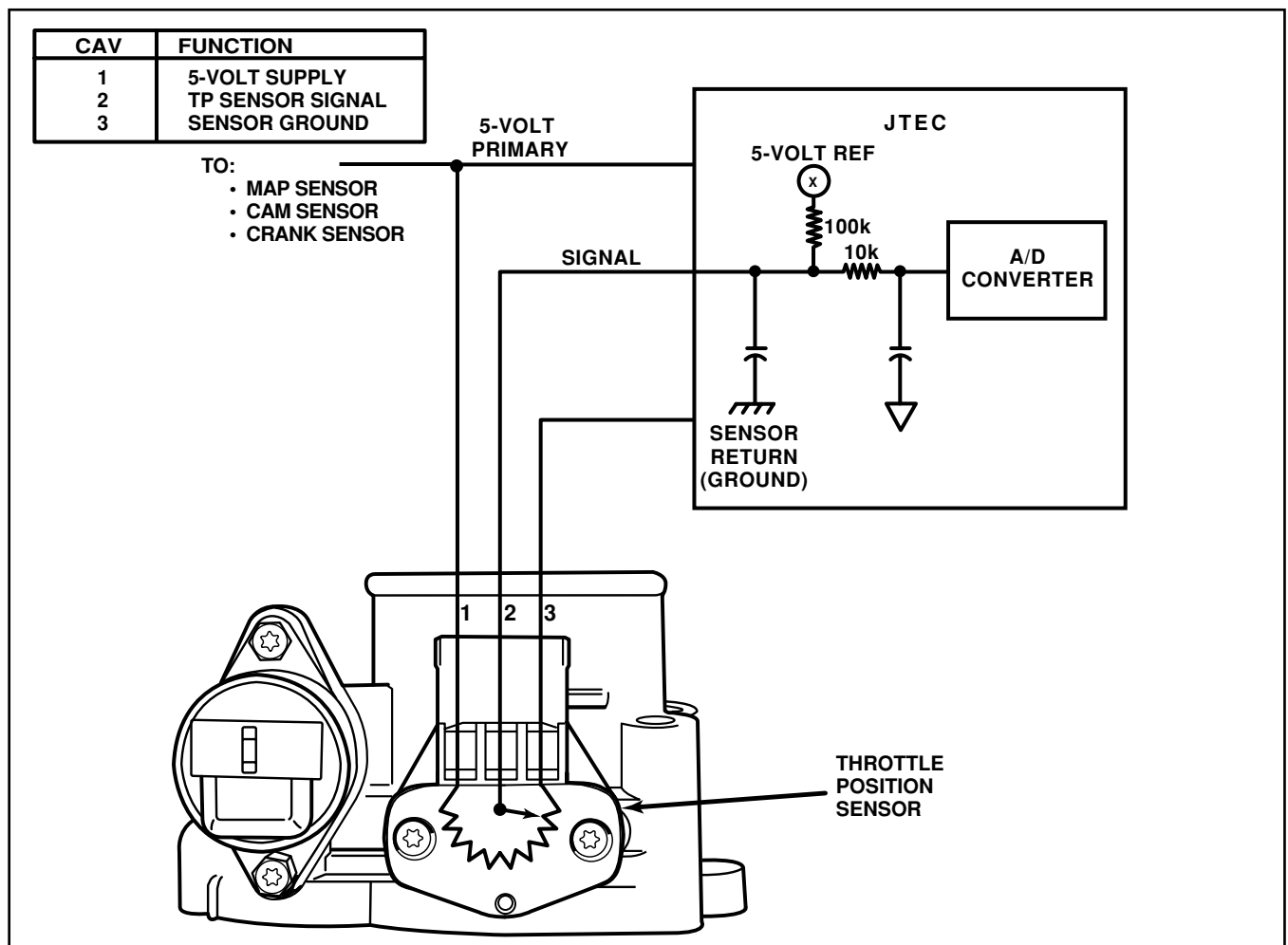

Figure 25 Throttle Position Sensor Circuit

# 8.0L – V10 Fuel Injection

## TPS PROGRAMS

### Idle

As with other Chrysler fuel-injection systems, the PCM is able to recognize an idle command based upon inputs from the TPS. Also, like other Chrysler systems, the PCM is programmed to monitor the TPS signal whenever the key is ON. While the key is on and the engine is running, the PCM assumes that the lowest voltage it can receive, above the fault threshold, must be where the throttle blade lever hits the idle stop. Normally, this voltage range is approximately 0.5-1.0 volt. At the low-voltage position, the PCM records the signal as “idle,” better known as “minimum TPS.”

The PCM's memory is updated anytime the sensed voltage is less than the recorded value in the memory cell. The PCM uses voltage change to determine when the throttle has returned to the previously learned value. At key ON, the PCM will raise the target voltage value in the TPS Min idle memory cell by approximately 0.04 of a volt. This new value becomes the new minimum TPS. When the engine is started, if the actual TPS voltage is lower than the new memory value, the PCM will store actual as minimum TPS.

If the key is cycled ON without starting the engine (start-to-run transfer), the value in target memory will increase up to a maximum of approximately 1.0 volt. Once the maximum is reached, the voltage will automatically drop to approximately 0.86 volt. At the next key-on it will increment 0.04 volt and will stay in this loop until it can learn a new actual minimum with the engine running. Limiting the upper threshold of minimum TPS reduces the chance that minimum TPS would get so high that the clear flood function would not work.

Anytime the PCM receives the idle voltage signal, the PCM is programmed to maintain target idle, using timing and the Idle Air Control (IAC) motor. Idle speed may vary, based on ECT.

Spark advance curves and injection pulse-width programs are unique as they are specifically calibrated for idle conditions. If equipped with an automatic transmission, the PCM also has separate programs for idle neutral and idle drive.

### Off-Idle

Once the throttle is opened, the PCM moves into its off-idle program at approximately 0.04 volt above minimum TPS. At this point, spark scatter advance is no longer being used to control idle speed. The IAC motor has been repositioned to act like a dashpot. The dashpot function operates the IAC motor, to prevent the possibility of the engine dying out during a sudden deceleration. So, if the throttle blade is actually closed but the TPS voltage did not drop to minimum TPS (dirty throttle body) idle, quality will be poor: minimum TPS with engine running cannot be learned upward (higher voltage than minimum TPS to .04). Only a lower voltage can be learned.

### Acceleration

A rapid rise in TPS voltage within a specified time frame causes the injector pulse width to increase. The amount of pulse width increase is determined by the rate of voltage rise. For maximum response, the PCM will momentarily increase the pulse width for all the injectors.

# 8.0L – V10 Fuel Injection

## Wide Open Throttle (WOT)

With the engine running, the PCM spark-advance and fuel pulse-width programs are affected during WOT conditions. The PCM is programmed to go into open loop anytime the TPS voltage exceeds 2.7 volts (80% throttle blade) above minimum idle. This enables the PCM to enrich the air/fuel ratio at WOT to allow the combustion chamber to run a little cooler.

## Deceleration

Under deceleration, the PCM is programmed to “lean out” the air/fuel ratio, since engine power is not needed. One of the main components involved with the deceleration program is the TPS. If, while the vehicle is in motion (based on the Vehicle Speed Sensor), the TPS is closed, and manifold vacuum is high, the PCM narrows the pulse width, so that the air/fuel ratio becomes leaner. In some instances, the pulse width goes to 0.0 msec., at which time no fuel is supplied to the engine. This action causes extremely low vehicle emissions. During deceleration, the adaptive numerator is updated, as there is no load on the crankshaft. The adaptive numerator is explained in detail in the On Board Diagnostics II Student Workbook.

## Wide Open Throttle Fuel Cutoff During Cranking

One last function that the PCM performs from inputs delivered by the TPS is the WOT fuel cutoff, while cranking. To ensure short cranking times, the PCM fires all of the injectors simultaneously, once during cranking. After that, the PCM waits two revolutions, then fires the injectors sequentially. If the programmed pulse width allows too much fuel into the combustion chamber, or if circumstances do not allow the engine to start up with the programmed quantity of fuel, the driver can operate the accelerator pedal to WOT, so that the PCM de-energizes all injectors. This program occurs only during cranking and when the TPS voltage exceeds 2.4 volts above minimum TPS.

## TPS Diagnostics

There are three TPS diagnostic routines:

- TPS voltage high (above 4.9 volts).
- TPS voltage low (below 0.1 volts).
- TPS voltage does not agree with MAP.

The diagnostic routine “TPS voltage low” is set when TPS voltage is below 0.1 volt and engine speed is greater than 1500 rpm. The “TPS voltage high” routine is set when TPS voltage is above 4.9 volts and engine rpm is as follows: above 1500 rpm for 1996, or between 416-3500 rpm for 1997. The diagnostic routine “TPS voltage does not agree with MAP” fault is set when the PCM interprets the MAP indication as a load condition that does not agree with what it sees from the TPS. This can occur in two ways: TPS voltage less than 1.16 volts with vacuum less than 2”, or TPS voltage more than 2.16 volts and vacuum greater than 11.8”.

## TPS Limp-in

When the TPS indicates a voltage that is too low, too high or not believable, the PCM sets a DTC. When the DTC is set, the MIL is illuminated and the PCM moves into limp-in mode. Limp-in for the TPS is divided into three categories: idle, part-throttle and WOT. These limp-in values are mainly rpm-based, although the MAP sensor has an input to the program. Refer to the Diagnostic Test Procedures Manual for complete diagnostic information.

# 8.0L – V10 Fuel Injection

## ACTIVITY 5 – THROTTLE POSITION SENSOR

1. Create a custom display on the DRB III:
  - TPS voltage
  - TPS Calculated
  - MIN TPS
  - TPS %
  - MAP
  - Upstream O<sub>2</sub> voltage
  - Injector Pulse Width (while cranking)
  - IAC steps
  - Spark advance
2. Turn key ON and OFF several times. What happened to MIN TPS? Will clear-flood occur? \_\_\_\_\_
3. Disable ignition coils. With engine cranking and DRB III at sensors, move throttle. What happened to TPS and Injector Pulse Width? \_\_\_\_\_
4. Start engine. What happened to MIN TPS? \_\_\_\_\_
5. Connect fuel simulator (preset potentiometer). Change cranking pulse width to pulse width, raise TPS value at simulator. What happened? \_\_\_\_\_
6. Increase TPS value until open loop (upstream O<sub>2</sub>), watch pulse width and O<sub>2</sub> voltage. What did you see? Then return to MIN TPS \_\_\_\_\_  
\_\_\_\_\_
7. Rotate potentiometer downward, then raise it up. What did you notice TPS learning? \_\_\_\_\_
8. With TPS voltage at MIN TPS snap (rotate quickly) TPS, watch pulse width. What did you see? \_\_\_\_\_
9. Rotate potentiometer way down to 0 volts and move accelerator linkage. In what mode is the PCM? \_\_\_\_\_

# 8.0L - V10 Fuel Injection

## ENGINE COOLANT TEMPERATURE (ECT) SENSOR

The PCM uses inputs from the ECT sensor to calculate:

- Injector pulse width.
- Spark-advance curves.
- Idle Air Control (IAC) motor key-on steps.
- Initial fuel injection.
- O2 Sensor closed-loop times (30° and above).
- Purge solenoid on/off times.
- Radiator fan relay on/off points (Viper only).
- Target idle speed.

The ECT input is the second most powerful modifier of injector pulse width. The ECT sensor is a Negative Thermal Coefficient (NTC) sensor. The PCM sends five volts to the sensor, and is grounded through the sensor return line (fig. 26). As temperature increases, resistance in the sensor decreases (fig. 27).

As the temperature goes up, the voltage drop increases, which causes a lower voltage at the A/D converter. **Unlike prior years (SBEC), this is not a dual-ranging circuit.**

### 96 Coupe and 97 All Viper

The ECT sensor on the Viper V10 is a 4 wire sensor located in the front of the driver side cylinder head. Two wires are for the gauge and two for the sensor input to the PCM.

This sensor is used as a PCM input, a message center input for the dashboard warning light, and for the water temperature gauge.

### BR

The BR uses a two wire sensor that provides input to the PCM.

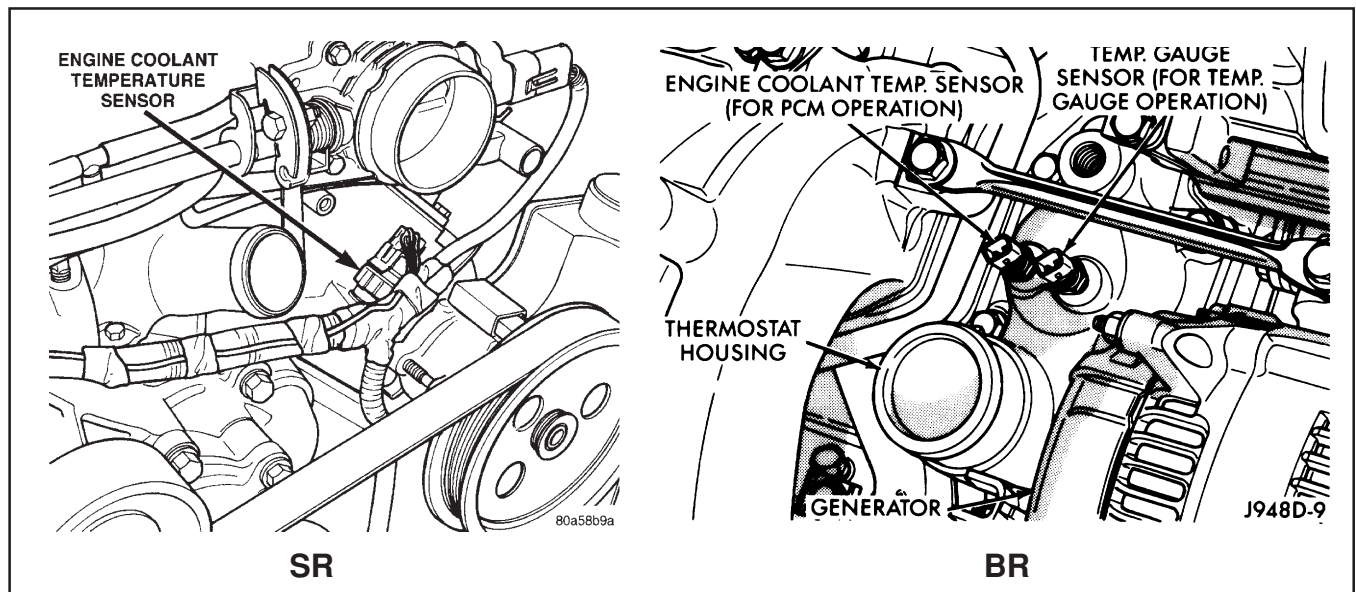
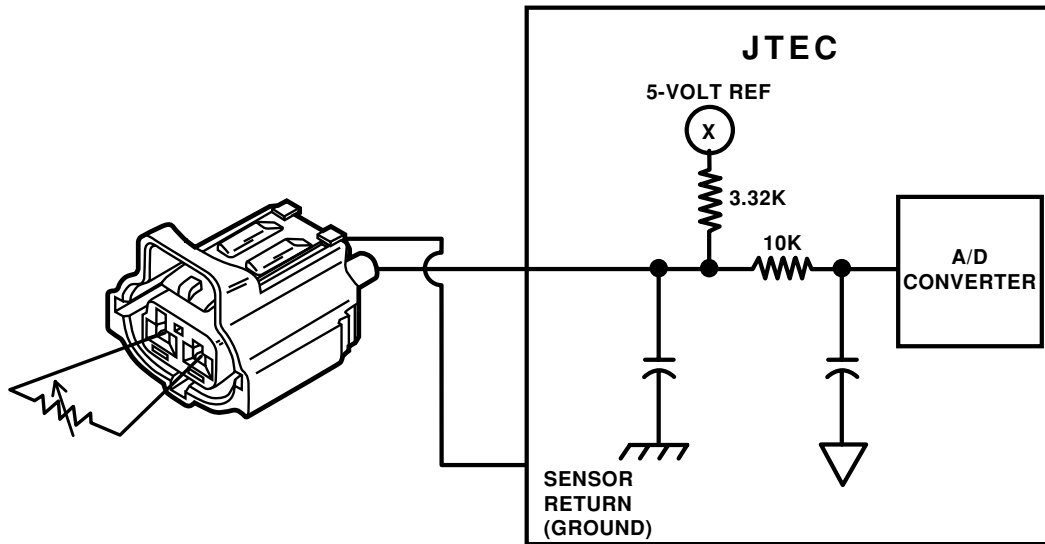
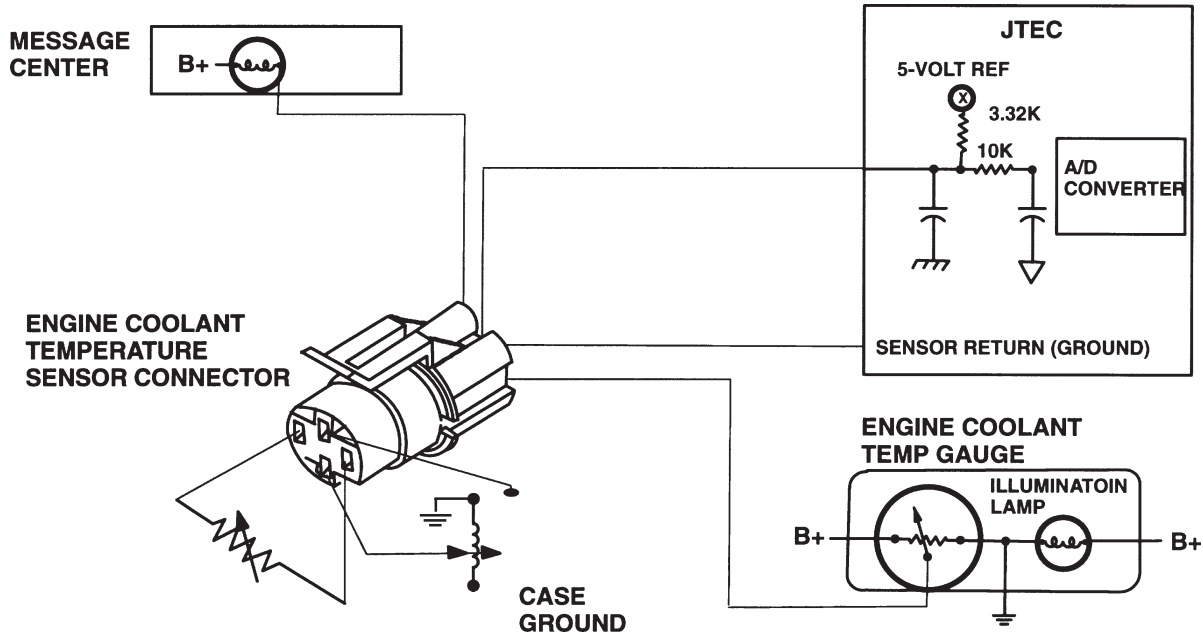

Figure 25a ECT Sensor Locations

# 8.0L - V10 Fuel Injection



BR



SR

Figure 26 Engine Coolant Temperature Sensor Circuit

# 8.0L - V10 Fuel Injection

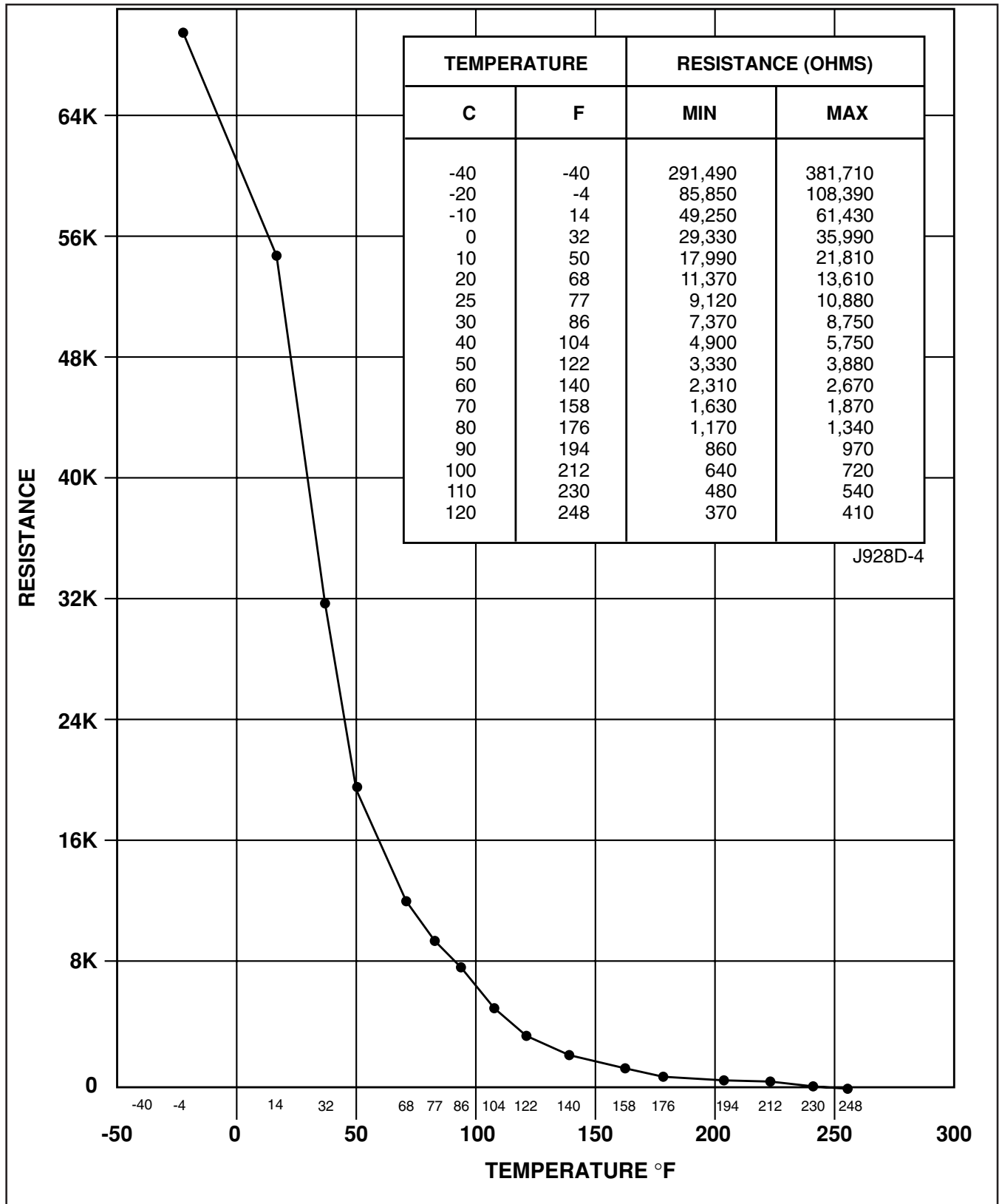

Figure 27 ECT/IAT Temperature/Resistance Curve



## 8.0L - V10 Fuel Injection

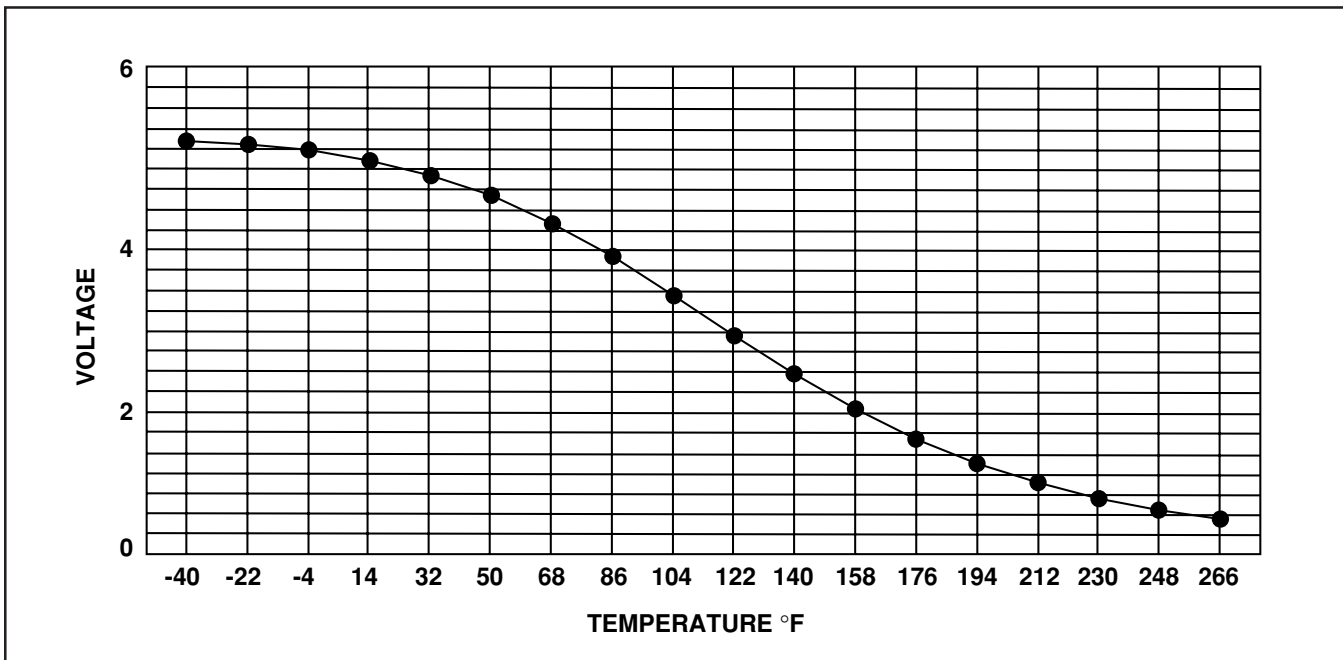

Figure 28 ECT/IAT Temperature/Voltage Curve

### ECT Sensor Diagnostics

There are four ECT diagnostic routines:

- ECT Too High is set when voltage is above 4.9 volts for 3 seconds.
- ECT Too Low is set when voltage is below 0.08 volt for 3 seconds.
- ECT Too-Cold, Too-Long Fault is set when the ECT is between 19° and 212°F at start-up and the engine runs for 14 minutes under any condition, then runs another 14 minutes above 28 mph and ECT does not reach 160°F.
- The closed loop temperature not reached, fault is set when the engine fails to reach a calibrated (approximately 50°F) temperature within approximately five minutes.

The two rationality faults (ECT too-cold too-long and closed-loop temperature not reached) will turn the “Check Engine” light on if the fault is present for two trips. For more information, refer to the OBD II course.

### ECT Sensor Limp-in

When the ECT sensor indicates voltage that is too high or too low, the PCM sets a DTC. When a DTC is set, the MIL is illuminated and the PCM moves into limp-in mode. Limp-in mode for the ECT sensor is a preset value and the radiator fan on a Viper operate at high speed.

# 8.0L – V10 Fuel Injection

## ACTIVITY 6 – ENGINE COOLANT TEMPERATURE SENSOR

### BR

#### Activities

1. Find the sensor on the vehicle and unplug the connector. What does the DRB III indicate for temperature and voltage? \_\_\_\_\_
2. Using a voltmeter, measure the voltage on the two wires. What is the voltage?  
\_\_\_\_\_
3. Plug the connector together and change the DRB III to read DTCs. What DTC is present and why? \_\_\_\_\_
4. If the ECT sensor wire was shorted to ground, what DTC would be present?  
\_\_\_\_\_
5. Connect BOB and DRB III. Build a custom display:
  - Coolant Temp Degrees
  - Coolant Temp Voltage
  - Engine RPM
  - Target Idle
  - Injector Pulse Width
  - Upstream O2 Voltage
  - Closed Loop Timer
  - IAC Steps
  - Spark Advance

Hook up ECT on simulator. Rotate potentiometer and watch values on custom display. Note RPM increase at high temperature. Repeat procedure with engine on. Then, short the circuit to ground.

6. Using the simulator and DRB III, change the ECT output to read 0° F. What happened to IAC, target idle and injector pulse width? \_\_\_\_\_  
Why? \_\_\_\_\_
7. Slowly increase the temperature toward hot. As the temperature increased, what happened to the voltage? \_\_\_\_\_  
Why? \_\_\_\_\_
8. Using the simulator and DRB III, change the ECT output to read 240° F. What happened to IAC, target idle and injector pulse width? \_\_\_\_\_  
Why? \_\_\_\_\_

# 8.0L – V10 Fuel Injection

## SR

### Activities

1. Find the sensor on the vehicle and unplug the connector. What does the DRB III indicate for temperature and voltage? \_\_\_\_\_
2. Using a voltmeter, measure the voltage on the four wires. What is the voltage? \_\_\_\_\_
3. Plug the connector together and change the DRB III to read DTCs. What DTC is present and why? \_\_\_\_\_
4. If the ECT sensor wire was shorted to ground, what DTC would be present? \_\_\_\_\_
5. Connect BOB and DRB III. Build a custom display:
  - Coolant Temp Degrees
  - Coolant Temp Voltage
  - Engine RPM
  - Target Idle
  - Injector Pulse Width
  - Upstream O2 Voltage
  - Closed Loop Timer
  - IAC Steps
  - Spark Advance

Hook up ECT on simulator. Rotate potentiometer and watch values on custom display. Note RPM increase at high temperature. Repeat procedure with engine on. Then, short the circuit to ground.

6. Using the simulator and DRB III, change the ECT output to read 0° F. What happened to IAC, target idle and injector pulse width? \_\_\_\_\_  
Why? \_\_\_\_\_
7. Slowly increase the temperature toward hot. As the temperature increased, what happened to the voltage? \_\_\_\_\_  
Why? \_\_\_\_\_
8. Using the simulator and DRB III, change the ECT output to read 240° F. What happened to IAC, target idle and injector pulse width? \_\_\_\_\_  
Why? \_\_\_\_\_

# 8.0L – V10 Fuel Injection

## Intake Air Temperature (IAT) Sensor

The IAT sensor sends information to the PCM on the density of the air entering the manifold, based upon temperature. The PCM uses this input to calculate:

- Injector pulse width.
- Adjustment of spark timing (to prevent knock with high-intake air temperatures).

The IAT sensor exerts more control at cold temperatures and during wide-open throttle (high rpm, low manifold vacuum). At a temperature of  $-20^{\circ}\text{F}$  and wide-open throttle, the PCM can increase fuel injector pulse width by as much as 37%, based upon input from the IAT sensor.

The PCM sends 5 volts to the sensor and is grounded through the sensor return line (fig. 28). As temperature increases, resistance in the sensor decreases. The resistance of the IAT sensor is the same as for the ECT sensor.

The IAT sensor and its circuit function exactly the same as the ECT sensor and its circuit. The IAT sensor is located in the intake manifold on a BR and in the air cleaner housing on SR. The Viper IAT has a plastic housing (fig. 30).

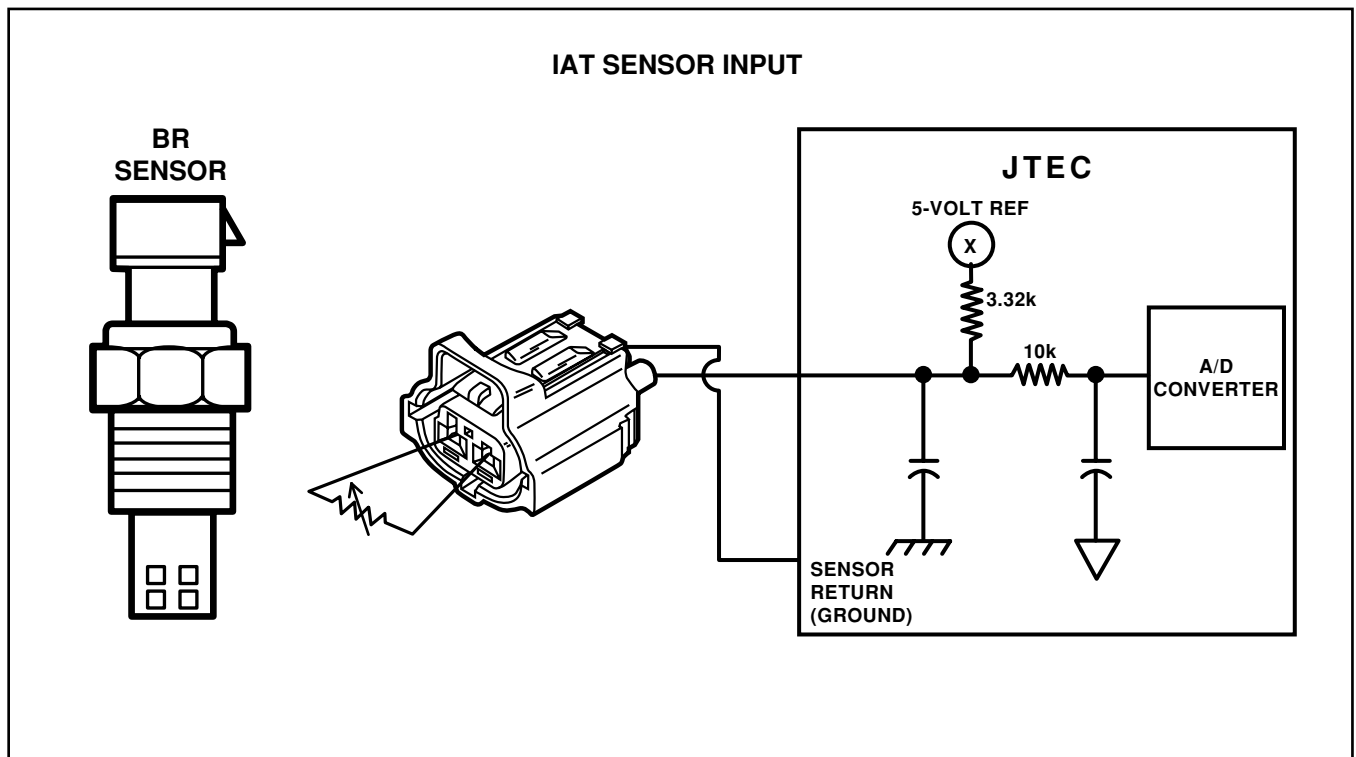

Figure 30 Intake Air Temperature Sensor Circuit

## 8.0L - V10 Fuel Injection

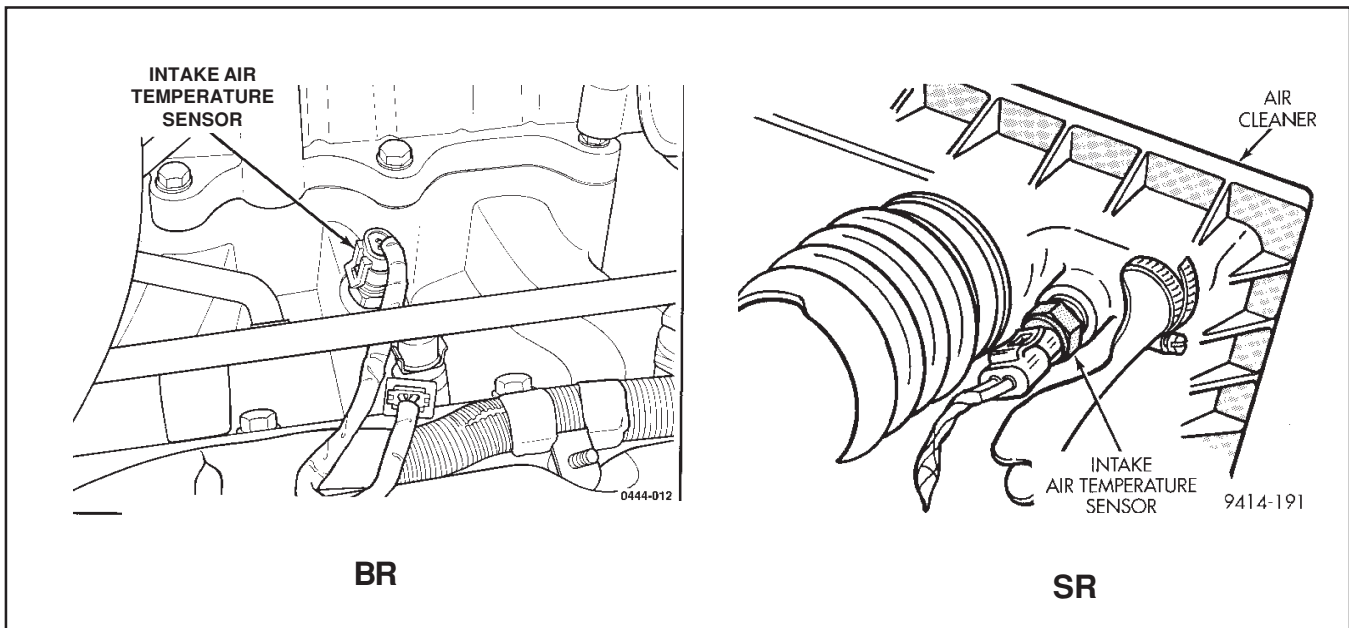

Figure 31 IAT Sensor

### IAT Sensor Diagnostics

- Voltage Too Low is set when voltage is below 0.1 volt
- Voltage Too High is set when voltage is above 4.9 volts

### IAT Sensor Limp-in

When the IAT sensor indicates voltage that is too high or too low, the PCM sets a DTC. When the DTC is set, the MIL is illuminated and the PCM moves into limp-in mode. The IAT sensor uses the BTS information, as long as the information is believed to be accurate. If the BTS is already in limp-in, the PCM uses a temperature that has very little effect on fuel and spark programming.

# 8.0L – V10 Fuel Injection

## ACTIVITY 7 – INTAKE AIR TEMPERATURE SENSOR

### Activities

1. Find the sensor on the vehicle and unplug the connector. What does the DRB indicate for temperature and voltage? \_\_\_\_\_
2. Using a voltmeter, measure the voltage on the two wires. What is the voltage?  
\_\_\_\_\_
3. Plug the connector together and change the DRB III to read DTCs. What DTC is present and why? \_\_\_\_\_
4. If the IAT sensor wire was shorted to ground, what DTC would be present?  
\_\_\_\_\_
5. Connect BOB and DRB III. Build a custom display:
  - Intake Temp Degrees
  - Intake Temp Voltage
  - Engine RPM
  - Target Idle
  - Injector Pulse Width
  - Upstream O2 Voltage
  - Closed Loop Timer
  - IAC Steps
  - Spark Advance

Hook up IAT on simulator. Rotate potentiometer and watch values on custom display. Repeat procedure with engine \_\_\_\_\_ on. Then, short the circuit to ground.

5. Using the simulator and DRB III, change the IAT output to read 0° F. What happened to IAC, target idle and injector pulse width? \_\_\_\_\_  
Why? \_\_\_\_\_
6. Slowly increase the temperature toward hot. As the temperature increased, what happened to the voltage? \_\_\_\_\_  
Why? \_\_\_\_\_

# 8.0L – V10 Fuel Injection

## **SENSED BATTERY VOLTAGE**

The direct battery circuit to the PCM is also used as a reference point to sense battery voltage.

## **Fuel Injectors**

Fuel injectors are rated for operation at a specific voltage. If the voltage increases, the plunger will open faster and further. Conversely, if voltage is low, the injector will open slowly and not as far. So, if sensed battery voltage drops, the PCM will increase pulse width to maintain the same volume of fuel through the injector.

## **Charging – (Truck/Coupe/97 Vipers)**

The PCM uses sensed battery voltage to verify that target charging voltage (determined by Battery Temperature Sensor) is being reached. To maintain the target charging voltage, the PCM will full-field the generator to 0.5 volt above target, then turn off to 0.5 volt below target. This will continue to occur at a rate of up to a 100 Hz frequency, 100 times per second.

## **Charging – 1996 Viper Roadster**

The charging system is turned on and off with the ignition switch. The amount of DC current produced by the generator is controlled by the voltage regulator contained within the generator. The circuitry is connected in series with the second rotor field terminal and ground.

# 8.0L – V10 Fuel Injection

## OXYGEN (O2) SENSORS

### General Information

V10 engines use an O2 sensor for each bank. On BR V10 engines sold with California emissions and all Vipers, there are also downstream O2 sensors. An O2 Sensor provides the PCM with a voltage signal (0–1 volt) inversely proportional to the amount of oxygen in the exhaust. In other words, if oxygen content is low, voltage output is high and vice versa. This information allows the PCM to adjust injector pulse width to achieve the air/fuel ratio necessary for proper engine operation and to control emissions.

An O2 Sensor must have a source of oxygen from outside of the exhaust stream for comparison. Current O2 Sensors receive their fresh oxygen (outside air) supply through the wire harness (fig. 32). This is why it is important to never solder an O2 Sensor connector, or pack the connector with grease.



## 8.0L – V10 Fuel Injection

The downstream sensor, located after the catalytic converter, produces an input signal similar to that of an upstream sensor, that the PCM uses for two purposes. One function is to verify catalytic converter efficiency, as part of required OBD II diagnostics. The other function is to provide fuel correction information, based on actual catalytic converter output (BR with California emissions only).

Both O<sub>2</sub> Sensors are zirconium dioxide, four-wire, and heated. The heaters on both sensors are fed battery voltage from the ASD relay, which is also controlled by the PCM (refer to ASD relay for more information). Both sensor heaters use a common ground. One of the other two wires is the input to the PCM and the last wire is the sensor ground. Both circuits are isolated from each other and the sensor housing.

The O<sub>2</sub> Sensor uses a Positive Thermal Coefficient (PTC) heater element. As temperature increases, resistance increases. At ambient temperatures around 70°F, the resistance of the heating element is approximately 6 ohms. As sensor temperature increases, resistance in the heater element increases. Even though these are heating elements, current flow is low. At 70°F, current flow is approximately 1.5 amps. As it approaches operating temperature, it drops to approximately 200 milliamps. This allows the heater to maintain the optimum operating temperature of approximately 1400°–1500°F. Although both sensors operate the same, physical differences, due to the environment in which they operate, keep them from being interchangeable.

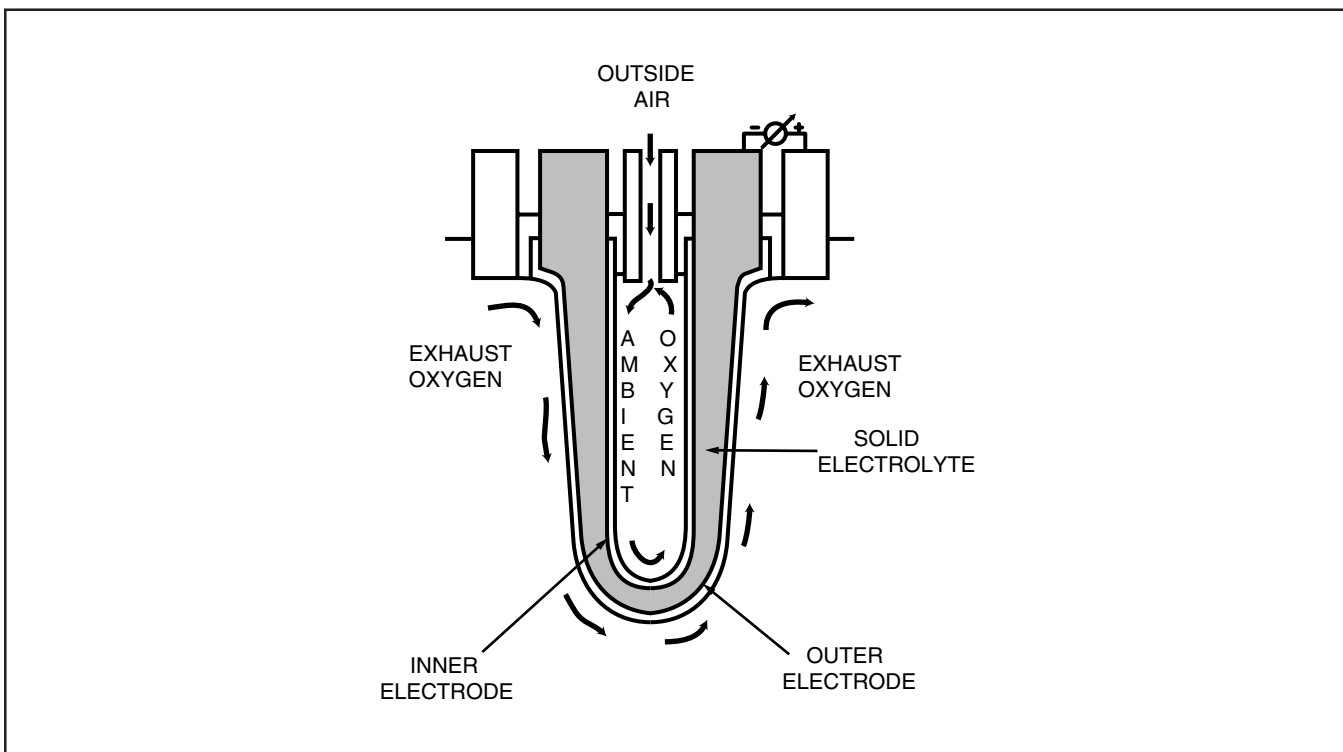

Figure 32 Oxygen Sensor Internal Operation

# 8.0L - V10 Fuel Injection

## Stoichiometric Ratio

Engineers found they could maximize catalyst efficiency to a point that would minimize hydrocarbon, carbon monoxide and oxides of nitrogen emissions, by controlling the air/fuel ratio. This (optimum) air/fuel ratio is 14.7 to 1 (ideal for both fuel efficiency and emission control). In other words, 14.7 units of air are mixed with every unit of fuel, to produce the minimum amount of emissions. The 14.7 to 1 ratio is called the stoichiometric (stoy-key-oh-met-rick) ratio (fig. 33).

However, conditions inside an engine's combustion chamber are not ideal. There just is not enough time in the engine's operating cycle to allow complete combustion to take place. So, even with a stoichiometric ratio, the engine's exhaust gases contain a certain percentage of pollutants in the form of HC and CO. The severe conditions (principally high temperatures) inside the combustion chamber cause some of the free oxygen and nitrogen in the air/fuel mixture to combine, forming various oxides of nitrogen ( $\text{NO}_x$ ). All things considered, the stoichiometric ratio is the optimum air/fuel ratio, for minimizing undesirable emissions.

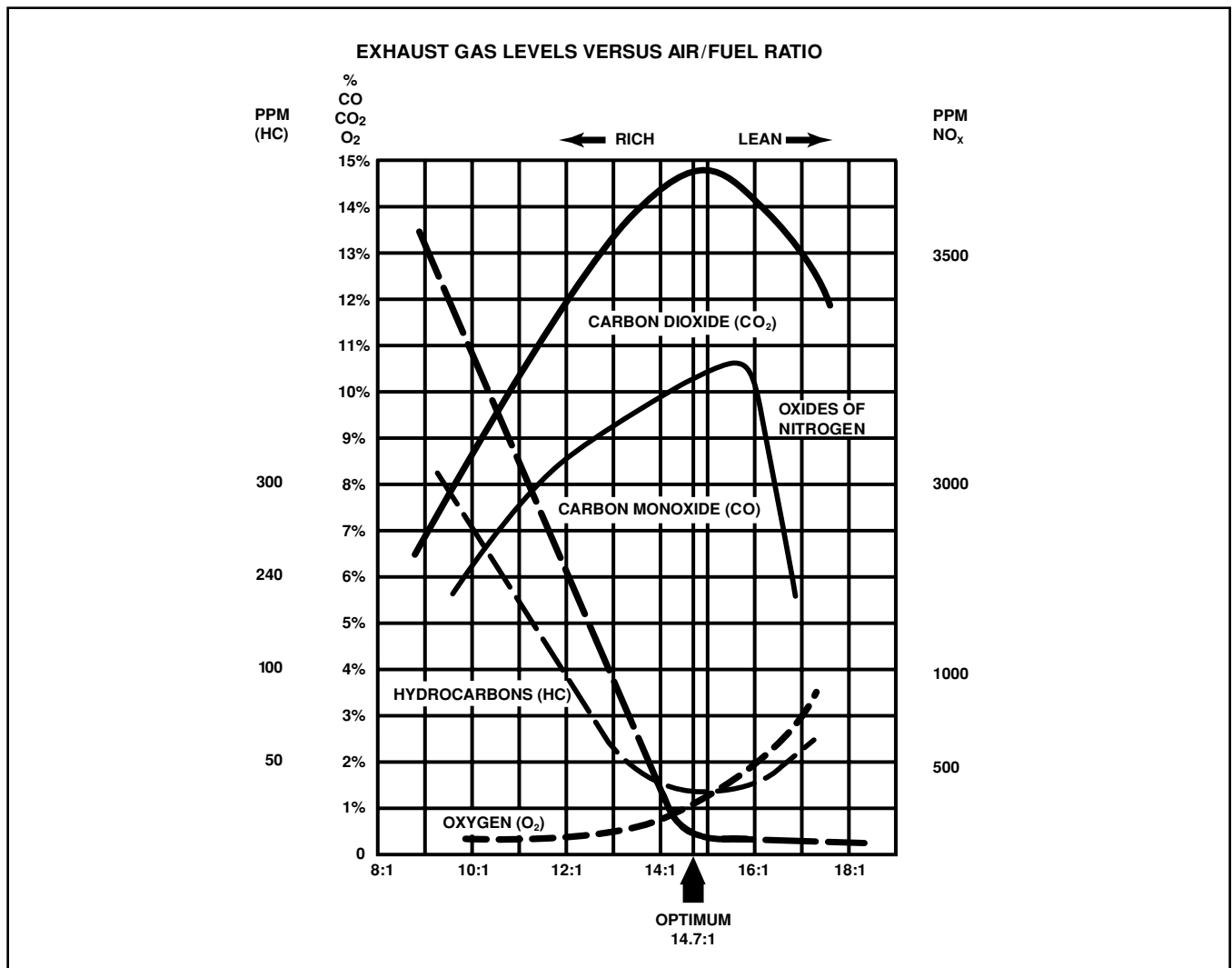

Figure 33 Exhaust Emissions vs. Air/Fuel Ratio

## 8.0L - V10 Fuel Injection

### Catalyst

The latest technology provides the use of a three-way catalytic converter on most automobiles. The three-way catalyst simultaneously converts three harmful exhaust emissions into harmless gases. Specifically, HC and CO emissions are converted into water ( $H_2O$ ) and carbon dioxide ( $CO_2$ ). Oxides of nitrogen ( $NO_x$ ) are converted into elemental nitrogen (N) and oxygen. The three-way catalyst is most efficient in converting HC, CO and  $NO_x$  at the stoichiometric air/fuel ratio of 14.7:1 (fig. 34). If the mixture becomes leaner than 14.7:1 (extra oxygen), the ability to convert  $NO_x$  drops. As the mixture becomes richer than 14.7:1 (less oxygen), the ability to convert HC and CO drops.

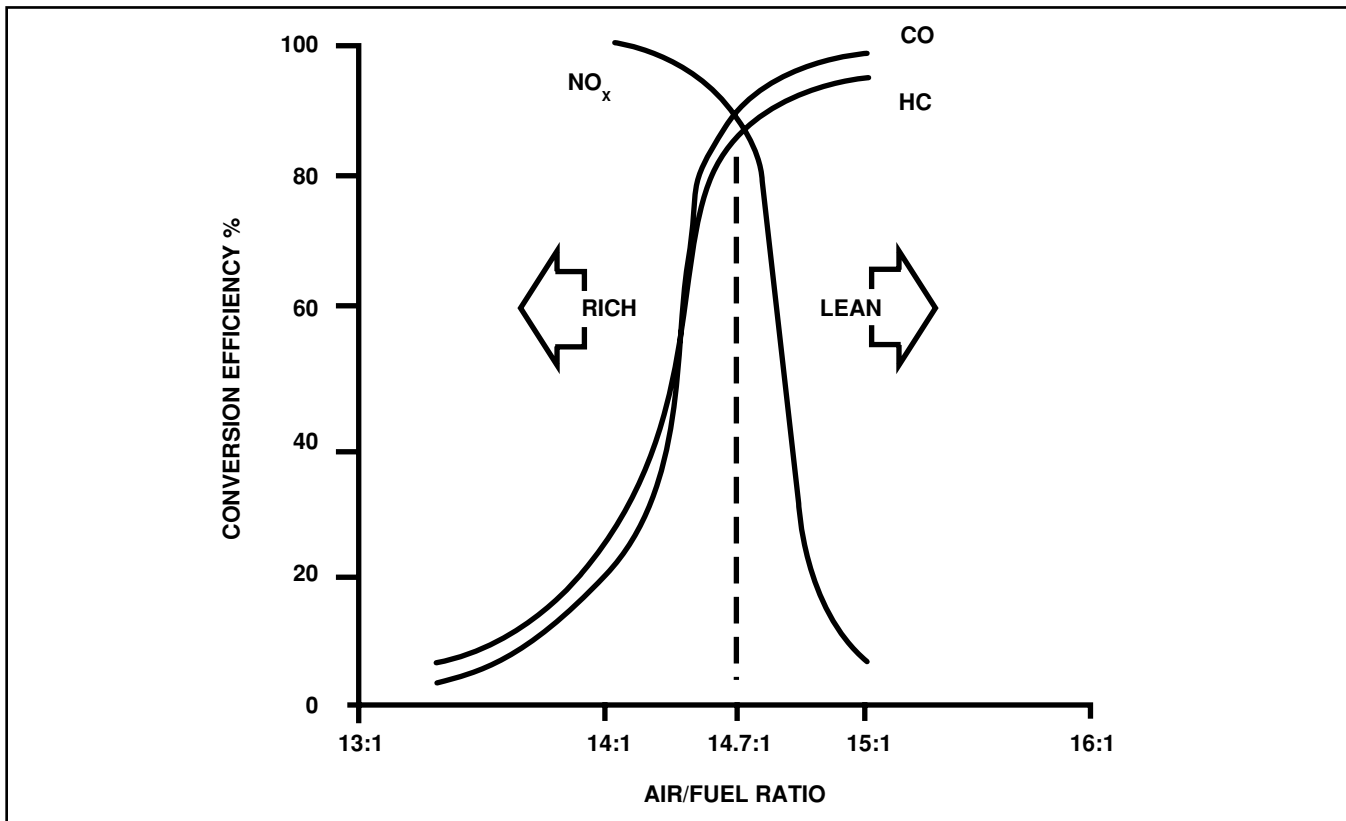

Figure 34 Conversion Efficiencies of a Three-Way Catalyst

# 8.0L – V10 Fuel Injection

## Upstream O2 Sensor

The upstream sensor is located on the exhaust manifold and is used to maintain an Air/Fuel (A/F) ratio of approximately 14.7:1 (stoichiometric). This is accomplished by the fact that an O2 Sensor acts like a switch when the A/F ratio is near 14.7:1 (fig. 36). When the A/F is lean (extra oxygen), the sensor output will be very close to 0 volt. As the A/F becomes richer (less oxygen), the sensor output will change rapidly to 0.5 volt and can continue movement up to 1 volt if the mixture becomes too rich (low oxygen). Based on these operating characteristics, the PCM can be programmed with switch points, to maintain the proper A/F ratio. The O2 Sensor must reach a minimum of 660°F in order to effectively monitor oxygen content in the exhaust system. To provide optimum functioning of the O2 Sensor, the PCM waits until the system goes into closed loop before it controls the air/fuel ratio; it does not attempt to control the ratio immediately after start-up.

Example of closed-loop parameters are:

- Engine temperature exceeds 35°F.
- O2 Sensor is in the ready mode.
- All timers have timed out, following the START to RUN transfer (the timer lengths vary, based upon engine temperature at key-on) as follows:
  - 35°F/41 sec.
  - 50°F/36 sec.
  - 70°F/19 sec.
  - 167°F/11 sec.

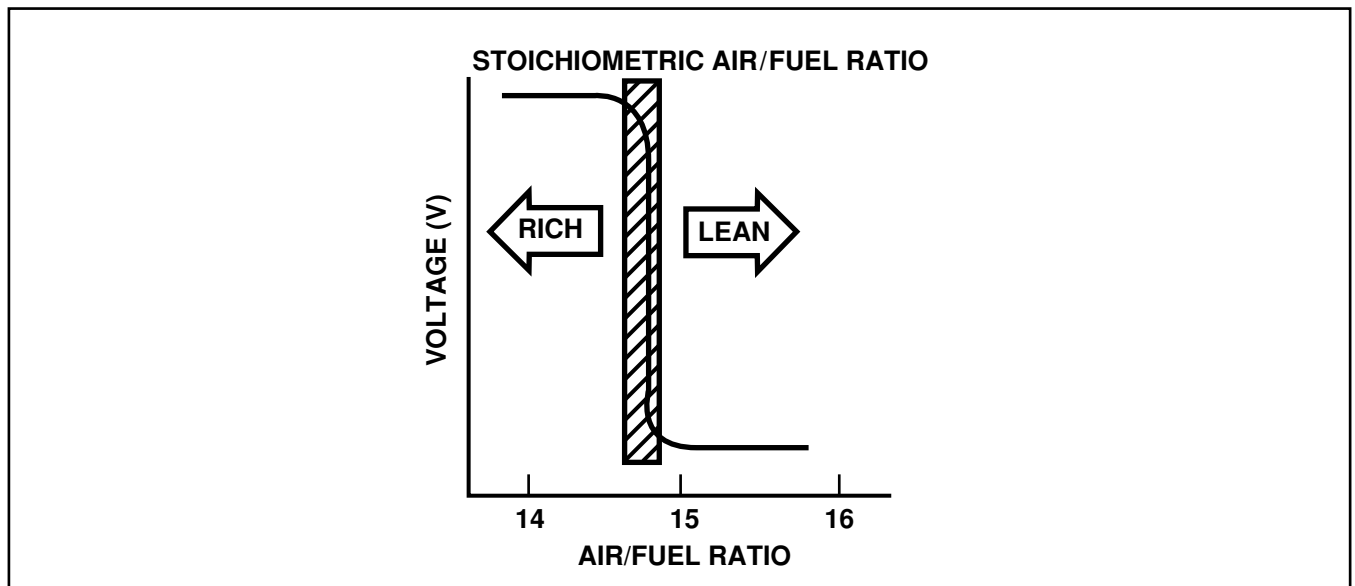

Figure 36 Oxygen Sensor Output

**NOTE:** *These times and temperatures may vary for each engine package.*

The feedback systems begin to operate during closed loop.

# 8.0L – V10 Fuel Injection

## O2 Sensor Electrical Operation

When the O2 Sensor is cold, resistance is extremely high (infinite). As the sensor heats up, two things happen. First, the resistance of the sensors drops. Second, once it heats to a certain temperature, above 660° F, the sensor becomes a galvanic battery, actually creating a voltage output.

On California BR packages and Viper the PCM must be able to power up the heaters, read an input voltage and diagnose the circuit, and the operation of the sensors. To be able to do all this, the PCM uses a 5-volt diagnostic circuit (fig. 33). On a cold start, the PCM sends out 5 volts to the O2 Sensor. As the sensor heats up, resistance decreases through it. As the resistance decreases, the 5 volts should drop. After a short time delay, the PCM measures how long it takes to move from 4 volts to 3 volts. If the voltage drops to a predetermined level then the PCM knows that the heater and sensor are operating correctly. If the voltage goes too low, a short to ground will be indicated.

To detect a short to B+, the PCM waits until the O2 Sensor should be putting out a voltage between .5 and 1.0 volt. If the PCM reads a voltage of 1.5 volts or higher from the sensor, a shorted high fault will be set.

## O2 Sensor Diagnostics

- O2 Sensor shorted to ground (low). At a cold start, BTS and ECT within 27°, ECT below 147°F, if O2S voltage is below 0.156 volt, the fault is set in one trip.
- O2 Sensor shorted to voltage (high) is set with the engine running, ECT has been above 176° for 4 minutes and the O2 Sensor voltage is above 1.5 volts. The upstream sensor fault will set in one trip. However, the downstream sensor takes two trips to set the fault.
- There are also tests required for OBD II. Refer to OBD II section for test descriptions.

# 8.0L - V10 Fuel Injection

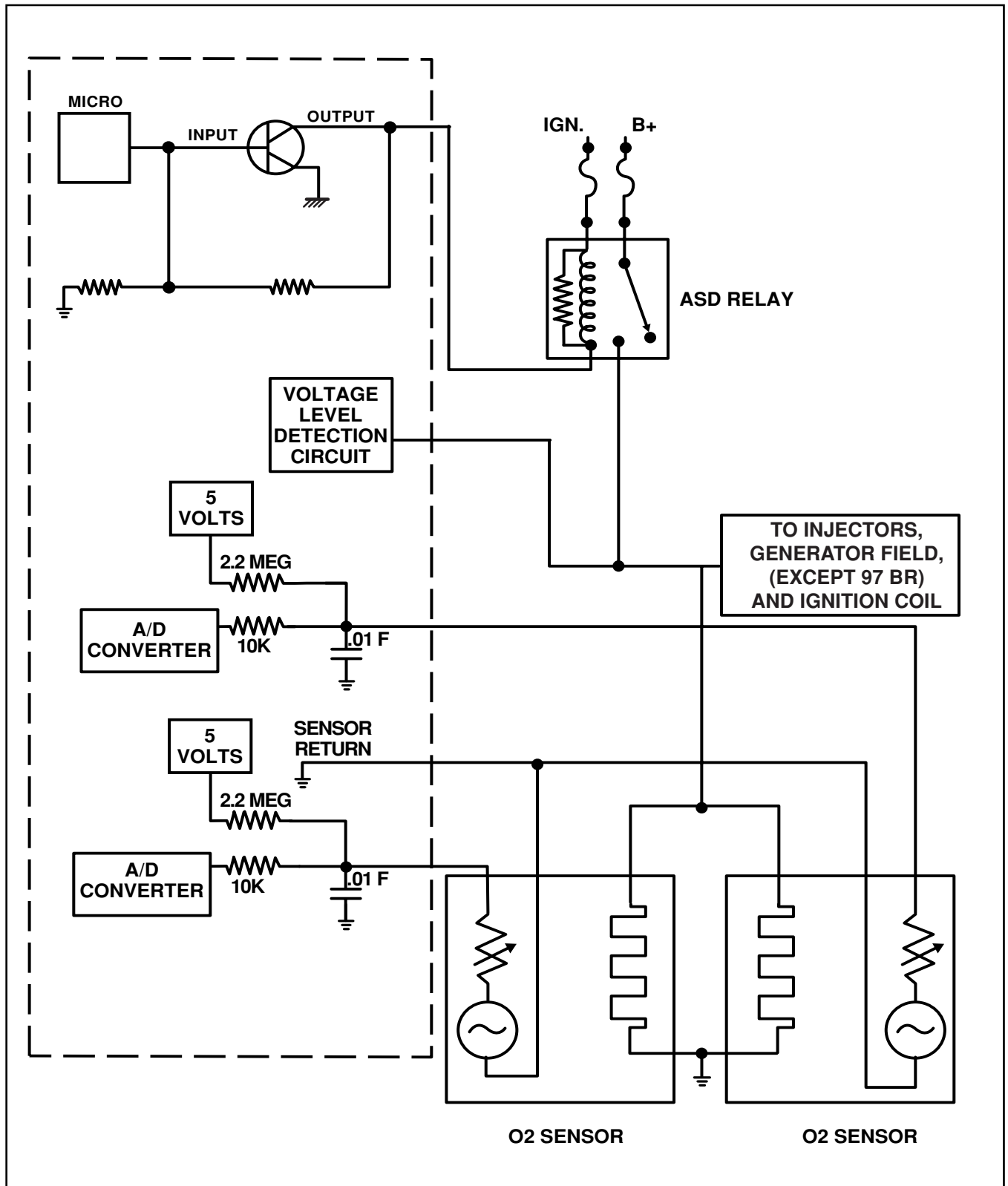

Figure 35 Typical O<sub>2</sub> Sensor Circuit

# 8.0L – V10 Fuel Injection

## ACTIVITY 8 – UPSTREAM O2 SENSOR

Have the instructor assign you a BR or SR vehicle. Use the Service Manual and DRB III to assist in answering the following questions.

1. With a cold engine, open the O2 Sensor signal switch on the breakout box. Using a DRB III, what is the voltage on the PCM side of the circuit? \_\_\_\_\_  
What is the voltage on the O2 Sensor side? \_\_\_\_\_
2. Connect a jumper wire from the PCM side of the switch to your hand. With your other hand, touch the positive battery terminal. What voltage does the DRB III indicate? \_\_\_\_\_
3. Using the DRB III, perform the O2 Sensor heater test. How long did it take for the voltage to begin dropping? \_\_\_\_\_
4. How long did it take for the voltage to reach single digits? \_\_\_\_\_

# 8.0L – V10 Fuel Injection

## Downstream O2 Sensor

As mentioned previously, the downstream O2 Sensor can have two functions. One is to measure catalyst efficiency. This is an OBD II requirement. Briefly, the oxygen content of the exhaust gases leaving the converter has significantly less fluctuation than at the inlet if the converter is working properly. The PCM compares the upstream and downstream O2 Sensor switch rates under specific operating conditions to determine if the catalyst is functioning properly. Refer to the OBD II Training Course for more information.

## BR (Medium Duty) OBD II Vehicles

Another function that is new for 1996 model-year vehicles equipped with JTEC PCMs is that the downstream O2 Sensor input is used to maintain the 14.7:1 Air/Fuel (A/F) ratio. Variations in engines, exhaust systems and catalytic converters may cause this ratio to be less than ideal for a particular catalyst and engine. To help maintain the catalyst operating at maximum efficiency, the PCM will fine tune the A/F ratio entering the catalyst, based upon the oxygen content leaving the catalyst. This is accomplished by modifying the upstream O2 Sensor voltage goal. In the past, this goal was a preprogrammed fixed value, based on where the catalyst was believed to operate most efficiently. With the new downstream O2 Sensor fuel control, the upstream O2 goal is moved up and down, within the window of operation of the O2 Sensor. If the oxygen content leaving the catalyst is too lean (excess oxygen), the PCM will move the upstream O2 goal up, which will increase fuel in the mixture, causing less oxygen to be left over. Conversely, if the oxygen content leaving the catalyst is too rich (not enough oxygen), the PCM will move the upstream O2 goal down, which will remove fuel from the mixture, causing more oxygen to be left over.

This function only occurs during cruise mode operation.

## OBD II

There are several OBD II tests performed by and on the O2 Sensors. A brief description of each follows.

### Catalyst Monitor

The downstream O2 Sensor measures the content of the O2 passing through the catalytic converter. Normally, the downstream O2 Sensor switch rate is extremely slow, compared to that of the upstream sensor rate. As the converter deteriorates, the O2 Sensor switch rate increases. The PCM can compare the signals produced by the upstream and the downstream O2 Sensors to determine the operating efficiency of the catalyst.

### O2 Monitor

Even though an O2 Sensor may be switching and not exceeding the fault thresholds, it must switch with a certain frequency to allow the PCM enough time to make correction before emissions are exceeded. When certain conditions are met (at idle), the PCM checks the switch rate of the O2 Sensor. It looks for how fast it switches, as well as how many times it switches, within a calibrated time. As part of OBD II, the PCM monitors the switching frequency, under specific conditions and will set a fault if the sensor becomes slow or lazy. Refer to the OBD II course for more information.



# 8.0L – V10 Fuel Injection

## O2 Sensor Heater Monitor

The O2 Sensor heater allows the O2 Sensor to reach operating temperature sooner after start-up. It is also necessary because prolonged idle conditions cannot maintain O2 Sensor temperature. If these fail to function, vehicle emissions can increase under certain conditions. On Board Diagnostics II requires monitoring these heaters for proper operation.

If certain conditions have been met at key-on, a test is performed. The heater element itself is not tested. The resistance in oxygen sensor output circuits is tested to determine (infer) heater operation. The resistance is normally between 100 ohms and 4.5 megohms. When oxygen sensor temperature increases, the resistance in the internal circuit decreases. The PCM sends a five-volt signal through the oxygen sensors to monitor this circuit. As temperature increases, resistance decreases and the PCM detects a lower voltage at the reference signal.

The test is performed if the ECT is less than 147°F and ECT and BTS are within 27°F of one another. The PCM measures how long it takes for the voltage to change from above 4 volts to less than 3 volts.

## ADAPTIVE MEMORIES

### Short-Term Adaptive Memory

As mentioned earlier, when the fuel system goes into closed-loop operation, two adaptive memory systems begin to operate. The first system that becomes functional is called short-term memory or short-term correction (fig. 37). This system corrects fuel delivery in direct proportion to the readings from the upstream O2 Sensor. In other words, as the Air/Fuel (AF) mixture changes, the O2 Sensor voltage tells the PCM that the AF ratio contains either more or less oxygen. The PCM then begins either to add or remove fuel until the O2 Sensor reaches its switch point. When the switch point is reached, short-term correction begins with a quick change (kicks). Then it ramps slowly, until the O2 Sensor output voltage indicates the switch point in the opposite direction. Short-term adaptive memory will keep increasing or decreasing injector pulse width, based upon the O2 Sensor input. The maximum range of authority for short-term memory is  $\pm 33\%$  of base pulse width.

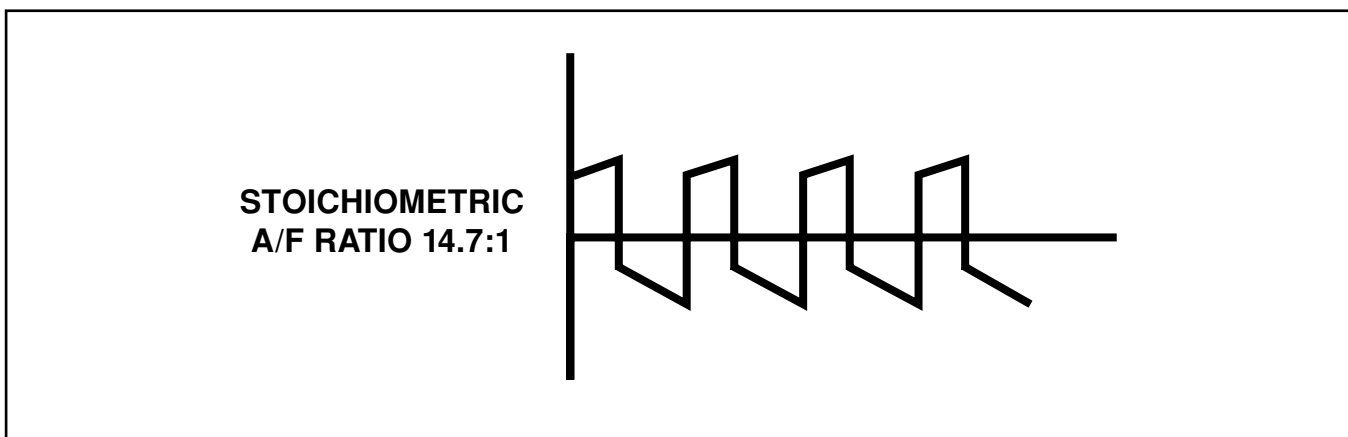

Figure 37 Short-Term Fuel Compensation

# 8.0L – V10 Fuel Injection

For example, if there is a low fuel-pressure problem, the O2 Sensor will start moving toward zero volt, lean mixture (excess oxygen). Short-term fuel correction will begin to add fuel and continue to add (up to 33% of total pulse width), until the O2 Sensor begins switching again.

The PCM's goal is to keep the O2 Sensor switching around the goal voltage.

## Long-Term Adaptive Memory

The second system is called Long-Term Adaptive Memory (fig. 38). In order to maintain correct emission throughout all operating ranges of the engine, it was decided that a cell structure, based on load and engine rpm, should be used (Table 3). There are up to 22 cells. Two are used only during idle, based upon TPS and Park/Neutral switch inputs. There may be another two cells used for deceleration, based on TPS, engine rpm and vehicle speed. The other 17 cells represent a manifold pressure and an rpm range. Each of these cells are a specific MAP voltage range. The values shown in Table 3 are an example only. These values are calibrated for each powertrain package. As the engine enters one of these cells, the PCM looks at the amount of short-term correction being used. Because the goal is to keep short-term at zero (O2 Sensor switching at 0.5 volt), long-term will update in the same direction as short-term correction was moving to bring the short-term back to zero. Once short-term is back at zero, the long-term correction factor will be stored in memory.

	----- Open Throttle -----						Decel	Idle
RPM								
1505-3000*	2	5	8	11	14	17		
1217-1504	1	4	7	10	13	16	19	D/R 21
0-1216	0	3	6	9	12	15	18	P/N 20
MAP	263		346	445	541	630		

	----- Open Throttle -----						Decel	Idle
RPM								
1121-2900*	2	5	8	11	14	17		
897-1120	1	4	7	10	13	16	19	21
0-896	0	3	6	9	12	15	18	20
MAP	247		321	395	470	544		

\* Long term is used up to RPM limiter, however, it is not updated above the approximate rpm shown.

**NOTE: The 8.0L engine has dual adaptive memories. This means that there are 22 memory cells for each cylinder bank, creating separate pulse width calculations for each side.**

Table 3 Adaptive Memory Cells

## 8.0L - V10 Fuel Injection

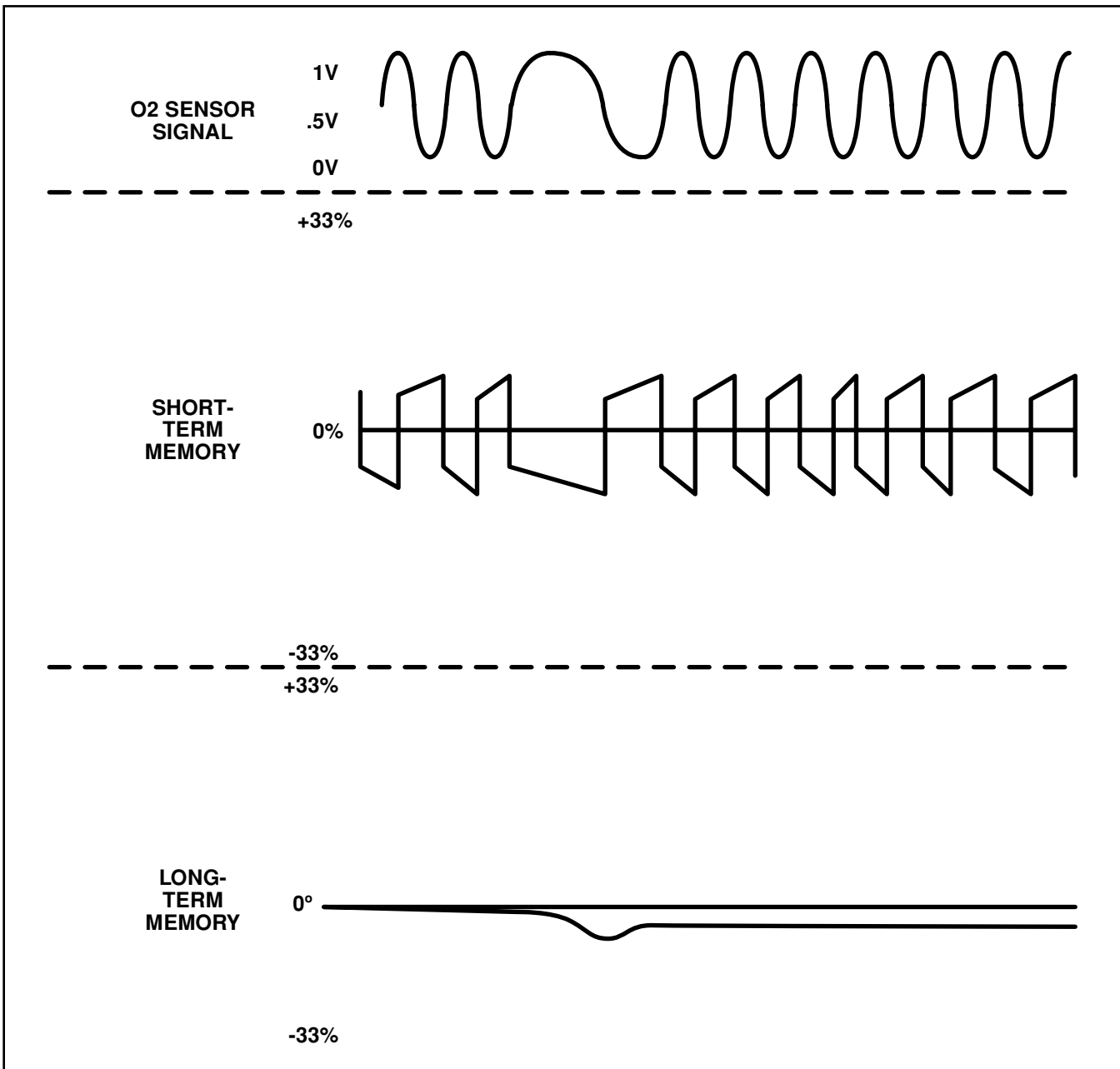

Figure 38 Long-Term Fuel Compensation

The values stored in long-term adaptive memory are used for all operating conditions, including open loop. However, updating long-term memory occurs after the engine has exceeded approximately 170°F, with fuel control in closed loop and two minutes of engine run time. This is done to prevent any transitional temperature or start-up compensations from corrupting long-term fuel correction.

## 8.0L – V10 Fuel Injection

Using the low fuel-pressure example, the PCM had stored a fuel correction in long-term memory to compensate for the low fuel pressure. At key-on, cold engine, when the PCM does its pulse-width calculation, the long-term factor will be added, because it knows there was a problem in that cell. Long-term adaptive can change the pulse width by as much as 33%, which means it can correct for all of short-term. It is possible to have a problem that would drive long-term to 33% and short-term to another 33% for a total change of 66%, away from base pulse-width calculation.

Short- and long-term is expressed as a percentage of pulse-width change.

### Purge-Free Cells

Purge-free memory cells are used to identify the fuel vapor content of the evaporative canister. Since the evaporative canister is not purged 100% of the time, the PCM stores information about its vapor content in a memory cell. The construction of purge-free cells is similar to that of certain purge-normal cells. For example: the 8.0L BR purge-free cells have the same rpm and MAP structure of cells 4, 5, 8, and 20. The 8.0L SR purge-free cells have the same rpm and MAP structure of cells 7, 8, 11 and 20.

The purge-free cells can be monitored by the DRB III scan tool. They are represented on the BR by Purge-Free Cell “PF4, PF5, PF8, PF20.” For SR, the Purge-Free Cells “PF7, PF8, PF11 and PF20.” The only difference between the purge-free cells and normal adaptive cells is that in purge-free, the purge is turned off completely. This gives the PCM the ability to compare purge and purge-free operation.

### Purge Corruption Reset Feature

At a cold start (ECT and BTS within 20° of each other), the PCM compares the value of the purge-free cell to the value in long-term memory (fig. 39). If the difference is too large, the PCM will replace the value in long-term memory with the corresponding purge-free cell value. The cells that do not have corresponding purge-free will be replaced with the largest purge-free value. If a cell is already higher than the highest purge-free, it will not be changed.

# 8.0L - V10 Fuel Injection

## LONG-TERM ADAPTIVE MEMORY

<del>-6</del> +1 C2	<del>-31</del> +1 C5	<del>-3</del> +1 C8	<del>-5</del> +1 C11	+5 C14	+1 C17		
<del>-4</del> +1 C1	<del>-32</del> -3 C4	<del>-5</del> +1 C7	<del>-0</del> +1 C10	<del>-1</del> +1 C13	<del>-1</del> +1 C16	<del>-1</del> +1 C19	<del>-24</del> +1 C21
<del>-4</del> +1 C0	<del>-32</del> +1 C3	<del>-30</del> +1 C6	<del>-3</del> +1 C9	<del>-1</del> +1 C12	<del>-0</del> +1 C15	+2 C18	<del>-27</del> -4 C20

-3 PF4	+1 PF5	+1 PF8	-4 PF20
-----------	-----------	-----------	------------

RPM	----- Open Throttle -----						Decel	Idle
1505-3000	2	5	8	11	14	17		
1217-1504	1	4	7	10	13	16	19	21
0-1216	0	3	6	9	12	15	18	20
MAP	10.35"	13.62"	17.52"	21.30"	24.80"			

Figure 39 Purge Corruption Reset

### DRB III Display

The DRB III can be used to display both of these systems. The long-term memory cells are shown with the long-term correction factor in each cell. The short-term correction is always changing and is displayed above the long-term memory cells. The DRB III displays long-term adaptive memory cells similar to Table 3.

# 8.0L – V10 Fuel Injection

## ACTIVITY 9 – FUEL ADAPTIVE MEMORY

### Instructions

Have the instructor assign you to a vehicle. Using the appropriate Service Manual or Powertrain Diagnostic Procedures Manual as reference material, answer the following questions.

1. With the engine running, use the simulator to reduce fuel pressure. What happened to adaptive memories? \_\_\_\_\_

Restore fuel pressure.

2. Using the simulator, change ECT both hotter and colder. What happened to adaptive memories? \_\_\_\_\_  
Why? \_\_\_\_\_
3. Using the simulator, change MAP both up and down. What happened to adaptive memories? \_\_\_\_\_  
Why? \_\_\_\_\_
4. Using the simulator, change IAT voltage both up and down. What happened to adaptive memories? \_\_\_\_\_  
Why? \_\_\_\_\_
5. Using the simulator, change upstream O2 voltage both up and down. What happened to adaptive memories? \_\_\_\_\_  
Why? \_\_\_\_\_
6. Pull off a spark plug wire. What happened to adaptive memories? \_\_\_\_\_  
\_\_\_\_\_
7. Using the simulator, with the engine in a cruise mode, change downstream O2 voltage and watch upstream O2 goal voltage. What happened to the goal voltage? \_\_\_\_\_  
Why? \_\_\_\_\_

## 8.0L - V10 Fuel Injection

### PARK/NEUTRAL SWITCH (AUTO TRANSMISSION ONLY)

The Park/Neutral switch is located on the transmission housing. The Park/Neutral switch uses the same contacts as the starter relay, and provides a path to ground when the vehicle is shifted into PARK or NEUTRAL.

The PCM delivers 12 volts to the center terminal of the Park/Neutral switch (fig. 40). When the gear shift lever is moved to either the PARK or the NEUTRAL position, the PCM receives a ground signal from the Park/Neutral switch. With the shift lever positioned in DRIVE or REVERSE, the Park/Neutral switch contacts open, causing the signal to the PCM to increase.

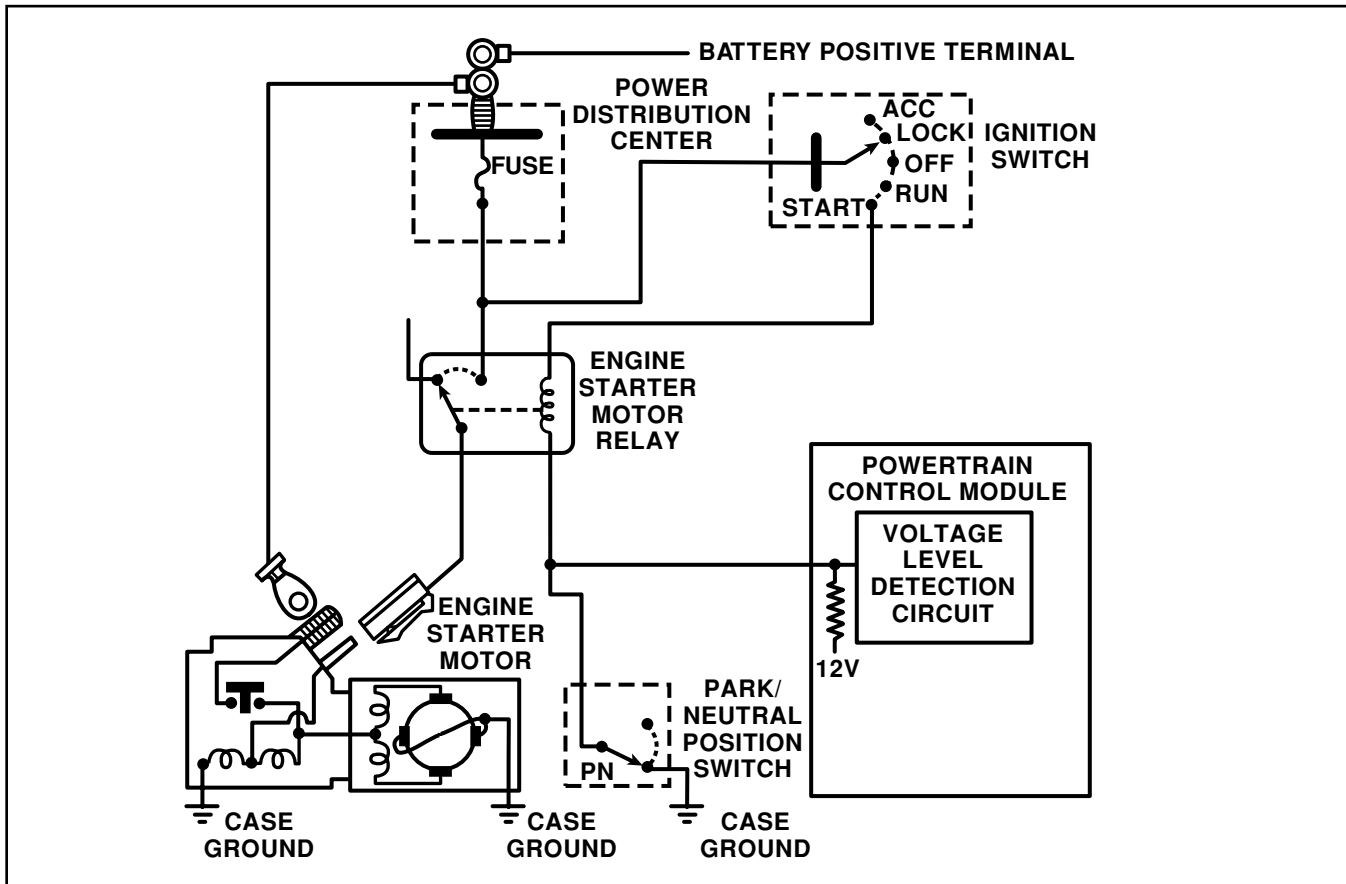

Figure 40 Park/Neutral Switch Circuit

The Park/Neutral switch sends a signal to the PCM to identify gear engagement. From the time that the shift lever is moved into a forward or reverse gear, until the transmission is fully engaged into a gear, may be several milliseconds. When the Park/Neutral switch changes identifying when the transmission is shifted into gear, the PCM increases the IAC steps before the transmission clutch engages. This prevents the RPM from dropping as the transmission engages and puts a load on the engine.

## **8.0L – V10 Fuel Injection**

The PCM uses information from the Park/Neutral (P/N) switch to calculate the following:

- Spark-advance programs (idle control).
- Injector pulse-width programs (long-term memory cells 20 and 21).
- Speed-control disengagement.
- Target idle.
- Anticipation of the load increase (IAC and timing).
- There are no OBD II diagnostics performed in Park/Neutral.

### **OBD II Rationality Test**

There is an OBD II rationality fault for the P/N switch. If the PCM sees vehicle movement based on vehicle speed, MAP, TPS, engine rpm, and the wrong P/N state is indicated, a fault will be set. The PCM also checks for indication of P/N during start and will set a fault if the vehicle is started in Drive.



# 8.0L - V10 Fuel Injection

## BRAKE SWITCH

When the brakes are applied, the brake switch provides an input to the PCM to disengage the speed control. It is also used to influence transmission torque-converter clutch disengagement.

The brake switch is equipped with three sets of contacts, one normally open and the other two normally closed (brakes disengaged). The PCM sends a 12-volt signal to one of the normally closed contacts in the brake switch, which is connected to a ground (fig. 41). With the contacts closed, the 12-volt signal is pulled to ground, causing the signal to go low. The low-voltage signal, monitored by the PCM, indicates that the brakes are not applied. When the brakes are applied, the contacts open, causing the PCM's output voltage to go high, disengaging the speed control, if so equipped.

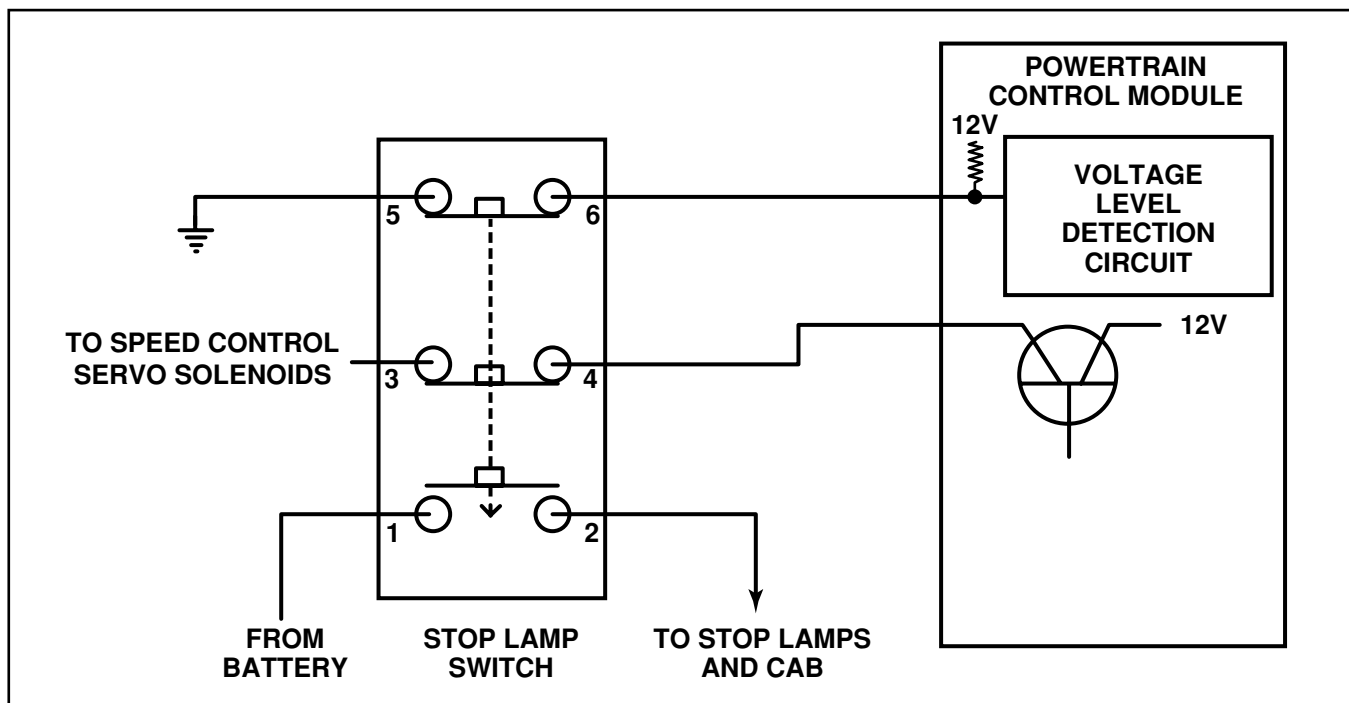

Figure 41 Brake Switch Circuit

If the brake switch circuit is pulled high, with or without brake pedal application:

- speed control will not work.
- There will be no torque converter lockup on vehicles equipped with an automatic transmission.

## Clutch Pedal Position Switch

If the vehicle is equipped with a manual transmission, it has a clutch pedal position switch installed in series between the ignition switch and the coil battery terminal of the starter relay. This normally open switch prevents the starter relay from being energized unless the clutch pedal is depressed. This prevents starter operation while the clutch disc and flywheel are engaged. The starter relay is always grounded on vehicles with manual transmissions.

# 8.0L - V10 Fuel Injection

## Component Location

The brake switch is located rearward of the brake pedal and is attached to the brake pedal sled (fig. 42).

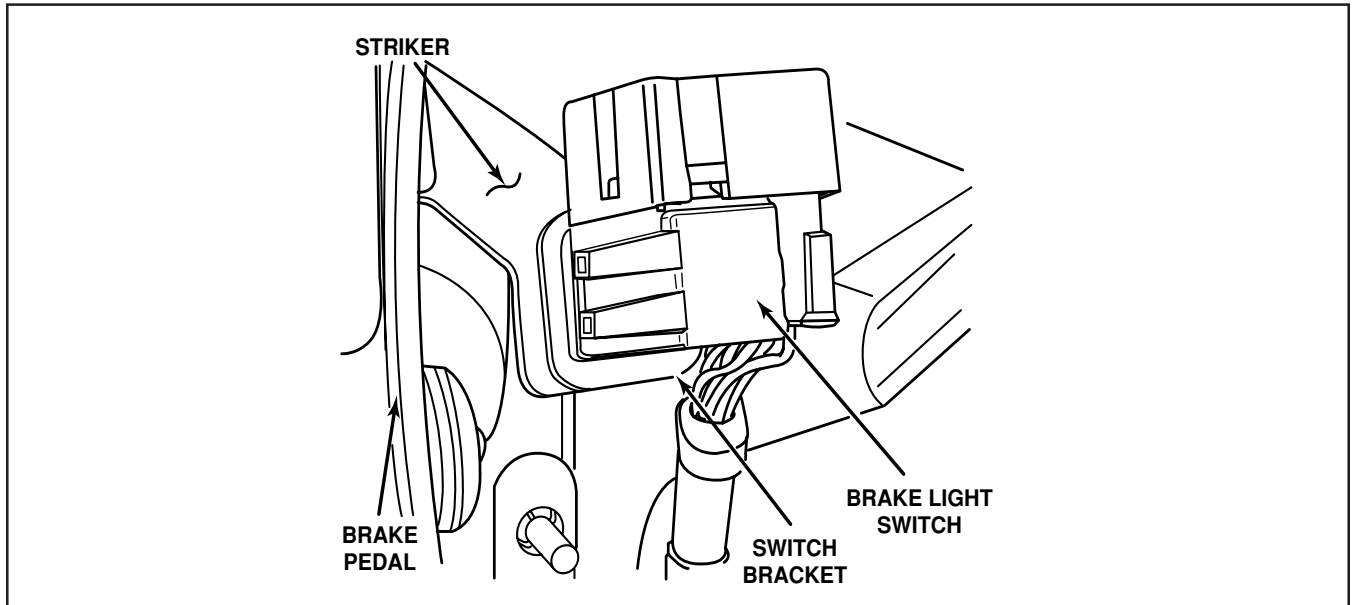

Figure 42 Vehicle Speed Sensor Circuit

# 8.0L – V10 Fuel Injection

## VEHICLE SPEED SENSOR (VSS)

Vehicle speed is transmitted to the PCM via the vehicle Speed Sensor, which is located in the transmission extension housing. The PCM requires the VSS to control the following programs:

- Speed control
- IAC motor (during deceleration)
- Injection pulse width (during deceleration)
- OBD II diagnostics
- PCM mileage EEPROM
- Road speed shutdown
- Speedometer/Odometer

**NOTE:** Road speed shutdown is the PCM shutting off fuel injectors above a preset vehicle speed and rpm.

The VSS is a Hall-effect sensor. This sensor is mechanically driven by a pinion gear that is located on the output shaft of the transmission for 2-wheel drive vehicles, and on the output shaft of the transfer case for 4-wheel drive vehicles. The Hall-effect sensor switches a five-volt signal sent from the PCM from a ground to an open circuit at a rate of eight pulses per revolution. When the PCM counts a specific number of pulses (8,000 for BR, 10,000 for SR), it assumes it has traveled one mile.

Like all Hall-effect sensors, the sensor electronics need a power source. This power source, the secondary 5-volt supply, is provided by the PCM (fig. 43).

## Vehicle-Speed Sensor Diagnostics

If the ECT indicates a warm engine while MAP and engine indicate vehicle movement and there is no VSS signal, a rationality fault will be set.

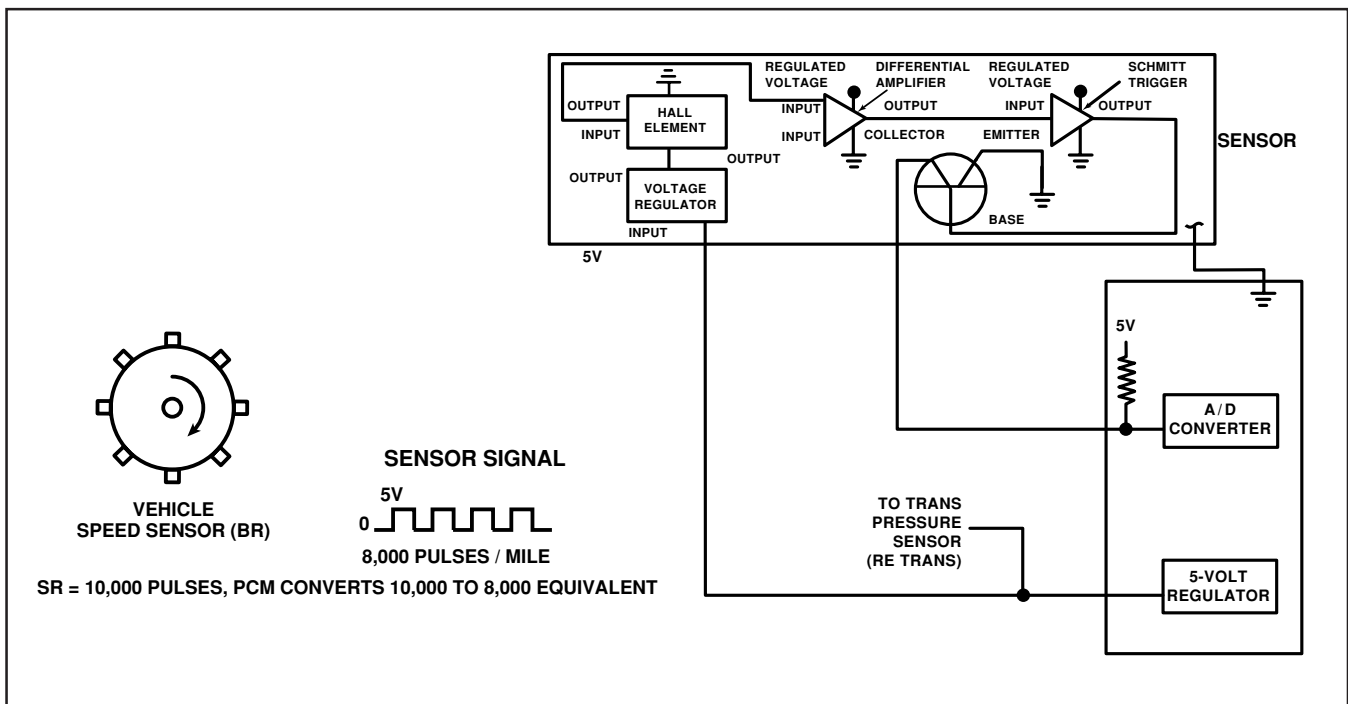

Figure 43 Vehicle Speed Sensor Circuit

# 8.0L - V10 Fuel Injection

## FUEL-LEVEL SENSOR INPUT

Fuel level is an input that is used as a disabler for OBD II. For the 1997 BR and 1996-97 SR vehicles, the fuel level is input directly to the PCM (fig. 44).

On these vehicles, the 12 volts is supplied from the dash gauge to the fuel level sensor and the PCM. The PCM measures the voltage drop across the resistor of the sensor.

On the 1996 BR there is no fuel level input to the PCM.

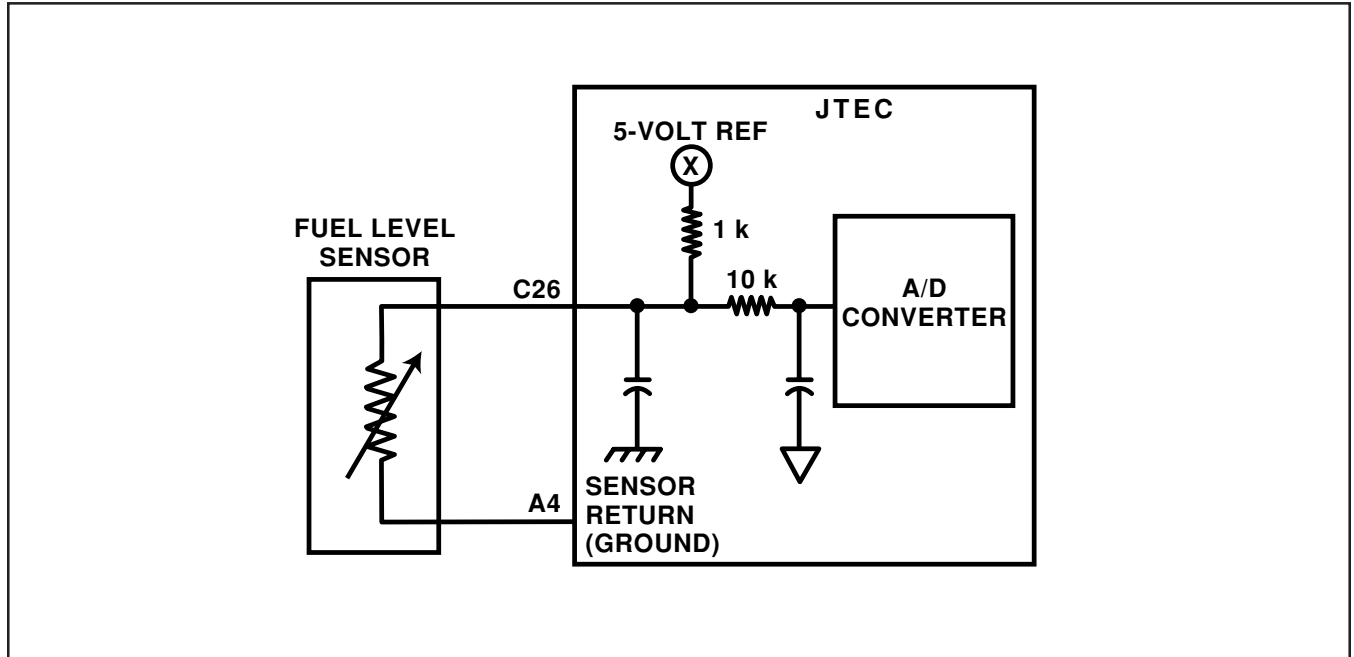

Figure 44 Fuel-Level Sensor Circuits

# 8.0L – V10 Fuel Injection

## BATTERY/AMBIENT TEMPERATURE SENSOR

### BR/96 Coupe/97 Viper

The PCM uses an input from the Battery/Ambient Temperature Sensor (BTS) located on the battery tray (fig. 45) BR. The function of the BTS is to enable control of the generator output, based upon ambient temperature. As temperature increases, the charging rate should decrease (Table 4). As temperature decreases, the charging rate should increase. The PCM maintains the maximum output of the generator by monitoring battery voltage and controlling battery voltage to a range of 13.5-14.7 volts.

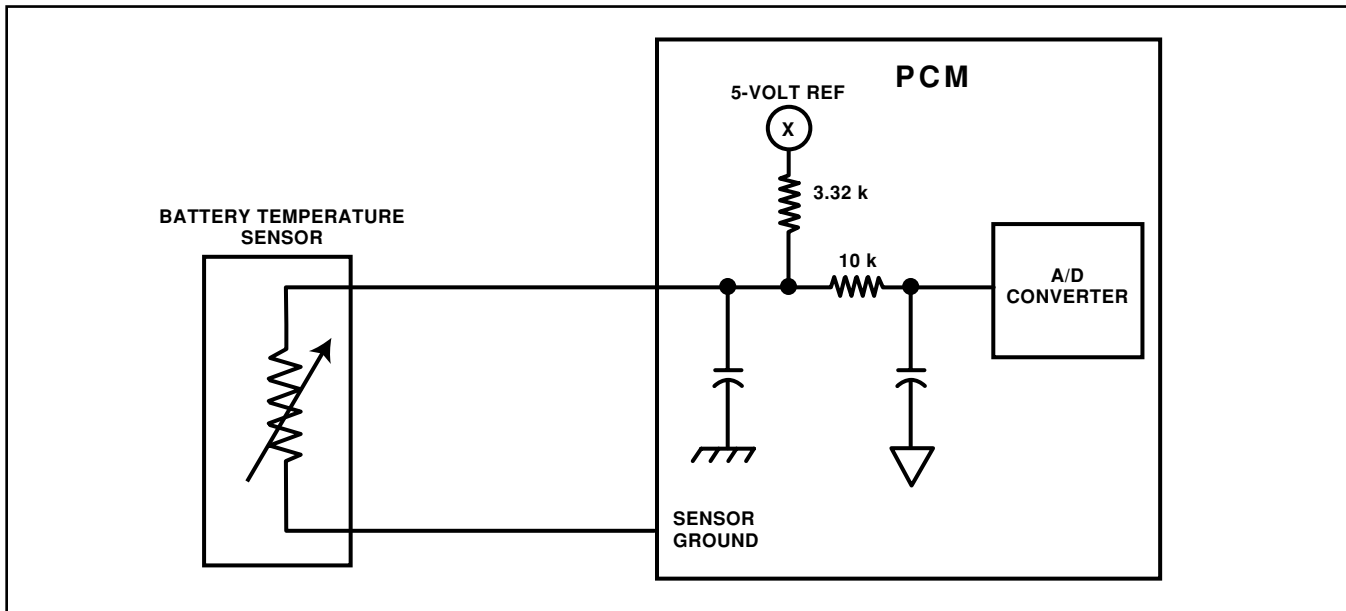

Figure 45 Battery/Ambient Temperature Sensor Circuit

The BTS is also used for OBD II diagnostics. Certain faults and OBD II monitors are either enabled or disabled, depending upon BTS input (for example, disable purge and EGR (if equipped) enable LDP and O<sub>2</sub> heater test). Most OBD II monitors are disabled below 20°F.

If the BTS indicates a voltage that is too high or too low, the PCM sets a DTC. When the DTC is set, the MIL is illuminated and the PCM moves into limp-in mode. In limp-in, the PCM will substitute a preset value. Using this substitute temperature, the PCM changes to a preset target-charging system voltage.

### 1996 Viper Roadster

This vehicle uses an ambient temperature as part of its OBDII diagnostics. The ambient sensor is located behind the front fascia toward the drivers side. Refer to the OBDII training course for more information. The charging system on this vehicle is not controlled by the PCM and therefore a battery temperature sensor is not needed.

# 8.0L – V10 Fuel Injection

Battery Temperature (°F)	Target Charging Rate
-4	15.19 – 14.33
32	14.82 – 13.96
68	14.51 – 13.65
104	14.08 – 13.22
144	13.77 – 13.04

Table 4 Charging Rates

## Battery Temperature Sensor Diagnostics

- Batt Temp Sensor Voltage Low is set if the sensor voltage is below 0.08 volt.
- Batt Temp Sensor Voltage High is set if sensor voltage is above 4.9 volts.

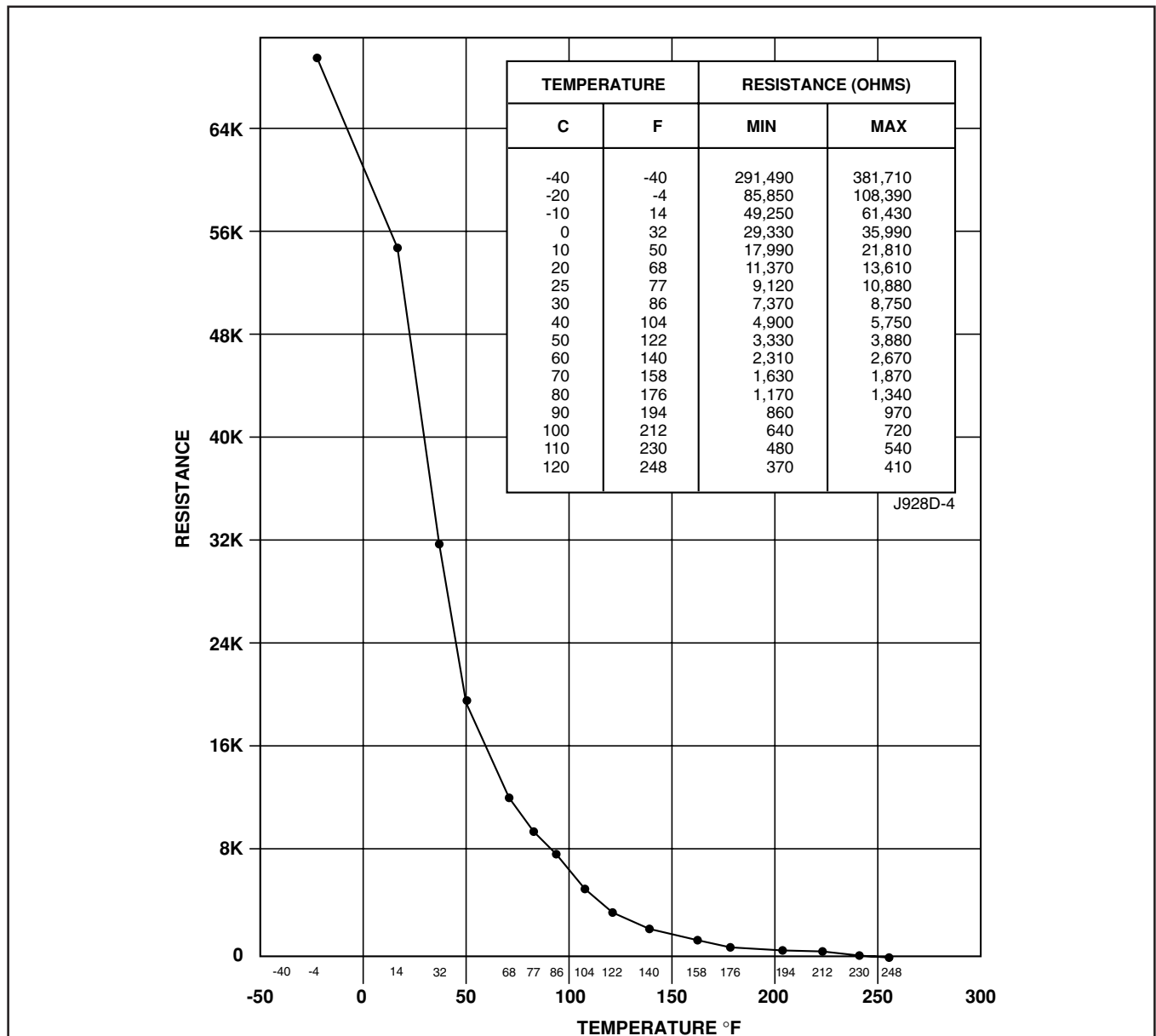

Figure 46 Battery Temperature Sensor — Resistance vs. Temperature

## 8.0L - V10 Fuel Injection

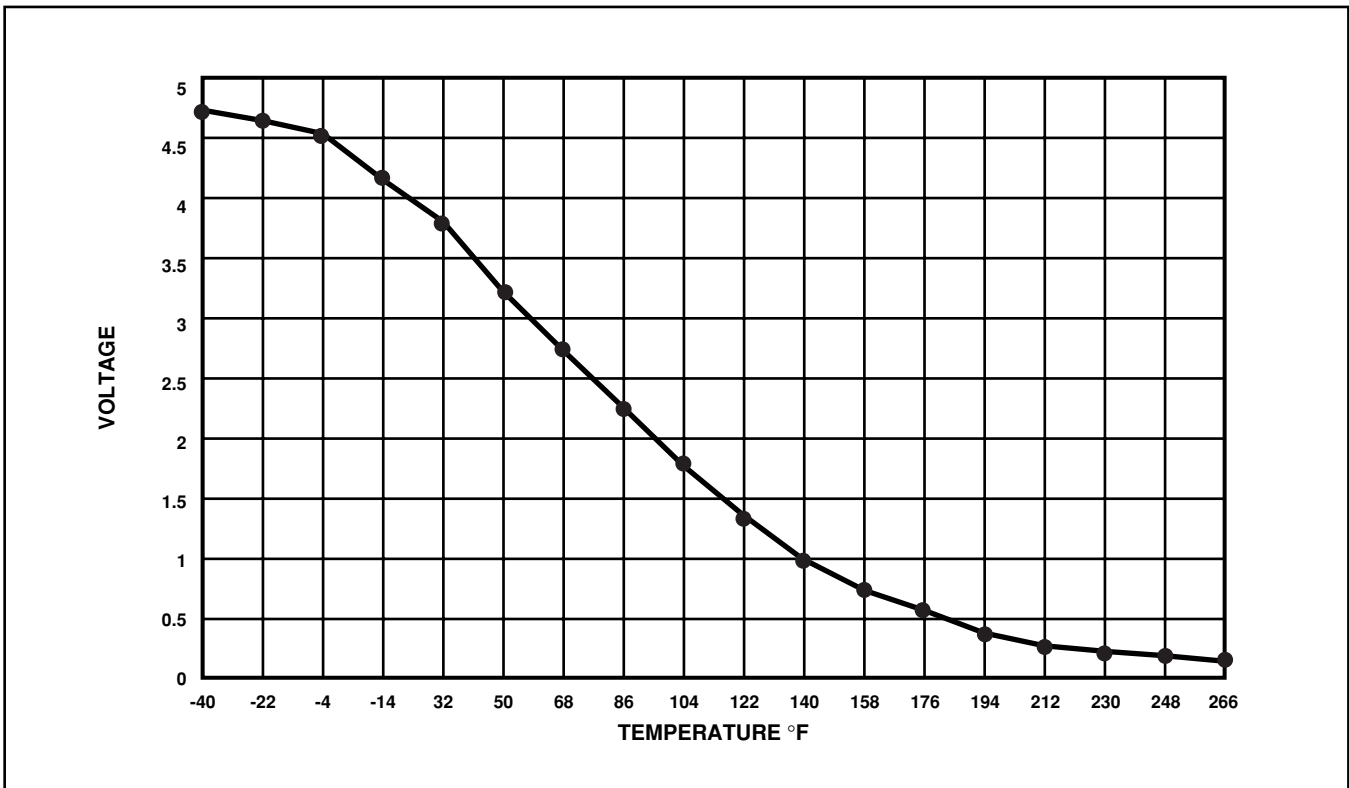

Figure 47 Battery Temperature Sensor — Temperature vs. Voltage

# 8.0L - V10 Fuel Injection

## AIR CONDITIONING SWITCH

When the A/C-heater control switch is moved to an A/C position or the defroster position, the PCM A/C select circuit is pulled low when ground is provided through the dash panel switch (fig. 49). The PCM request circuit is also pulled low if the A/C pressure switches and thermostatic switch (SR only) are closed. Refer to the A/C section for more information.

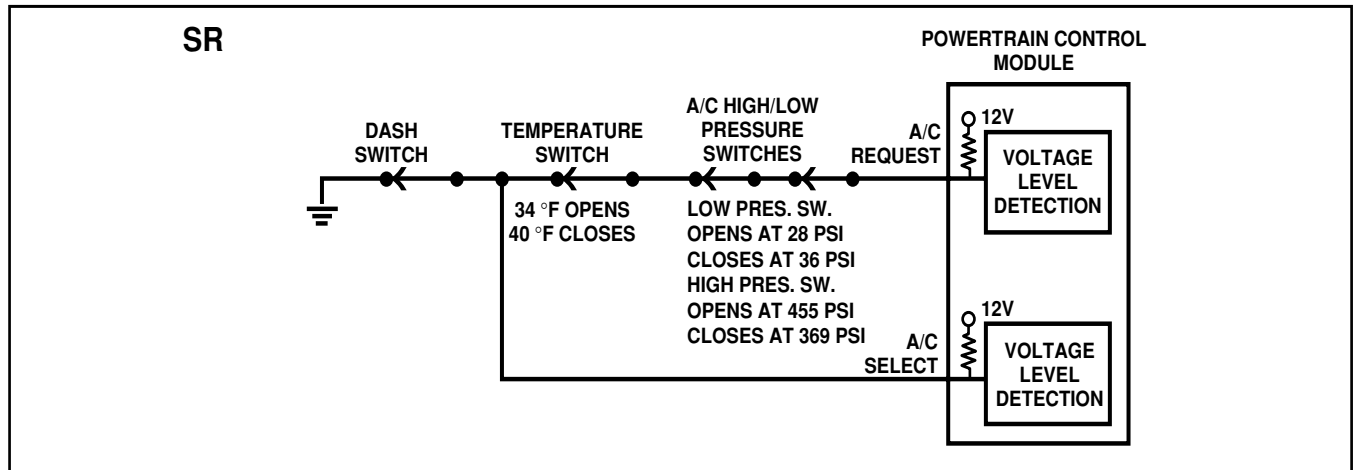

Figure 48 Air Conditioning Switch Circuit (SR)

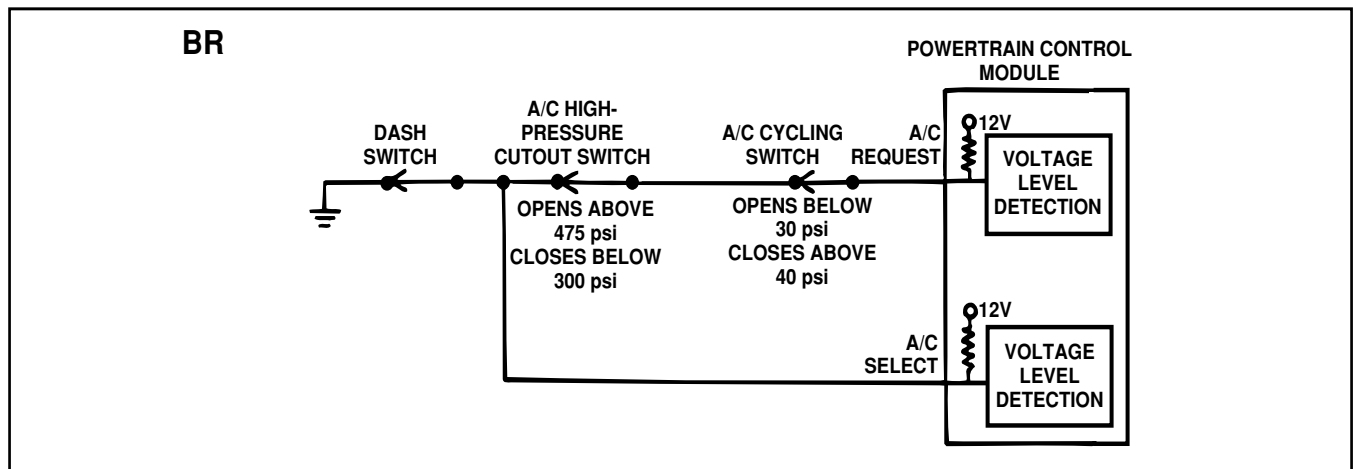

Figure 49 Air Conditioning Switch Circuit (BR)



# 8.0L – V10 Fuel Injection

## **STALL TORQUE MANAGEMENT-BR**

To reduce torque converter stall at high loads and low rpm, the PCM limits engine torque to approximately 225 ft-lb for engine speeds under 2100 at WOT and less than 400-rpm output shaft speed by reducing timing back to 0°.

## **TRANSMISSION-FLUID TEMPERATURE SENSOR-BR**

Transmission fluid temperatures are supplied to the TCM portion of the PCM. The input is used in the shift operation for 4-speed electronic transmissions only. The temperature data is used for:

- Torque converter clutch operation.
- Overdrive shift.
- Low-temperature shift compensation.
- Wide-open-throttle shift strategy.
- Governor-pressure transducer calibration.

## **TRANSMISSION-GOVERNOR PRESSURE SENSOR-BR**

The governor pressure sensor measures output pressure of the governor-pressure solenoid valve. This input is used with 4-speed electronic transmission only. The sensor provides the PCM with the necessary feedback to control the governor-pressure solenoid, which regulates transmission governor pressure.

Refer to the transmission section for more information.

## **TRANSMISSION-OUTPUT SHAFT SPEED SENSOR-BR**

This sensor generates an AC signal to the PCM relating to the speed of the transmission main driveshaft. This input is used with 4-speed electronic transmission only.

Refer to the transmission section for more information.

# 8.0L – V10 Fuel Injection

## ACTIVITY 10 — PCM INPUTS

### VSS

1. Change DRB III to find vehicle speed. With engine running at idle, closed throttle, slowly increase road speed to 60 mph. What happened to engine speed?  
Why? \_\_\_\_\_
2. Open throttle to 3,000 rpm. Slowly increase road speed. At what speed did the road speed shutdown occur? \_\_\_\_\_
3. With vehicle in road speed shutdown, what does injector pulse width display?  
\_\_\_\_\_
4. With road speed at closed throttle 30 mph, what does VSS display on Lab Scope?
5. Change road speed. What happened to display? \_\_\_\_\_
6. Disconnect simulator. Open VSS switch. What does voltage read on both sides of the switch? \_\_\_\_\_

Engine off.

7. Change DRB III to read fuel level. What level is shown? \_\_\_\_\_
8. Change DRB III to read Batt/Ambient Temp Sensor. What does it show for voltage?  
\_\_\_\_\_  
And temperature? \_\_\_\_\_
9. Open switch on BOB. What does DRB III display for voltage? \_\_\_\_\_  
And temperature? \_\_\_\_\_
10. Measure voltage on both sides of switch. What are the readings? \_\_\_\_\_  
And sensor? \_\_\_\_\_

Erase codes when done.

# 8.0L – V10 Fuel Injection

## LESSON 5

### FUEL INJECTION SYSTEM — PCM OUTPUTS

#### SOLENOID AND RELAY CONTROL

Most of the output relays and solenoids are controlled by quad drivers. A quad driver is a single microchip that contains four separate driver circuits that are used for controlling high current output devices.

A voltage divider circuit has been added to diagnose the operation of the driver circuit. This voltage divider is located between the output of the driver and the input command (from microprocessor) to the driver.

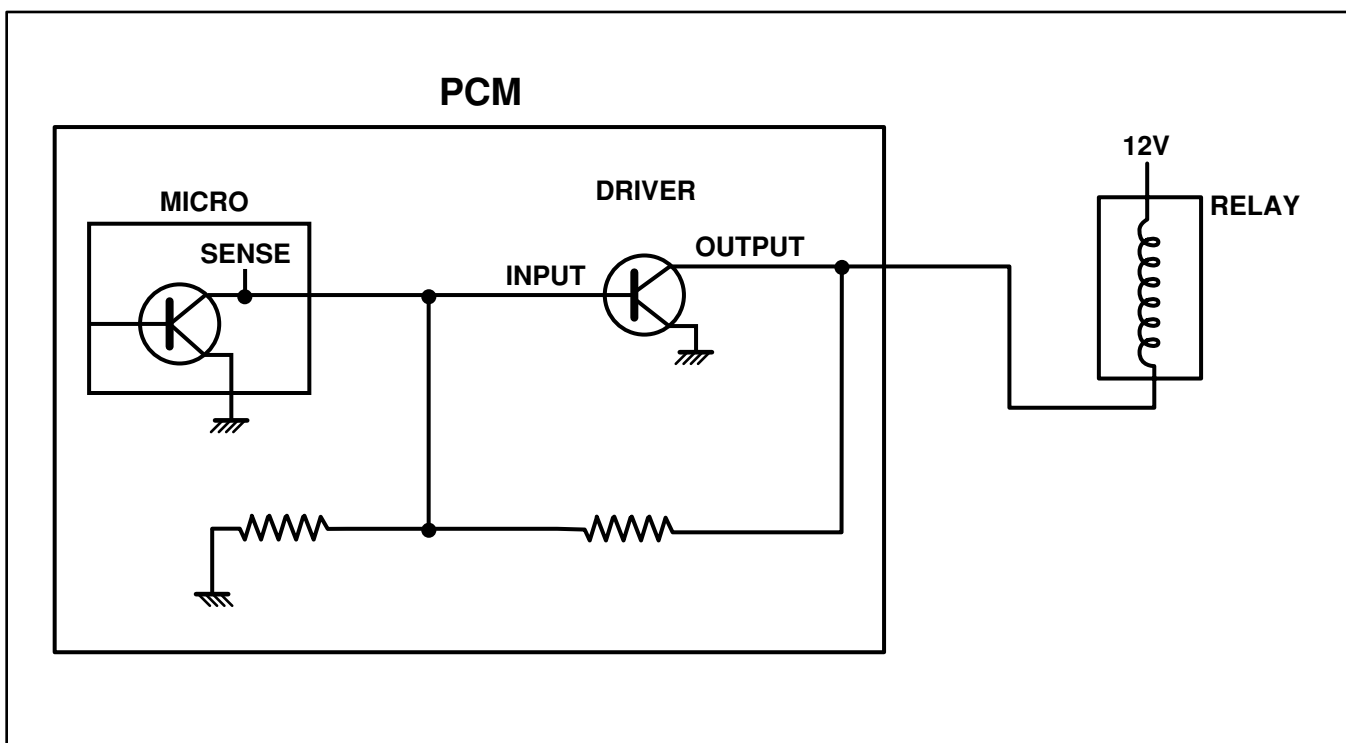

Figure 50 Sense Circuit

There is a sense circuit located at the microprocessor on the input command line to the driver. When the command is OFF, the 12 volts from the relay coil will go through the voltage divider leaving 6 volts at the sense point. Therefore, an OFF command will look for voltage to be high (fig. 50).

When the command is ON, the micro closes a circuit allowing the 6 volts to go to ground. This energizes the driver. When the driver is energized, the 12 volts are allowed to go to ground through the driver. Once this occurs, the voltage at the sense point goes low. Therefore, an ON command will look for voltage to be low.

Because of this design, the PCM is capable of continuous diagnostics, without the need for a request to change state.

When the key is first turned on, some relays and solenoids are actuated very quickly (before engine starts) to verify the circuitry.

## 8.0L – V10 Fuel Injection

Once the key is turned on, the sense point is continuously monitored. If a circuit opens or a short to ground occurs when the requested state is off, a fault will be set. However, if a circuit should open or short to ground when the requested state is ON, this will not be detected until the state is changed to OFF. This is due to the fact that when the state is ON, the circuit is already low, so it is not possible to know that an open has occurred.

**Caution:** *Both diode- and resistor-suppressed relays have been used. If an incorrect relay is used, damage may occur to the relay, circuit or PCM.*

### **AUTOMATIC SHUTDOWN RELAY (ASD)**

When energized, the ASD relay provides power to operate the injectors, ignition coil, generator field (1996 and 1997 Viper) and O2 Sensor heaters (upstream and downstream). It also provides a sense circuit to the PCM for diagnostic purposes. The PCM energizes the ASD:

- Anytime there is a Crankshaft Position sensor signal that exceeds a predetermined value.
- For approximately 1.8 seconds during the initial key-on cycle.

# 8.0L - V10 Fuel Injection

The ASD relay electromagnet is provided with battery voltage from the ignition switch (figs. 51 and 52). The PCM provides the ground.

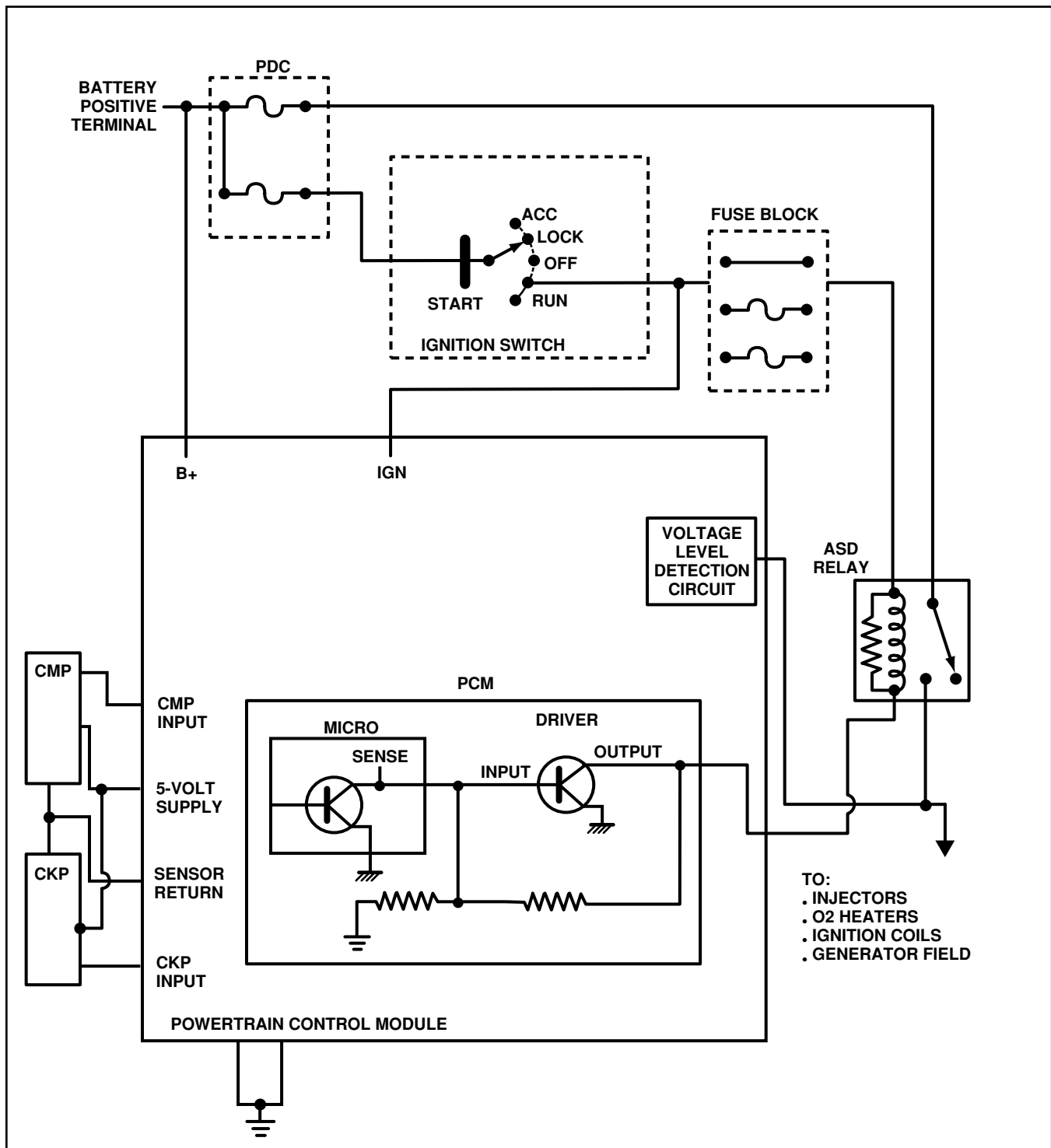

Figure 51 ASD Relay Circuit — Typical '96 and '97 SR

# 8.0L - V10 Fuel Injection

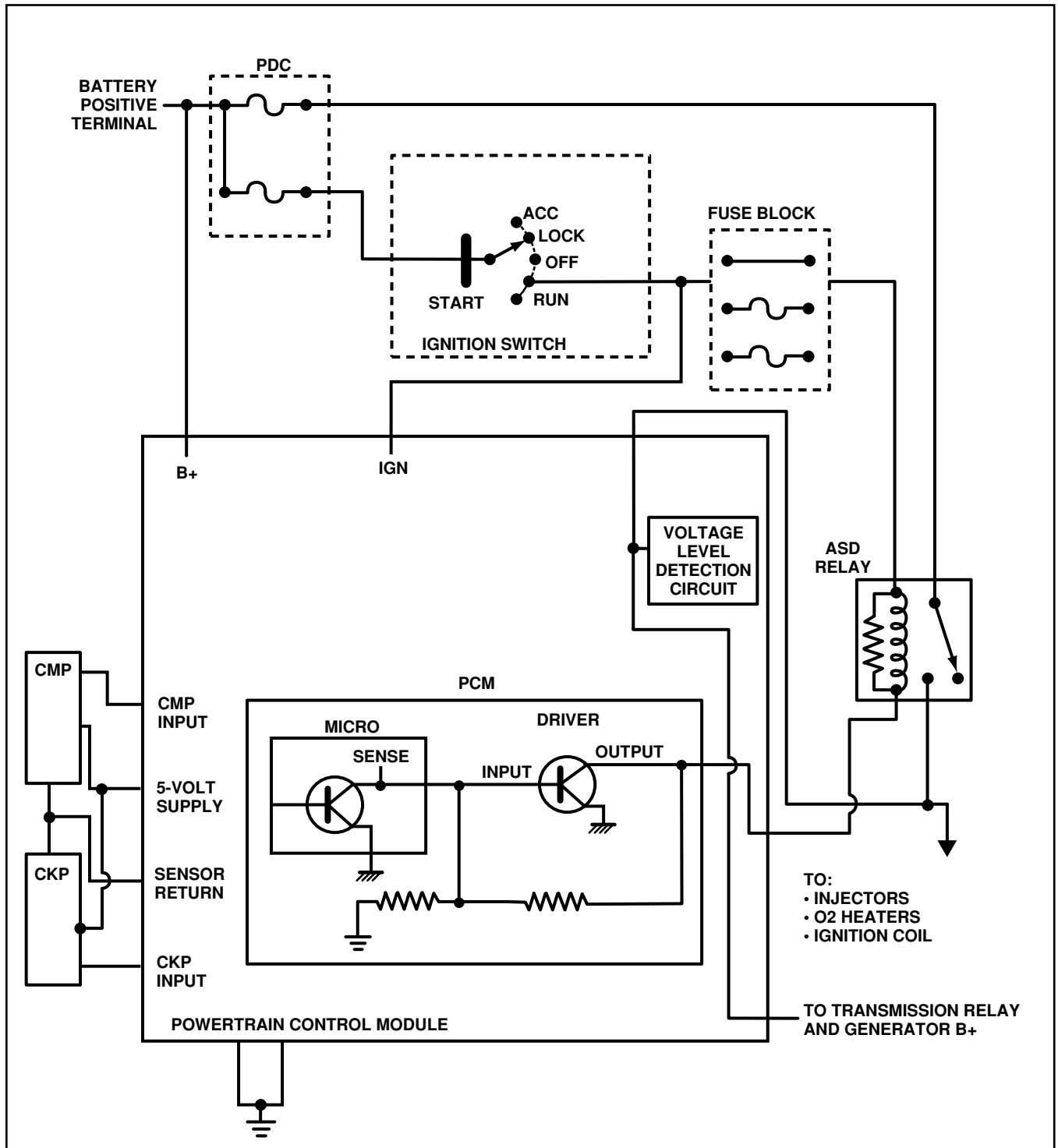

Figure 52 ASD Relay Circuit — 1997 BR

# 8.0L - V10 Fuel Injection

## FUEL PUMP RELAY

The fuel pump relay is energized to provide power to operate the fuel pump under the following conditions:

- For approximately 1.8 seconds during the initial key-on cycle.
- While the CKP sensor is providing an rpm signal that exceeds a predetermined value.

Ignition voltage is provided to the fuel pump relay electromagnet any time the key is in the RUN position (fig. 53). The PCM provides the ground control to energize the relay. Unlike previous Chrysler systems, the fuel pump relay does not provide power to operate the O2 Sensor heaters.

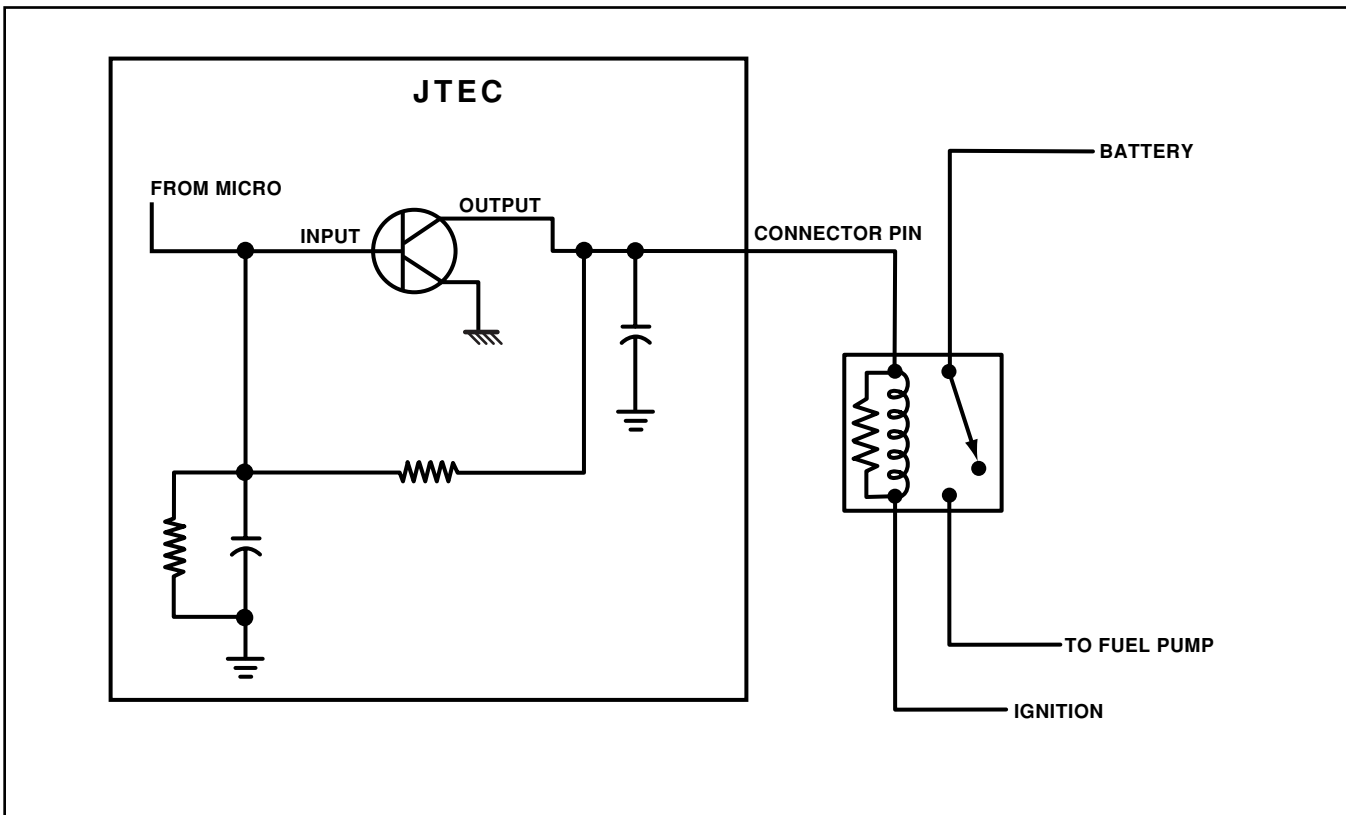

Figure 53 Fuel Pump Relay Circuit

The relay is energized when the key is cycled to RUN in order to prime the fuel rail with liquid fuel, allowing for a quick start-up. Anytime the Crankshaft Position sensor indicates that there is an rpm signal that exceeds a predetermined value, the relay is energized to ensure proper fuel pressure and volume during engine cranking and running conditions. Anytime the Crankshaft Position sensor signal is lost (engine has been shut off, or the sensor indicates no rpm), the fuel pump relay is de-energized.

# 8.0L - V10 Fuel Injection

## FUEL INJECTORS

The PCM provides battery voltage to each injector through the ASD relay (fig. 54). Injector operation is controlled by a ground path, provided for each injector by the PCM. Injector on-time (pulse width) is variable, and is determined by the duration of the ground path provided.

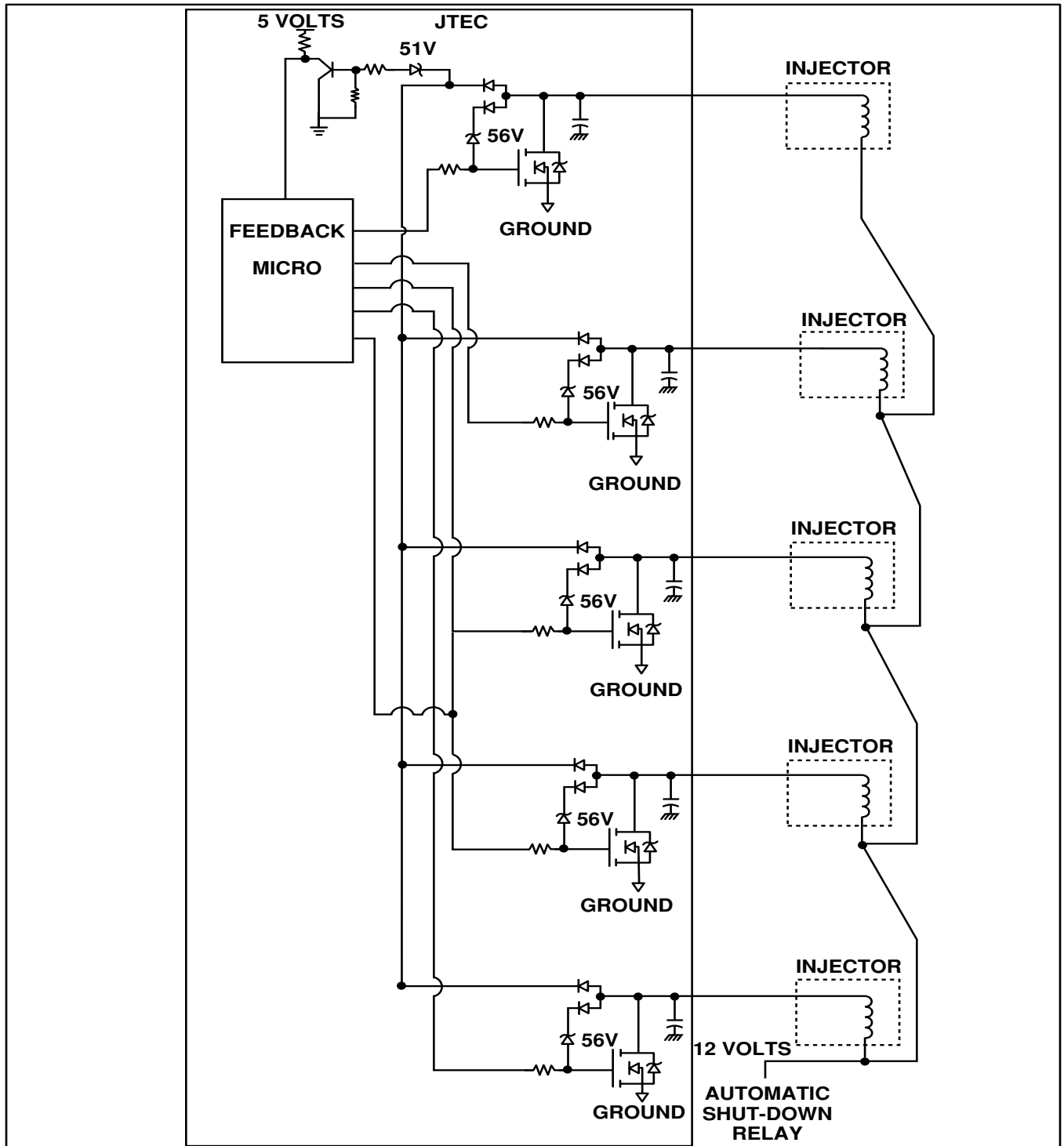

Figure 54 Fuel Injection Circuit



## 8.0L – V10 Fuel Injection

### Fuel Injector Diagnostics

To diagnose an injector, the PCM monitors the voltage spike created by the collapse of the magnetic field through the injector coil. The inductive kick is approximately 60 volts (fig. 55). Any condition that restricts maximum current flow would not allow the kick to occur, resulting in an injector fault.

See the description of fuel injectors in the Fuel System Components Section of this reference guide, for further information.

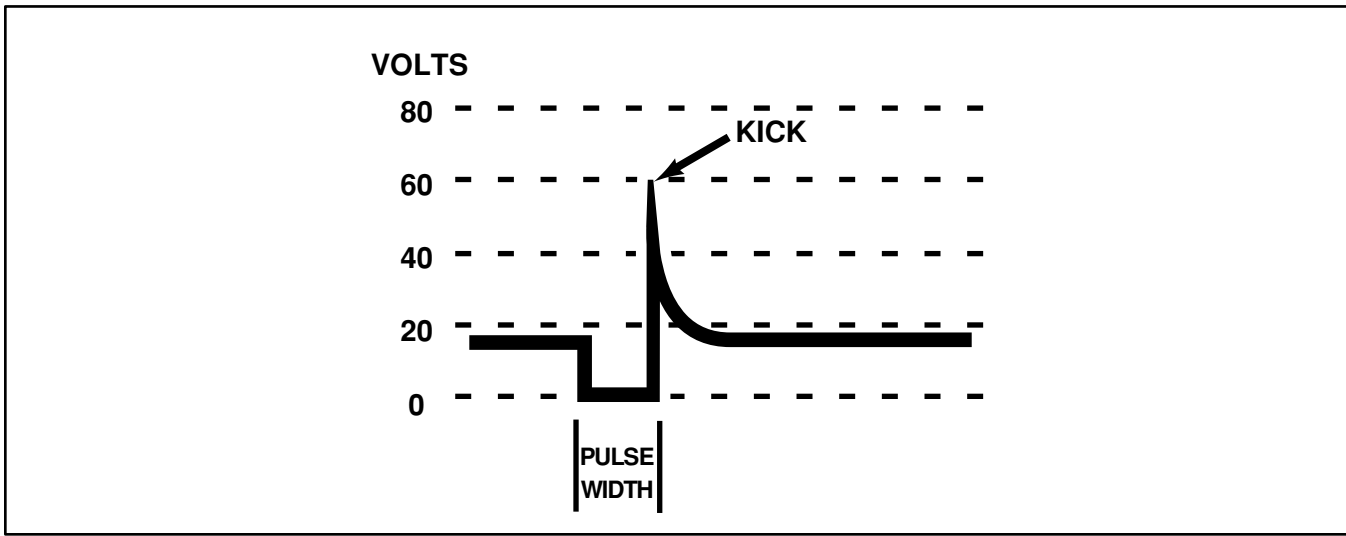

Figure 55 Injector Spike

# 8.0L – V10 Fuel Injection

## ACTIVITY 11 — FUEL PUMP/FUEL INJECTORS

### Activities

Have the instructor assign you to either a BR or SR vehicle. Use the DRB III and PEP module to assist in answering the following questions:

1. Connect a DRB III to the vehicle and actuate the ASD relay test. What happens?  
\_\_\_\_\_
2. Actuate the fuel pump relay test. What happens? \_\_\_\_\_
3. Change the DRB III to a Lab Scope. How much voltage is generated by either relay when the coil field collapses? \_\_\_\_\_
4. Start Engine. Go to sensors on the DRB III and display pulse width. How much time is shown?  
\_\_\_\_\_
5. Change the DRB III back to a Lab Scope. How much voltage is generated when the injector coil collapses? \_\_\_\_\_
6. Open the ground path to an injector. What does the scope display? \_\_\_\_\_

# 8.0L - V10 Fuel Injection

## IGNITION COILS

The PCM provides battery voltage to the ignition coils through the ASD relay (fig. 56). Coil operation is controlled by a ground path provided to the coil by the PCM. The ignition coil fires a spark plug at every power stroke.

The PCM determines when to fire the coil, based on camshaft and crankshaft sensor inputs. The ignition coil primary is joined to the power wire from the ASD relay. The ASD relay provides battery feed to the ignition coil, while the PCM provides a ground contact for energizing the coil. When the PCM breaks the ground contact, power transfers from the primary to the secondary, causing the spark.

Resistance on the primary side of the coil should be between 0.51 and 0.61 ohms. The resistance of the secondary side is between 11,500 and 13,500 ohms. The coil has the ability to provide up to 40,000 volts, if needed.

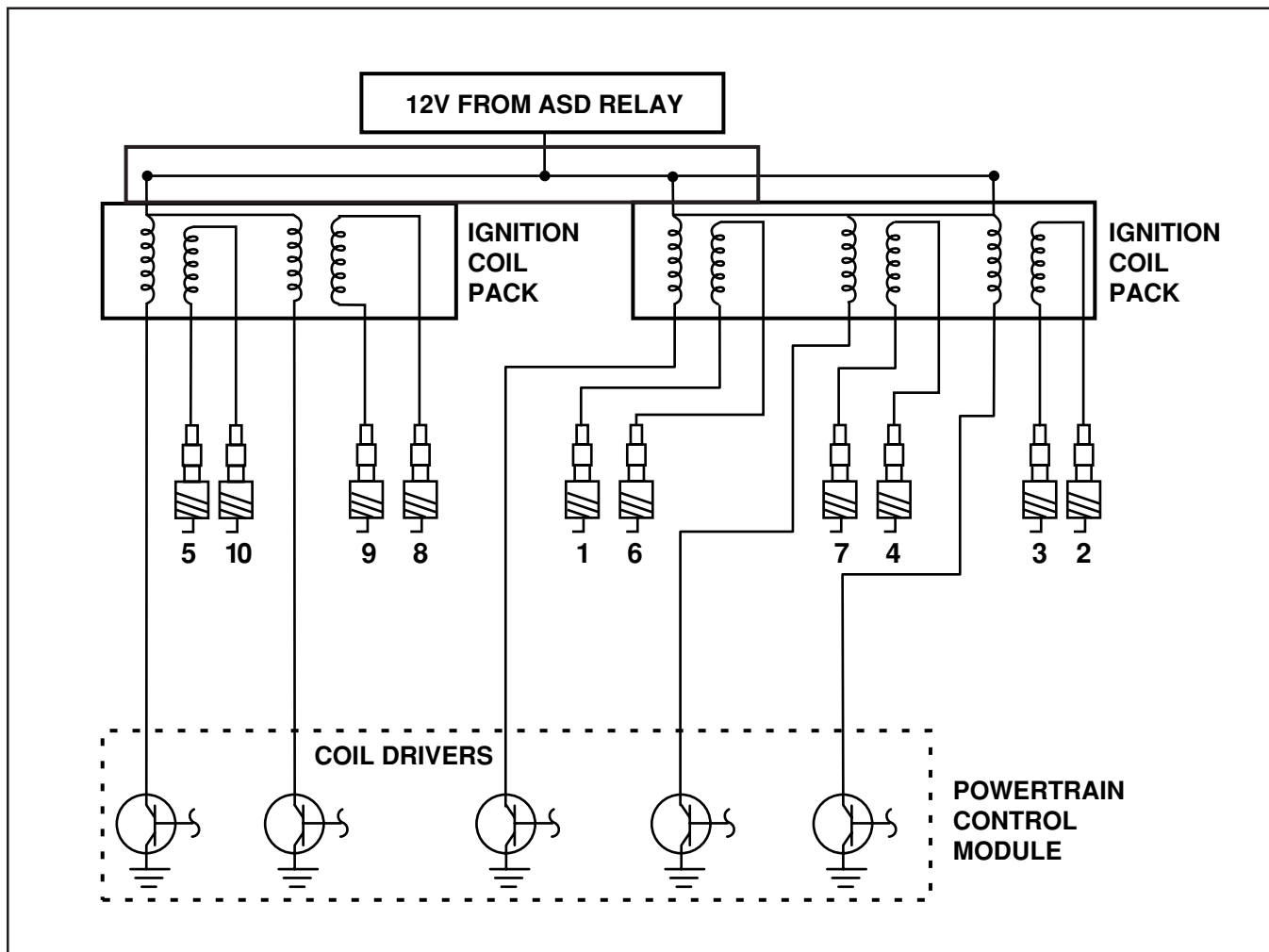

Figure 56 Ignition Control Circuit

# 8.0L – V10 Fuel Injection

## Coil Operation

When a conductor is formed into a coil, the magnetic field is many times stronger than that of a single straight connector. To increase the strength of the magnetic field, you must either increase the number of loops in the coil, increase the amount of current flowing in the coil, or use a low-reluctance material for the core of the coil.

If one coil is placed near another coil, and the first coil is connected to a current, the expanding magnetic field induces a current into the second coil. The current induced into a coil is much higher than a current induced into a straight conductor. The coil that carries current into this type of induction system is the primary winding of the coil. The coil into which electromotive force is induced, is the secondary winding of the coil. This mutual induction is the principle behind automotive ignition coils.

To induce a current, the magnetic field must be moving. Once the magnetic field has stabilized and is not expanding through the secondary conductor, no current is induced in the secondary conductor. As the field collapses, the lines of force pass through the secondary winding, which now induces a current in the opposite direction. When the field has completely collapsed, current flow in the secondary conductor stops.

The amount of secondary voltage generated depends on the amount of flux, the number of turns in the secondary coil, and the speed at which the primary current is interrupted. “Flux” refers to the lines of force in motion, which create a magnetic field. The amount of flux depends on the primary circuit. More current in this circuit means more flux. The flux moves through the windings of the secondary coil, so, more turns in the secondary coil result in more voltage. Flux collapses through the secondary coil when the primary current is interrupted. A quick interruption causes the flux to cut through the secondary windings faster. A quicker interruption results in more secondary voltage than a slow interruption.

DIS coils can be arranged in various alternations of polarity. It really does not matter if a spark fires positive or negative, as long as there is enough charge to jump the spark plug gap. The V10 engines use 2 separate coil packs. One coil pack is for cylinders 1 & 6, 7 & 4, and 3 & 2 while the other coil pack is for cylinders 5 & 10 and 9 & 8.

The spark from a DIS coil moves from tower to tower using the block as a piece of wire to complete the circuit. This means that if any part of the circuit opens, both spark plugs will not fire. A spark will jump across the tip of the spark plug still connected to a coil tower. However, this spark is created by a capacitance effect and will not support a load on the engine.

# 8.0L – V10 Fuel Injection

## PCM Operation

The PCM toggles the ignition coil current driver ON, and then at some point before the CKP sensor indicates TDC, toggles it off. The amount of ON time (dwell), and the point at which the PCM toggles the driver OFF, is determined by several inputs to the PCM. To achieve the best spark advance program, the PCM calculates when to energize and de-energize the ignition coil.

These calculations require inputs from:

- CKP sensor
- MAP sensor
- ECT sensor
- IAT sensor
- TPS
- Engine rpm
- Battery voltage
- Park/Neutral position switch

Base timing is non-adjustable but is set from the factory at approximately 10° BTDC, when the engine is warm and idling.

Dwell is a constant at low rpm based on battery voltage. The constant dwell allows for a constant voltage at the coil for a consistent spark. However, at higher rpm there isn't enough time for full saturation, so the PCM changes to an 80-20 duty cycle. By allowing current to flow 80% of the time, a sufficient magnetic field can be built regardless of rpm. This duty cycle allows for sufficient spark to operate.

As mentioned previously, the resistance of the coil primaries have a resistance of only .5 ohms. These are known as low impedance coils. Because of the low resistance the coils can allow significant current flow in excess of 15 amps. A rapid high current flow means a faster moving magnetic field which means a quicker coil saturation. To protect the PCM from damage due to high current flow there is a current sensing device in the coil output circuit. As dwell time starts the PCM allows full current flow. When the sensing device registers 8 amps the PCM begins to regulate current flow to maintain and not exceed 8 amps for the remainder of the dwell time.

## Spark Plug – BR

The spark plug on the BR is an inductive suppressor plug. Instead of having a resistor built into the plug there is a fine wire wound around a ceramic core. This inductive suppressor is a much lower resistance than a resistor suppressor which changes the characteristics of the arc energy. This results in lowering the amount of radio frequency interference that is emitted by the spark (secondary ignition system).

# 8.0L – V10 Fuel Injection

## IDLE AIR CONTROL (IAC) STEPPER MOTOR

### Description

The IAC stepper motor is mounted to the throttle body on a BR, and the front of the intake manifold on an SR, and regulates the amount of air bypassing the control of the throttle plate. As engine loads and ambient temperatures change, engine rpm also changes. A pintle on the IAC stepper motor protrudes into a passage in the throttle body on a BR, and connected to both intake manifold plenums on the SR, controlling airflow through the passage. The IAC is controlled by the PCM to maintain the target engine idle speed.

At idle, engine speed can be increased by retracting the pintle and allowing more air to pass through the port, it can be decreased by restricting the passage with the pintle and diminishing the amount of air bypassing the throttle plate.

When engine rpm is above idle speed, the IAC is used for the functions listed below.

- Off-idle dashpot
- Deceleration airflow control
- A/C compressor load control (also opens the passage slightly before the compressor is engaged so that the engine rpm does not dip down when the compressor engages)

The PCM can control polarity of the circuit to control direction of the stepper motor.

### Operation

The IAC is called a stepper motor because it is moved in “steps.” The IAC motor is capable of 255 total steps, from fully closed to fully open. Opening the IAC in turn opens an air passage around the throttle blade which increases rpm.

The PCM uses the IAC motor to control idle speed (along with timing) and to reach a desired MAP during decel (keep engine from stalling).

The stepper motor has four wires (fig. 55). Two wires are for 12 volts and ground. The other two wires are for 12 volts and ground. The stepper motor is not really a motor at all. The pintle that moves in and out can be thought of as a bolt with threads (fig. 65). The “nut” is a permanent magnet. There are two windings by the permanent magnet. When the PCM energizes one set of windings, this makes an electromagnet. The permanent magnet, which is allowed to rotate, is attracted to the electromagnet and rotates until the north and south poles line up. Once the poles line up, the nut stops turning. At this time, the PCM will energize the other winding. This moves the “nut” one more step. As the nut turns, the pintle (bolt) moves out or in.

To make the IAC go in the opposite direction, the PCM just reverses polarity on both windings. If only one wire is open, the IAC can only be moved one step in either direction.

**NOTE:** *To keep the IAC motor in position when no movement is needed, the PCM will energize both windings at the same time. This locks the IAC motor in place.*

# 8.0L - V10 Fuel Injection

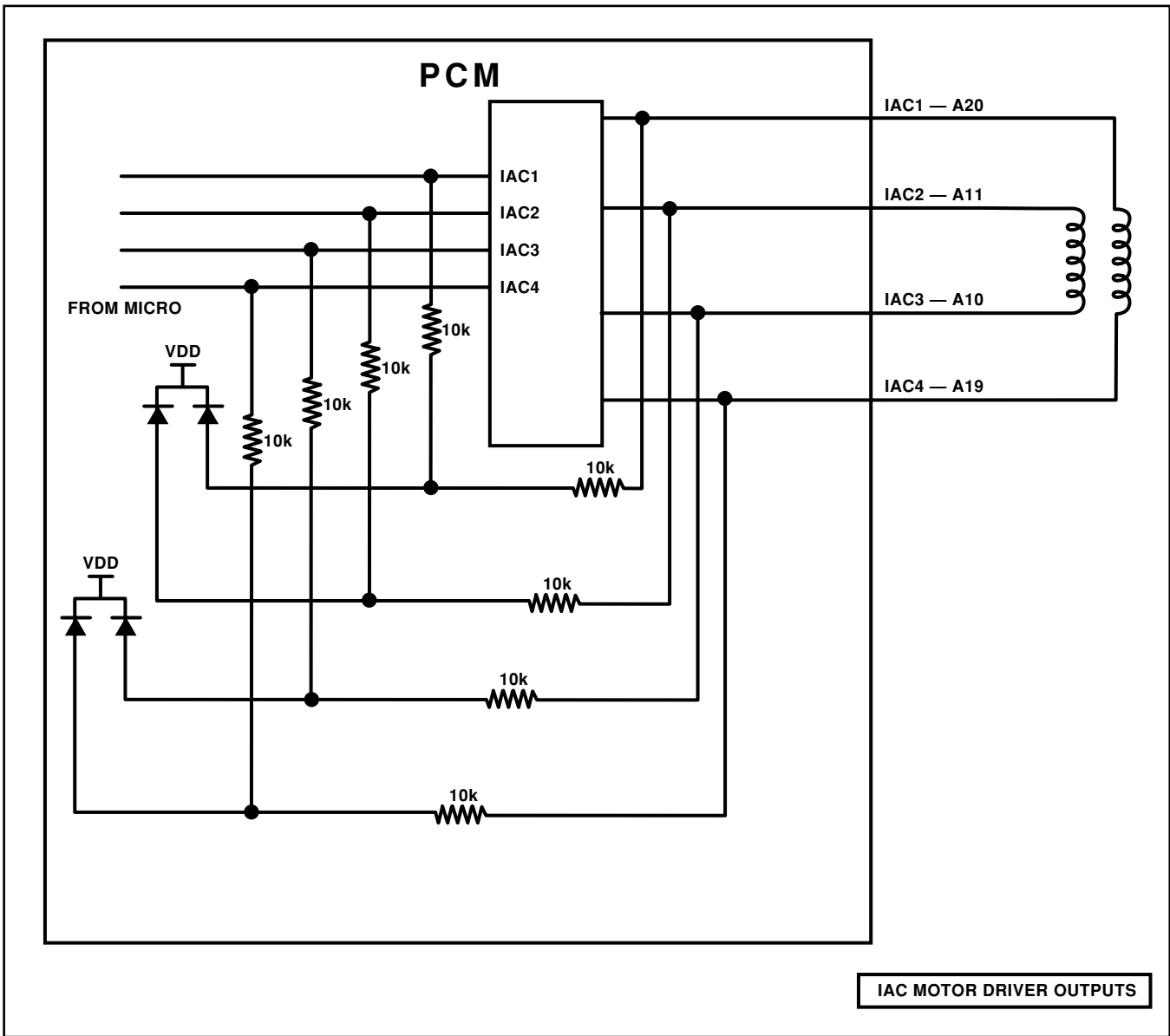

Figure 57 IAC Motor Control Circuit

## 8.0L - V10 Fuel Injection

In the IAC motor system, the PCM will count every step that the motor is moved. This allows the PCM to “know” the motor pintle position. If the memory is cleared, the PCM no longer knows the position of the pintle. So, at the first key ON, the PCM drives the IAC motor closed, regardless of where it was before. This “zeros” the counter. From this point, the PCM will back out the IAC motor and keep track of its position again.

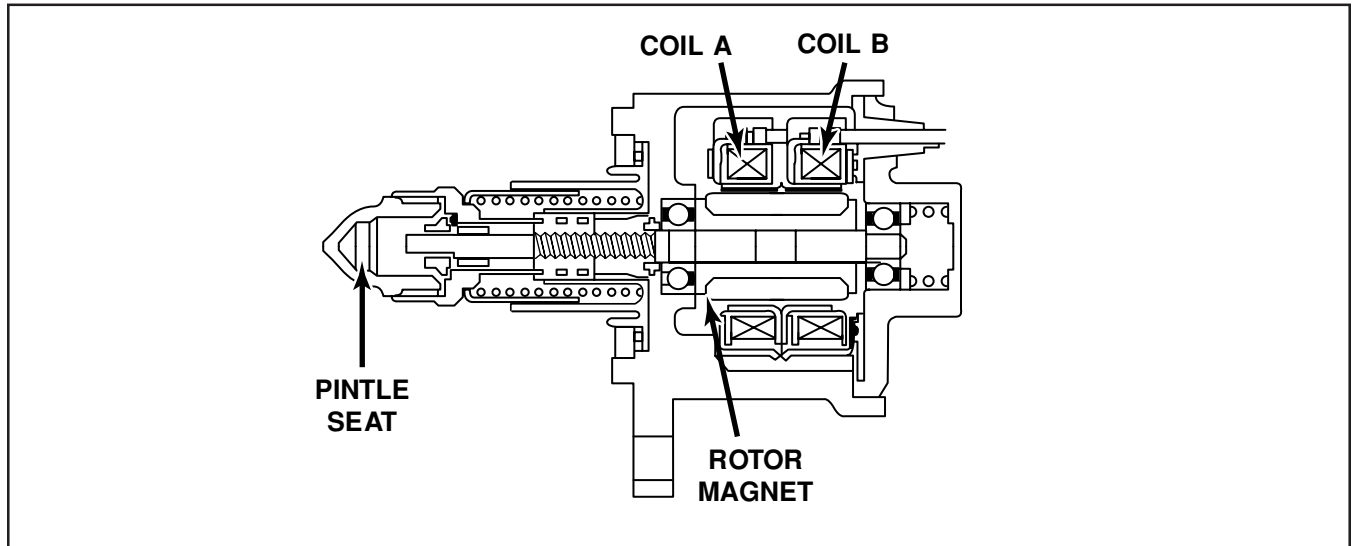

Figure 58 IAC Internal View



## 8.0L – V10 Fuel Injection

### IAC Stepper Motor Program

When the pintle has completely blocked the air passage, the IAC stepper motor is at step zero (fig. 59). The PCM has the authority to increase the opening by approximately 200 steps. The IAC stepper motor cannot identify in exactly which position the pintle is, so the PCM has a program that enables it to learn the position of the IAC pintle.

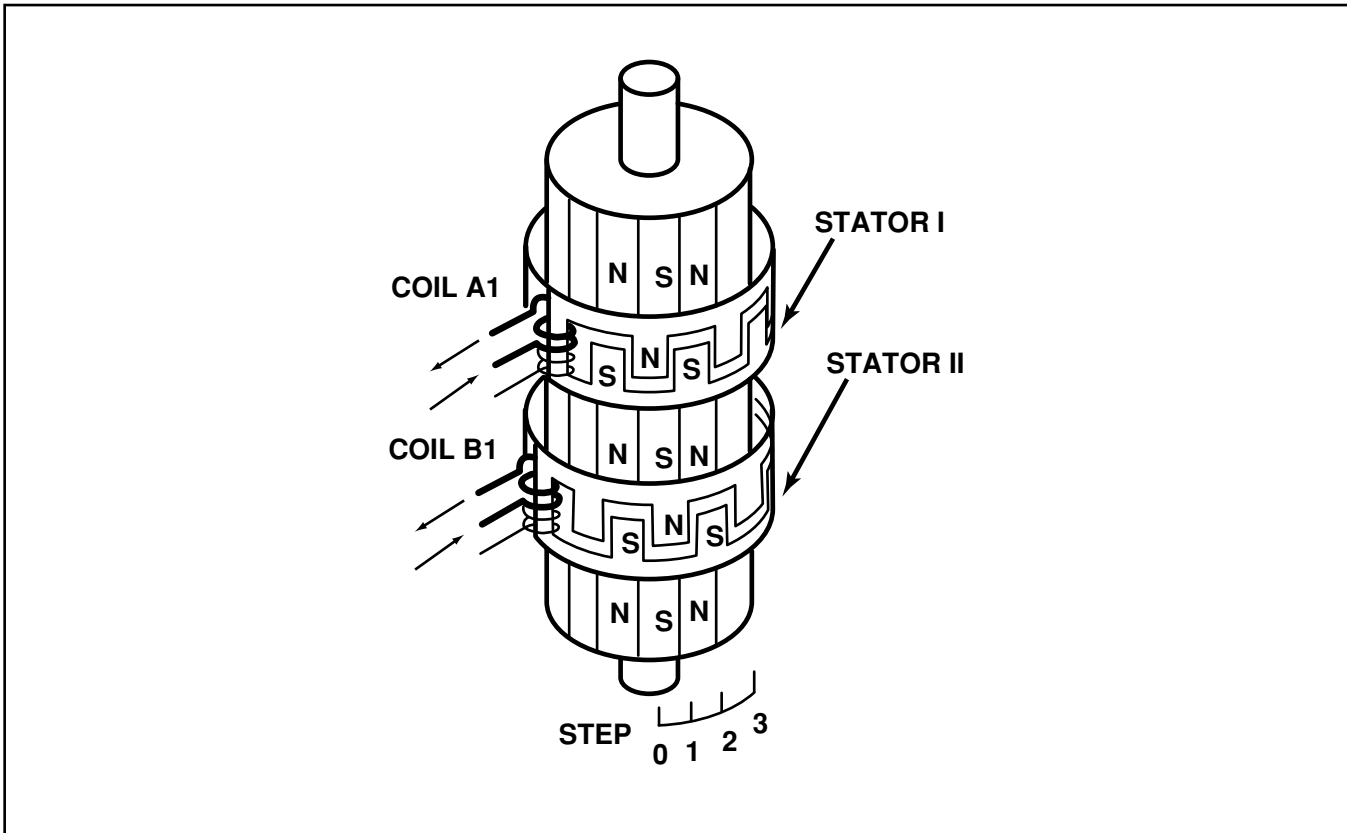

Figure 59 IAC Motor

The program begins by learning step zero. This is accomplished by the PCM driving the IAC stepper motor closed for several seconds when the key is first turned to the RUN position after a battery disconnect. The PCM assumes that, at the end of the cycle, the IAC stepper motor should be at step zero. Once the stepper motor finds step zero, the PCM backs the motor to the open position. The number of steps needed to arrive at the open position is based upon information delivered by the ECT sensor. The program can be updated by the DRB III, or by disconnecting battery voltage from the PCM and then reconnecting it.

The PCM is also equipped with a memory program that records the number of steps the IAC stepper motor most recently advanced to during a certain set of parameters. For example: The PCM was attempting to maintain a 750 rpm target during a hot start-up cycle. The last recorded number of steps for that may have been 27. That value would be recorded in the memory cell, so that the next time the PCM recognizes the identical conditions, the PCM recalls that 27 steps were required to maintain the target. This program allows for greater customer satisfaction due to greater control of engine idle.

## 8.0L – V10 Fuel Injection

Another function of the memory program during that key cycle occurs when the A/C request circuit requires the IAC stepper motor to control engine rpm. This is the recording of the last targeted steps.

As mentioned earlier, the PCM can “anticipate” compressor loads. This is accomplished by delaying compressor operation for approximately 0.5 second, until the PCM moves the IAC stepper motor to the recorded steps that were loaded into the memory cell. Using this program helps eliminate idle-quality changes as loads change.

### Target Idle

Target idle is determined by the following inputs:

- Engine Coolant Temperature Sensor
- Park/Neutral Position switch

### IAC Motor Position

The IAC motor position is determined by the following inputs:

- Engine Coolant Temperature sensor
- Battery Voltage
- Vehicle Speed (VSS)
- Throttle angle (TPS)
- MAP
- Park/Neutral Position switch
- RPM
- A/C Compressor

### IAC Stepper Motor Service

Anytime the IAC stepper motor or its circuit is serviced, the IAC memory cell must be updated. Use the DRB III to “Reset IAC.” This ensures that the PCM can identify step zero. Also, be sure that when the IAC stepper motor is installed into the throttle body, the passage is clear of debris and that the pintle does not protrude too much. Before installing an IAC motor, make sure that the pintle is in a retracted position. This will ensure that the pintle and seat are not damaged when the IAC motor is installed.

### IAC Diagnostics

IAC Diagnostics have changed with the use of JTEC. Open circuits are diagnosed if they are present at key-on. However, if a driver circuit opens while the engine is running, it will not be diagnosed until the next key-on cycle.

Short circuits to B+ and ground are diagnosed at key-on and also while the engine is running.

# 8.0L – V10 Fuel Injection

## ACTIVITY 12 – IAC MOTOR

Use DRB III and create custom display:

- MAP vacuum
- Eng. RPM
- Target idle
- IAC STEPS
- Target IAC STEPS
- Spark advance
- Min TPS
- Actual TPS volts

1. Restrict airflow (dirty air cleaner) by hand. What did you observe?

\_\_\_\_\_

2. Make a vacuum leak. What did you observe? \_\_\_\_\_

3. Open the circuit at all four IAC circuits. What did you observe?

\_\_\_\_\_

4. Close the vacuum leak. Note timing, rpm and IAC steps. What did you observe?

\_\_\_\_\_

5. Turn the engine OFF. Close all four IAC circuits. Turn Key ON. Where are the steps now?

\_\_\_\_\_

Was there an idle flare? \_\_\_\_\_

Should there have been one? \_\_\_\_\_

6. Move P/N to drive gear (open BOB). What happened to the IAC steps?

## Systems Test

7. Perform the IAC wiggle test. Open one circuit on BOB. What happened to IAC steps? \_\_\_\_\_

## Miscellaneous

8. Reset memory and IAC counter. Go back to custom display. Start the engine. What did you observe? \_\_\_\_\_

9. Hook up a second IAC. Go to Misc. Reset IAC. What did pintle do? \_\_\_\_\_

\_\_\_\_\_

# 8.0L - V10 Fuel Injection

## RADIATOR FAN RELAYS - SR

### Radiator Fan ON Relay

The radiator fan ON relay energizes when the PCM provides a ground to the relay. The radiator fan relay is located below the heater blower motor housing.

In 1996, the cooling fan was turned off at 62 mph during acceleration and turned back on at 52 mph during deceleration. In 1997, the fan is turned off at 77 mph during acceleration and turned back on at 67 mph during deceleration.

### Radiator Fan Low/High Relay

The radiator fan LOW/HIGH relay works in conjunction with the radiator fan ON relay. If the coolant temperature is below 102°C (216°F) the current flow for the fan is through the normally closed contacts of the LOW/HIGH relay. If the coolant temperature is above 102°C (216°F) the PCM grounds the LOW/HIGH relay and the radiator fan changes to high speed. The PCM turns off high speed fan operation when coolant temperature drops to 102°C (216°F). The low speed will continue until temperature drops below 94°C (201°F).

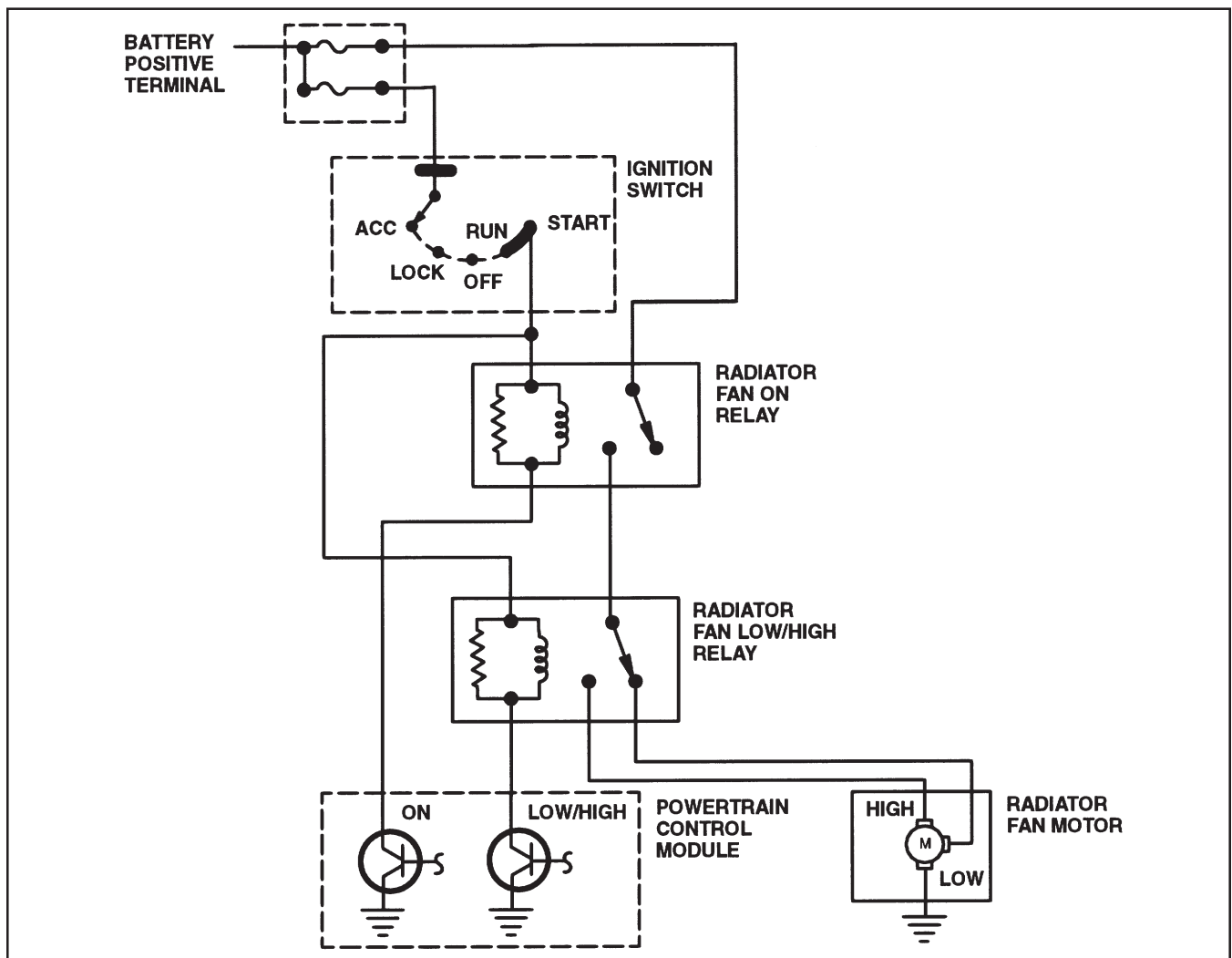

Figure 60 Radiator Fan Relay Circuit

# 8.0L – V10 Fuel Injection

## Generator Field Control (Except '96 Roadster)

The PCM regulates charging system voltage and determines the final goal or “target charging voltage.” The target charging voltage is controlled mainly by the battery temperature sensor, which is located under the battery tray. Power to the generator field winding is supplied by the ASD relay. For 1997 Ram Truck instead of the ASD supplying the power to the field winding, the PCM supplies the power at pin B10. This supply is connected internally to the ASD sense input. Field control is still accomplished by the PCM supplying the ground for the field winding (figs. 61 and 62).

The PCM monitors battery voltage. If it senses that battery voltage is more than 0.5 volt lower than the target voltage, the PCM grounds the field winding until sensed battery voltage is 0.5 volt above target voltage. A circuit in the PCM cycles the ground side of the generator field up to 100 times per second (100 Hz), but has the capability to ground the field control wire 100% of the time full field, to achieve the target voltage. If the charging rate cannot be monitored (limp-in), a duty cycle of 25% is used by the PCM in order to have some generator output.

For 1997, instead of supplying the power to the field winding, the PCM supplies the power at pin B10. This supply is connected internally to the ASD sense input. Field control is still accomplished by the PCM supplying the ground for the field winding.

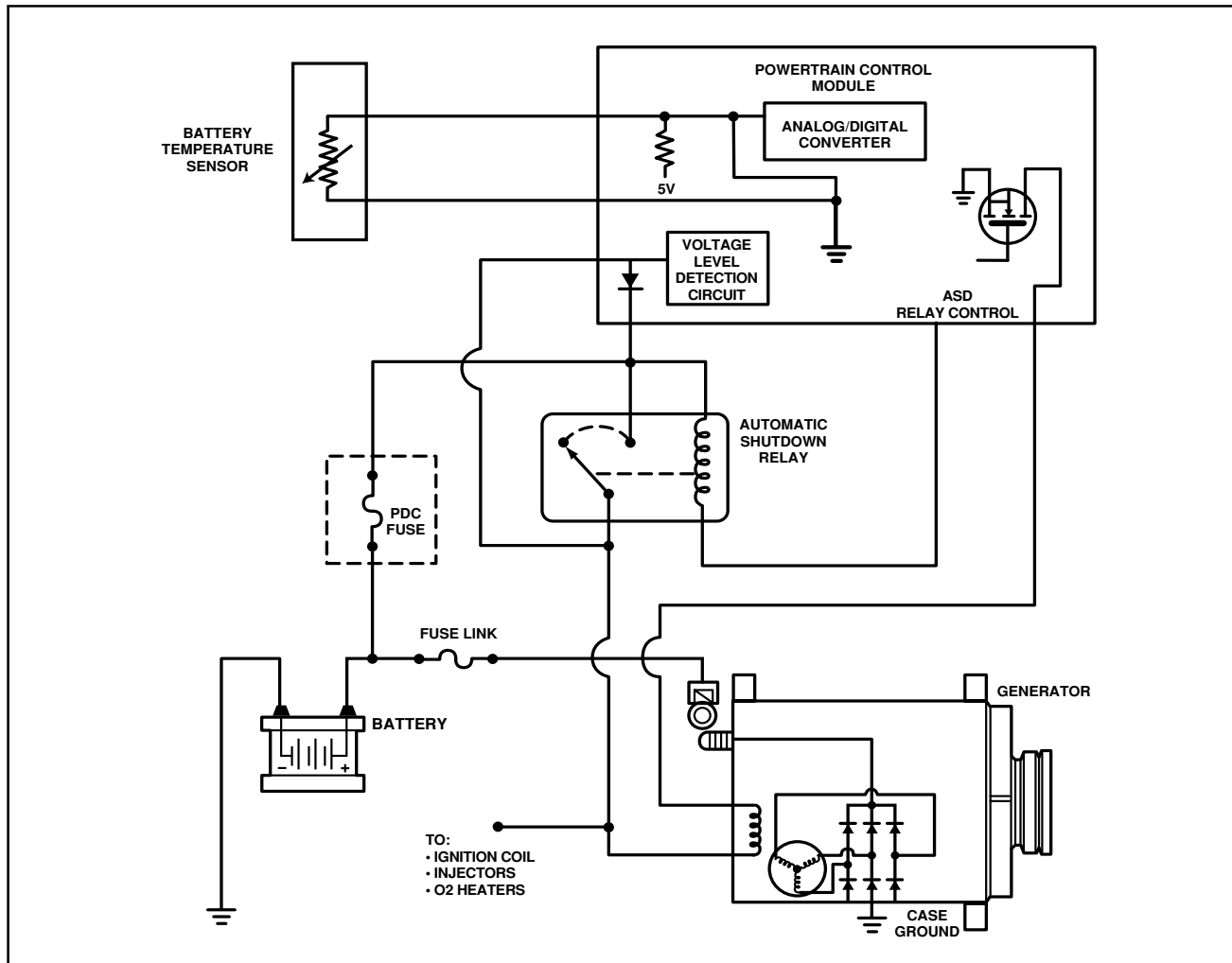

Figure 61 Generator Field Control Circuit — Typical '96

# 8.0L - V10 Fuel Injection

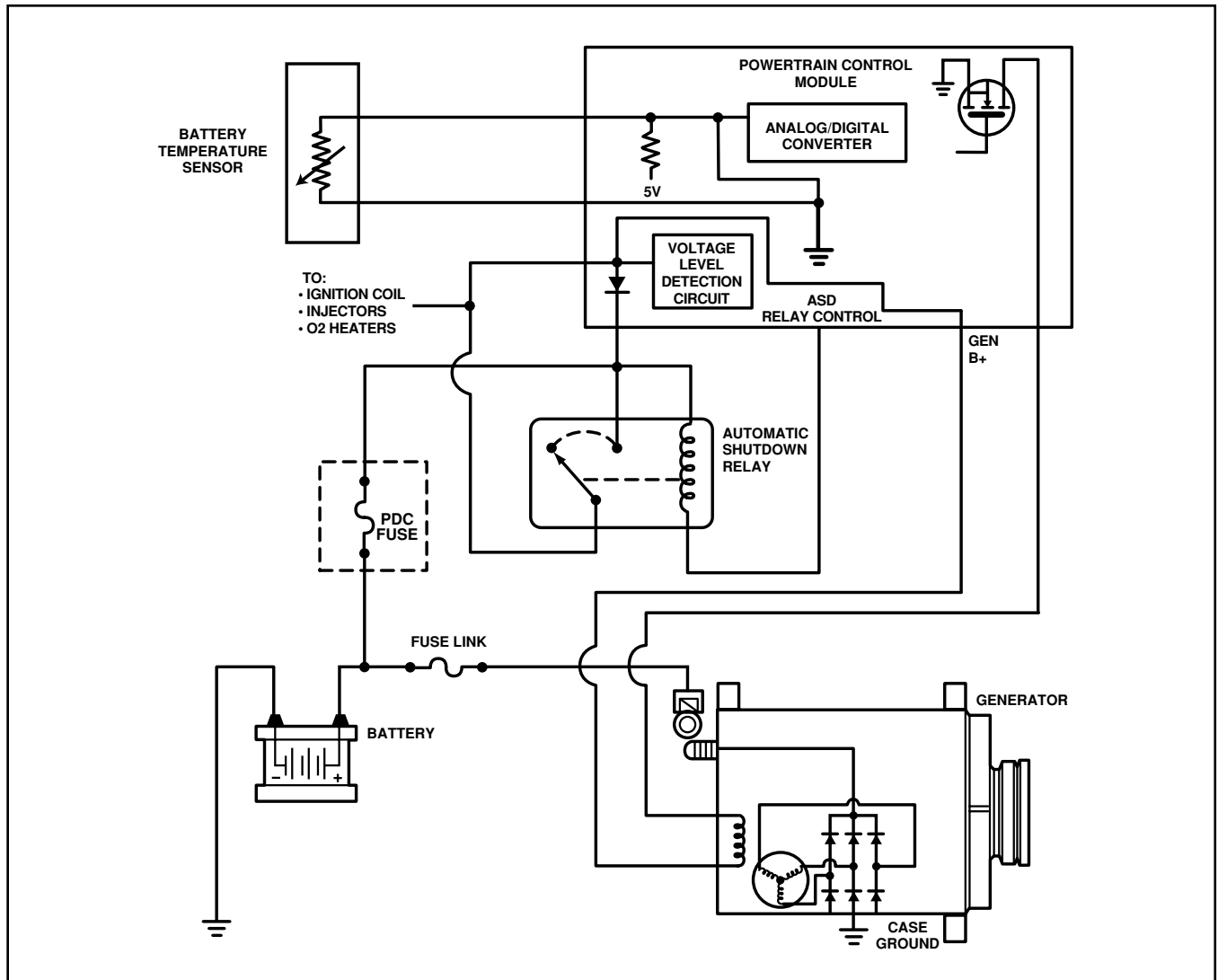

Figure 62 Generator Field Control Circuit — 1997 Ram Truck

## 8.0L - V10 Fuel Injection

### CHARGING SYSTEM INDICATOR LIGHT (GEN. LAMP) - EXCEPT 96 ROADSTER

The PCM controls the operation of the charging-system indicator light, located in the vehicle's instrument cluster. On 1996 and 1997 vehicles, the PCM provides a ground to complete the lamp circuit if a charging system fault is set (fig. 63). The 1998 vehicles bus the charging-system indicator light signal over the CCD bus to the instrument cluster.

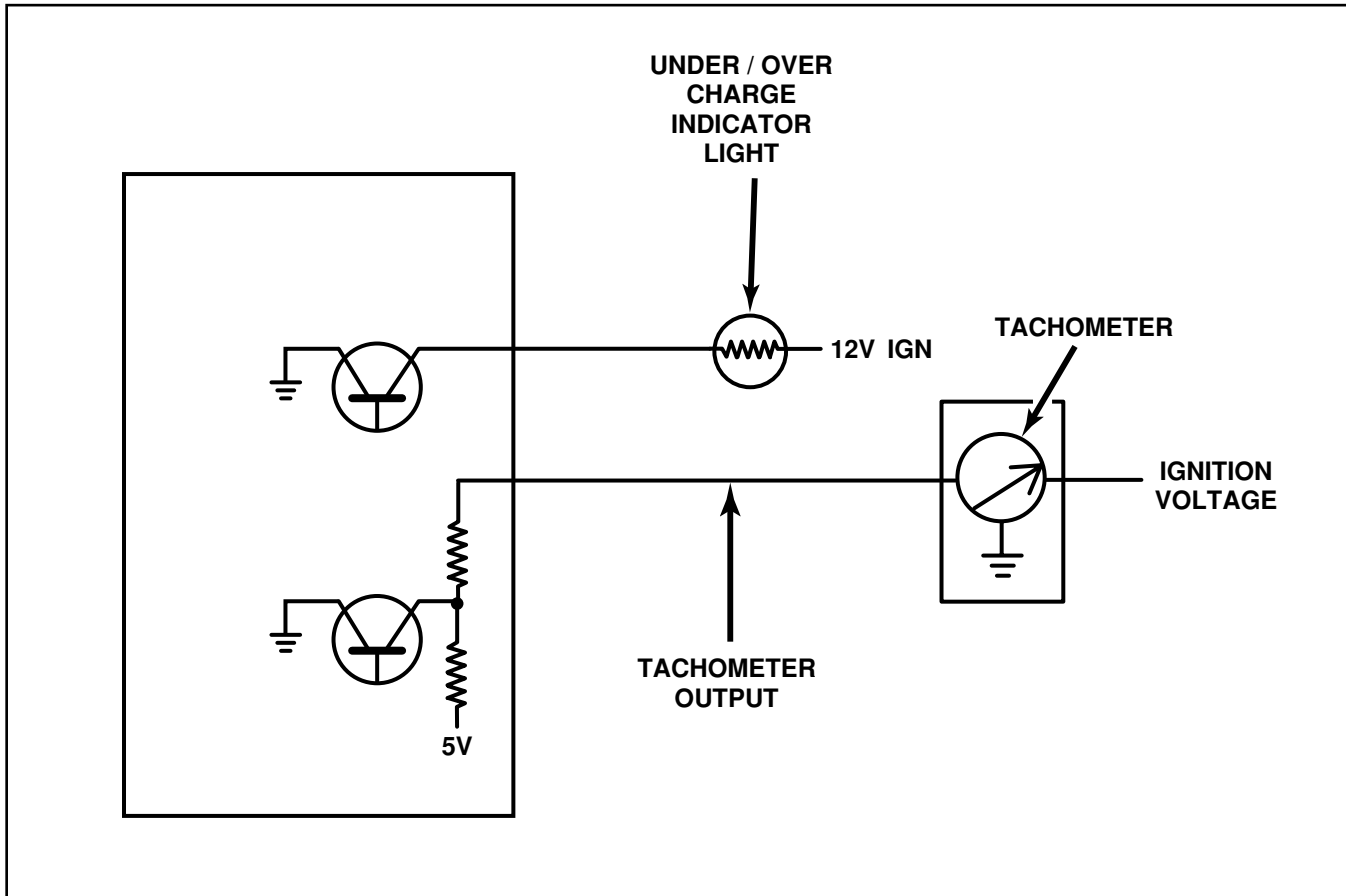

Figure 63 Generator Lamp Control Circuit

### TACHOMETER

On 1996 and 1997 vehicles, the PCM operates the tachometer which is located in the instrument panel. The PCM provides duty-cycle output voltage to the tachometer. The frequency of the duty cycle is based upon engine speed which is calculated from inputs from the CKP and CMP sensors. On 1998 BR vehicles the PCM will transmit the engine rpm signal over the CCD bus to the instrument cluster.

### TORQUE CONVERTER CLUTCH SOLENOID (AUTO TRANS ONLY)

On vehicles equipped with an automatic transmission, the PCM operates the torque-converter clutch solenoid. The PCM controls engagement of the clutch by providing the ground for the solenoid. The automatic transmission will allow the torque converter clutch to engage if the transmission is in third or fourth gear.

# 8.0L – V10 Fuel Injection

## OVERDRIVE LAMP – BR

This circuit controls a signal for the operation of the push-button overdrive lamp switch. When the lamp is illuminated, the overdrive is disengaged.

Refer to the Transmission section for more information.

## TRANSMISSION RELAY – BR

The output to this relay provides battery voltage to the 3-4 shift solenoid, torque-converter clutch solenoid and the governor pressure solenoid. Once battery voltage is applied to the solenoids, they are individually activated by the PCM through OD, TCC and governor pressure outputs.

If the relay output is open or shorted to ground when it should be off, or the output is shorted to 12 volts when it should be on, a fault will be set.

## THREE-FOUR SHIFT SOLENOID – BR

This output controls the transmission 3-4 shift solenoid. It is used on 4-speed, electronically controlled, automatic transmissions only.

Refer to the Transmission section for more information.

## REVERSE LOCKOUT SOLENOID – SR

The reverse lockout solenoid prevents the operator from shifting into reverse when the vehicle speed is greater than 5 mph. When vehicle speed is less than 5 mph the PCM provides a ground for the solenoid (energized) and allows shifting. When vehicle speed is greater than 5 mph the solenoid is deactivated and prevents the transmission from being shifted into reverse.

## FIRST TO FOURTH GEAR SHIFT INDICATOR LAMP – SR

The PCM operates the skip shift indicator lamp. The lamp informs the driver that if the transmission is shifted while the lamp is on that the shift lever will be redirected to fourth gear “skipping” 2nd and 3rd completely. The PCM illuminates the shift lamp when the following conditions have been met:

- Vehicle speed between 12 and 18 mph
- Transmission in first gear (speed/RPM)
- Engine speed greater than 608 RPM
- Throttle position less than 23 percent (less than 0.68 volts over closed throttle TPS voltage)
- Coolant temperature above 41°C (106°F)

## SKIP SHIFT SOLENOID – SR

The skip shift solenoid prevents the operator from shifting from first gear into second and third gear during certain conditions. The PCM controls the skip shift solenoid. The PCM locks out second and third gear when all of the following conditions are met:

- Engine coolant exceeds 41°C (106°F)
- Vehicle speed is between 12 and 18 MPH
- Engine operating above 608 RPM
- The PCM verified first gear speed/RPM
- Throttle position sensor (TPS) signal is less than 0.68 volt above close throttle (23 percent throttle opening)



## 8.0L – V10 Fuel Injection

The solenoid program resets when vehicle speed drops back below 2 MPH and is considered completed once these conditions have exceeded whether the transmission was shifted or not.

### GOVERNOR PRESSURE SOLENOID – BR

This solenoid regulates the transmission-fluid line pressure to produce the governor pressure necessary for transmission shift control. It is used on 4-speed, electronically controlled, automatic transmissions only.

Refer to the Transmission section for more information.

### MALFUNCTION INDICATOR LAMP (MIL)

The MIL (CHECK ENGINE) lamp is located in the instrument cluster and can illuminate under more conditions than on previous models.

The PCM operates the MIL which illuminates for a three-second bulb test whenever the ignition is turned ON. The MIL lamp remains continuously illuminated when an emissions component fails, or when the vehicle enters a limp-in mode. In limp-in mode, the PCM provides programmed inputs to keep the vehicle operational.

Because the vehicle is equipped with OBD II diagnostic capabilities, the MIL flashes if the onboard diagnostic system detects engine misfire severe enough to damage the catalytic converter. The vehicle should not be driven if this occurs.

Anytime the MIL is illuminated, a DTC is stored and the PCM must meet certain criteria to extinguish the lamp. On vehicles equipped with OBD I (Heavy Duty BR) diagnostics, on prior year models, the MIL would normally extinguish after the problem that caused the MIL to illuminate was no longer present, and the key had been cycled from OFF to ON one time. However, on **ALL** BR/SR vehicles three consecutive good trips must occur to extinguish the MIL.

If a problem occurred with one of the main OBD II monitors, the PCM must pass the test of the monitor that failed three consecutive times. On the fourth key-on register the MIL is extinguished.

DTCs that were stored can be erased automatically only after the MIL has been extinguished and 40 warm-up cycles have occurred or with the DRB III.

### Trip Definition — SR/97BR

The term “trip” has different meanings depending on the circumstances. If the MIL (Malfunction Indicator Lamp) is OFF, a trip is when the Oxygen Sensor Monitor and the Catalyst Monitor have been completed in the same drive cycle.

When any emission DTC is set, the MIL on the dash is turned ON. When the MIL is ON, it takes three “good” trips to turn the MIL OFF. In this case, it depends on what type of DTC is set to know what a trip is. The minimum requirement is engine running for 2 minutes with no faults detected.

For the Fuel Monitor or Misfire Monitor (continuous monitor), the vehicle must be operated in the “Similar Condition Window” for a specified amount of time to be considered a good trip.

## 8.0L – V10 Fuel Injection

Non-continuous OBD II monitors include:

- Oxygen Sensor.
- Catalyst Monitor.
- Purge Flow Monitor.
- Leak Detection Pump Monitor (if so equipped).
- Oxygen Sensor Heater Monitor.

If any of these monitors fail twice in a row on two separate key cycles, turn on the MIL, and successfully rerun on the next start-up, it is considered a good trip.

Other examples of good trips are:

- Completion of O<sub>2</sub> Sensor and Catalyst monitors after an emissions DTC (not an OBD II monitor) is set.
- Engine run-time of two minutes if the Oxygen Sensor Monitor or Catalyst Monitor have been stopped from running.

It can take up to two failures in a row to turn on the MIL. After the MIL is ON, it takes three good trips to turn the MIL OFF. After the MIL is OFF, the PCM will self-erase the DTC after 40 warm-up cycles. A warm-up cycle is counted when the ECT (Engine Coolant Temperature) sensor has crossed 160°F and has risen by at least 40°F since the engine was started.

Refer to the OBD II course for a complete explanation.

### **EVAPORATIVE PURGE SOLENOID**

The PCM controls Evaporative Purge Solenoid operation and provides a ground path that allows the solenoid to open. Refer to the Emission Control Systems section of this publication for more information.

### **LEAK-DETECTION PUMP SOLENOID (STARTING IN 1998)**

The PCM energizes the Leak-Detection Pump Solenoid when specific operating conditions have been met. Refer to the Emission Control Systems section of this publication for more information.

### **SPEED-CONTROL SERVO SOLENOIDS**

The PCM on all vehicles operates the ground side of the vacuum and vent solenoids of the servo. Refer to the Vehicle Speed Control System section of this publication for more information.

# 8.0L - V10 Fuel Injection

## LESSON 6

### EMISSIONS CONTROL SYSTEMS

The emissions control system is comprised of two major segments: evaporative emissions and exhaust emissions. Its function is to control the output of hydrocarbons (HC), carbon monoxide (CO) and oxides of nitrogen (NO<sub>x</sub>). The PCM controls exhaust emissions by monitoring the inputs and controlling fuel and ignition systems. A three-way catalyst is also used.

#### EVAPORATIVE EMISSION CONTROL

The evaporative control system consists of a fuel cap, rollover valves, vapor lines, fuel filler neck, evaporative canister, Duty Cycle Purge (DCP) solenoid, orifice and vapor lines. On some vehicles, there is also an Evaporative System Leak Detection pump (fig. 64).

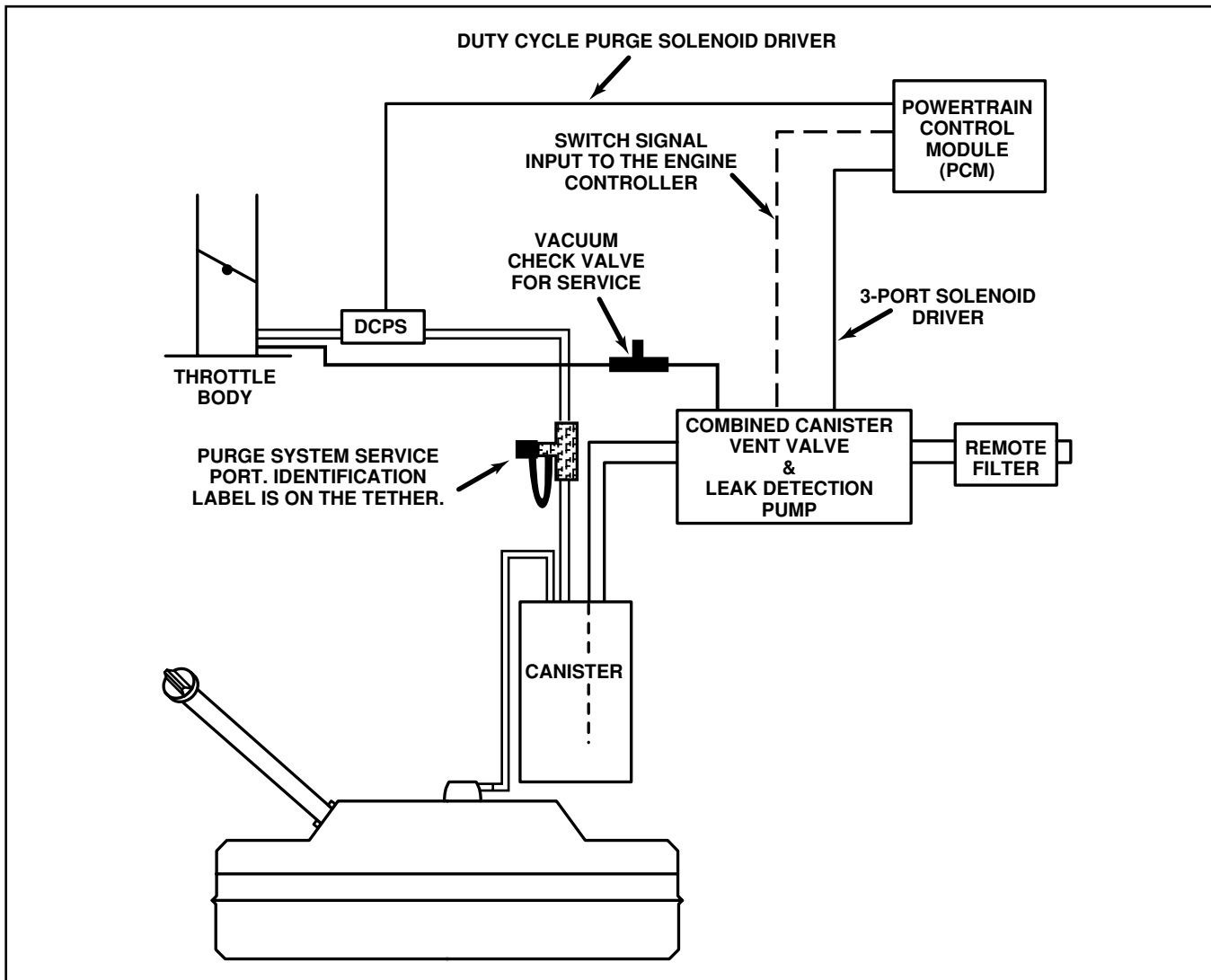

Figure 64 EVAP LDP System

# 8.0L – V10 Fuel Injection

## Fuel Filler Cap

The fuel filler cap is a screw-on type, with a ratchet mechanism to keep the tightening force on the filler cap constant. Also, the cap is equipped with a valve to relieve both pressure and vacuum extremes in the fuel tank.

## Rollover Valves

The rollover valve is designed to allow fuel tank vapors to be routed to the canister. If an accident causes the vehicle to overturn, a check valve prevents fuel from entering the vapor line (fig. 64).

On Ram pickup trucks and Vipers, the rollover valve is located in the top of the fuel pump module and it is replaceable.

## Evaporative Charcoal Canister

The evaporative charcoal canister temporarily stores fuel vapors until intake manifold vacuum draws them into the combustion chamber. The charcoal canister has its own fresh air intake.

## Duty-Cycle Purge Solenoid

The Duty-Cycle Purge solenoid is used to control the flow of vapors to the intake manifold (fig. 65). Operation of the solenoid is controlled by the PCM which provides a ground path that allows the solenoid to open, allowing vapor flow.

## Fuel-Vapor Recovery System (Duty-Cycle Purge Control)

Duty Cycle Purge is a system that feeds fuel gases from the purge canister and gasoline tank into the throttle body for mixing with incoming air. The system meters gases when the PCM duty-cycles the purge solenoid.

The system is disabled during Wide Open Throttle (WOT) conditions and while the engine is below a specified coolant temperature. When engine temperature exceeds a calibrated parameter, duty cycle purge is delayed for a calibrated time. Once purge delay is over, purge will be ramped in to soften the effect of dumping additional fuel into the engine.

The PCM provides a duty-cycle operating at 5 Hz (at closed throttle) or 10 Hz (at open throttle) to control this system. The duty-cycle is based upon a calculated airflow (based upon known fuel flow through the injector at a given pulse width and rpm) and is adjusted to compensate for changes in flow due to varying engine vacuum.

The duty-cycle represents the amount of On/Off time, while the Hz represents how often the duty-cycle is repeated.

## 8.0L - V10 Fuel Injection

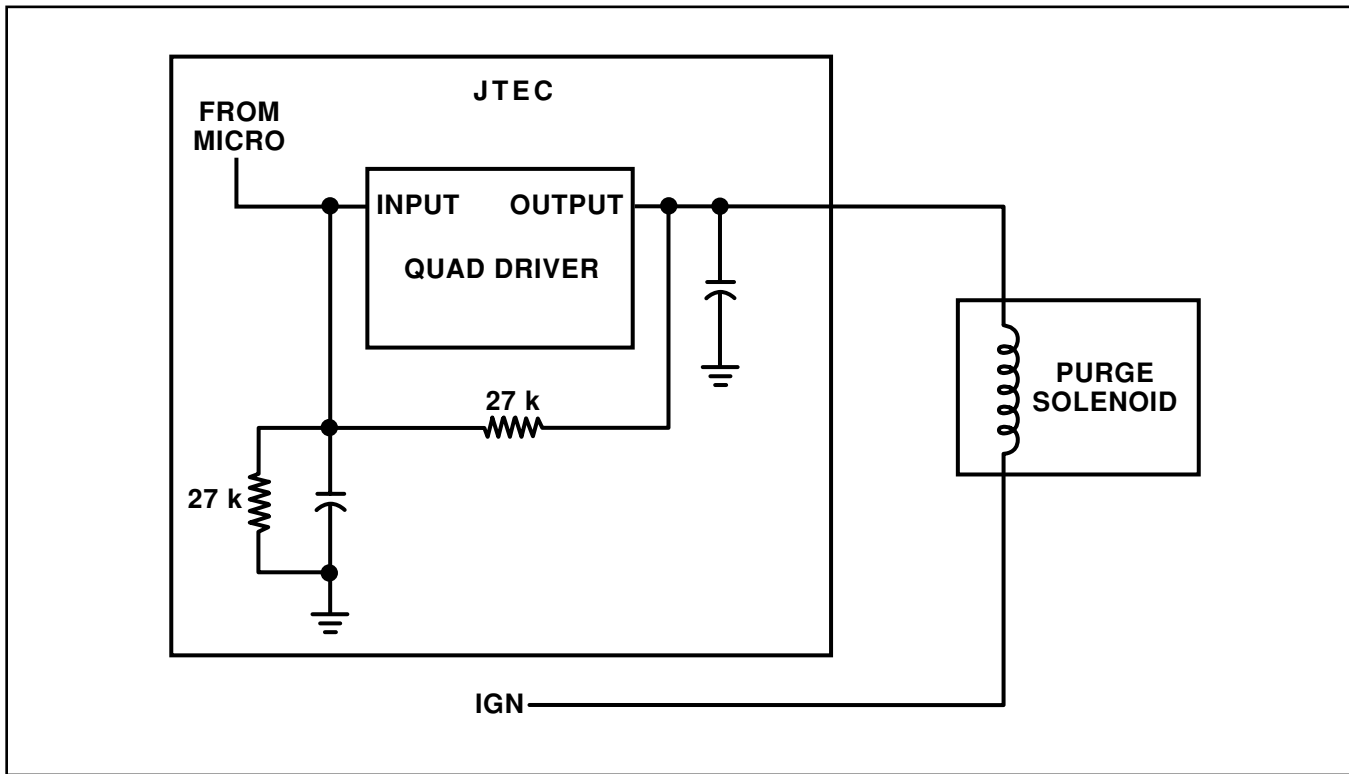

Figure 65 Duty-Cycle Purge Solenoid Control Circuit

## 8.0L - V10 Fuel Injection

### Leak Detection Pump (Beginning in 1998)

The leak detection pump is a device that pressurizes the evaporative system to determine if there are any leaks. When certain conditions are met, the PCM will activate the pump and start counting pump strokes (fig. 66). If the pump stops within a calibrated number of strokes, the system is determined to be leak free. If the pump does not stop, a DTC will be set. Refer to the OBD II course for more information.

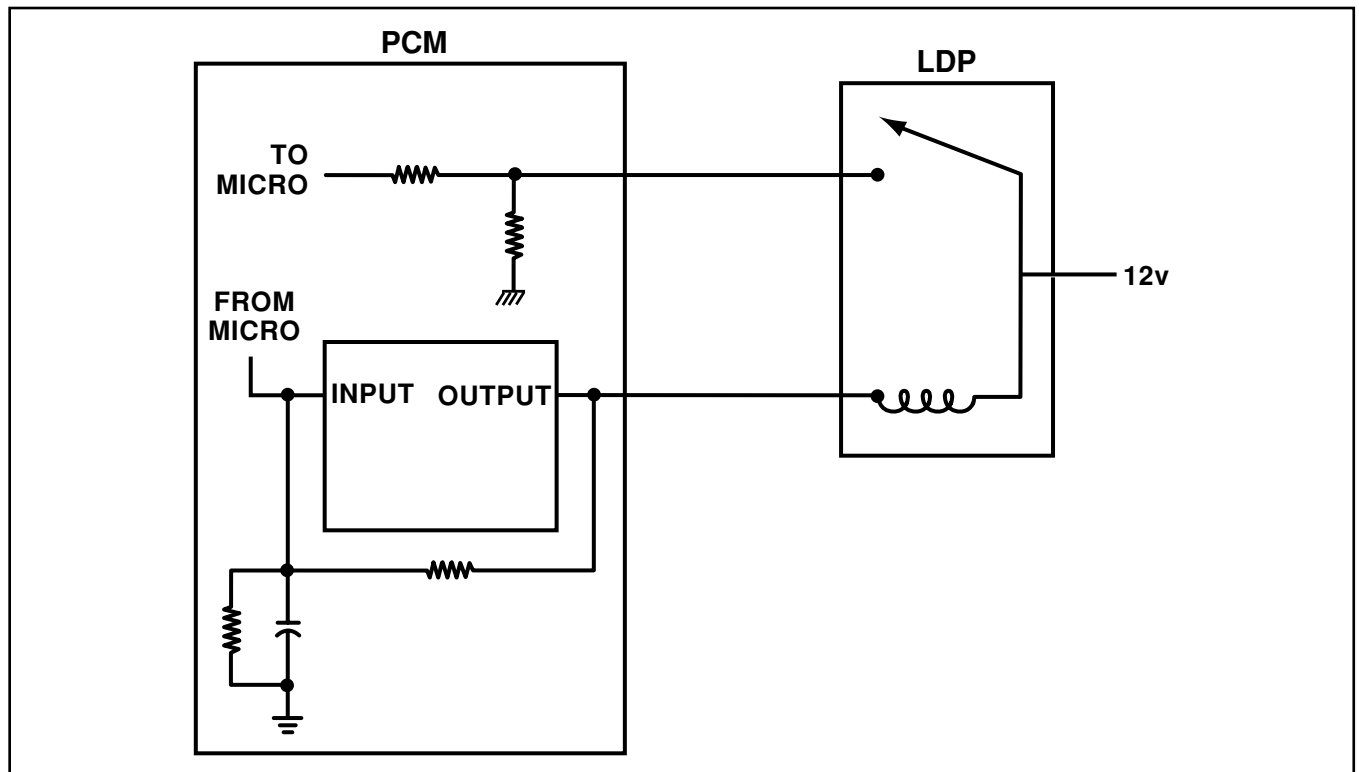

Figure 66 Leak-Detection Pump Control Circuit

## ***8.0L – V10 Fuel Injection***

### **CRANKCASE VENTILATION (CCV) SYSTEM – BR**

The 8.0L engine on the BR is equipped with a Crankcase Ventilation (CCV) system. The CCV system performs the same function as a conventional PCV system, but does not use a vacuum-controlled valve.

A gray fitting on the right cylinder head (valve) cover contains a metered orifice. The fitting is connected to the manifold vacuum. When the engine is operating, fresh air enters the engine and mixed with the crankcase vapors. Manifold vacuum draws the mixture through the fixed orifice into the intake manifold. The vapors are consumed during combustion.

# 8.0L – V10 Fuel Injection

## POSITIVE CRANKCASE VENTILATION (PCV) SYSTEM – SR

The SR 8.0L engine is equipped with a Positive Crankcase Ventilation (PCV) System.

Crankcase vapors and piston ring blow-by are removed from the engine by manifold vacuum through the Positive Crankcase Ventilation (PCV) valve (fig. 68). The vapors pass through the PCV valve into the intake manifold where they become part of the calibrated air-fuel mixture and are burned and expelled with the exhaust gases.

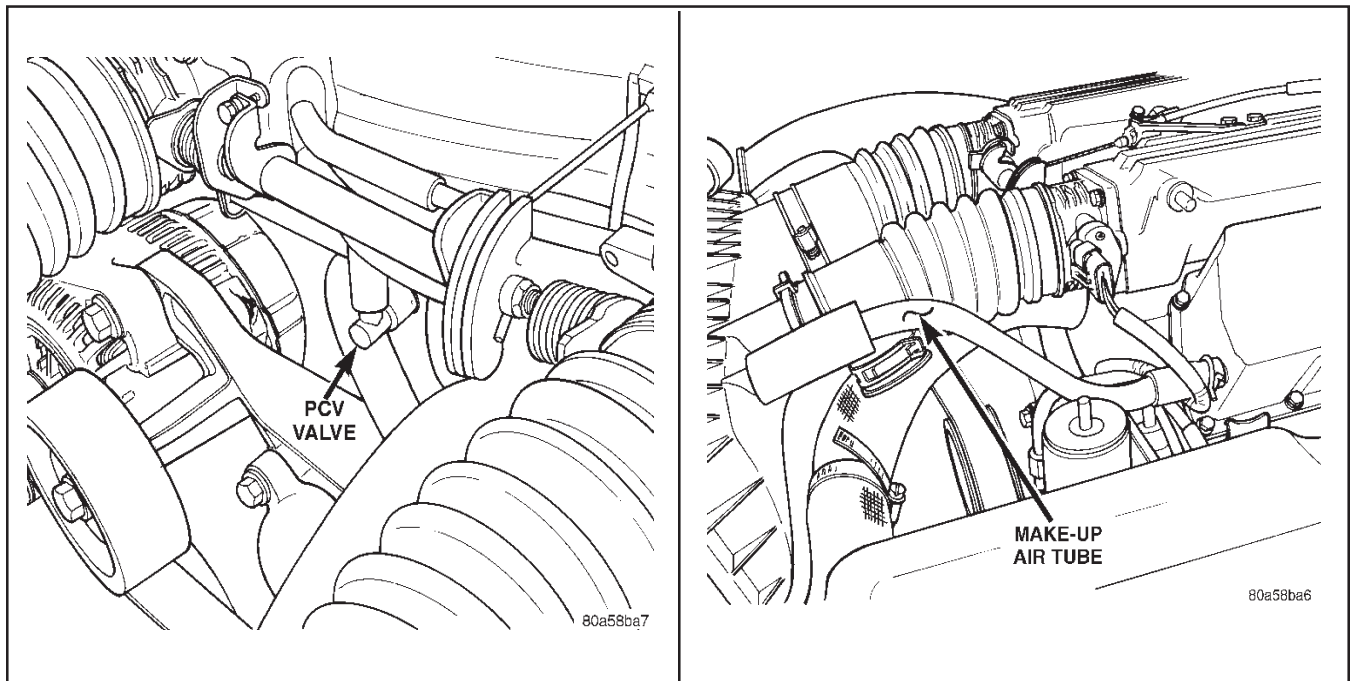

Figure 67 Positive Crankcase Ventilation (PCV) Valve

The air cleaner supplies make-up air when the engine does not have enough vapor or blow-by gases. In this system, fresh air enters the crankcase through the left valve cover.



# 8.0L – V10 Fuel Injection

## LESSON 7

### VEHICLE SPEED CONTROL SYSTEM — BR

#### System Operation

Vehicle speed control is accomplished through the PCM. The various speed control switches are a multiplex design, hard-wired to the PCM. A vacuum-operated speed control servo contains solenoids that are also controlled by the PCM.

The speed control switches provide inputs to the PCM to indicate the speed control modes: On, Off, Set, Resume, Cancel, Accelerate, Coast.

Depending on the vehicle, there is either a one- or two-switch assembly. The steering-column-mounted switches use multiplexed circuits to provide inputs to the PCM for ON/OFF, Resume/Accelerate, Set/Coast or Coast and Cancel modes (if equipped).

When speed control is selected by depressing the ON/OFF switch, the PCM allows a set speed to be stored in RAM for speed control. To store a set speed, depress the COAST/SET switch while the vehicle is moving at a speed between 35 and 85 mph. In order for the speed control to engage, the brakes cannot be applied, and the transmission must not be in Park or Neutral. If equipped with a manual transmission, it must be in either third, fourth, or fifth gear and engine rpm must be below 6,000 rpm.

The speed control can be disengaged manually by:

- Stepping on the brake pedal
- Selecting the OFF position
- Depressing the CANCEL switch (if equipped)
- Allowing vehicle to decelerate (coast) to below 25 mph
- Depressing the clutch

The speed control can also be disengaged by any of the following conditions:

- An indication of Park or Neutral
- An rpm increase without a VSS signal increase (indicates that the clutch has been disengaged)
- Excessive engine rpm (indicates that the transmission may be in a low gear)

The previous disengagement conditions are programmed for added safety.

Once the speed control has been disengaged, depressing the RES/ACCEL switch restores the vehicle to the target speed that was stored in the PCM's RAM.

#### Speed Control Switch Operation

When the ON switch is depressed, the indicator lamp comes on and the PCM sends 12 volts to the speed control servo through a set of contacts in the brake switch that are closed with the pedal at rest (fig. 67).

**NOTE:** *Depressing the ON/OFF switch will erase the set-speed stored in the PCM's RAM and turn off power to the servo.*

# 8.0L - V10 Fuel Injection

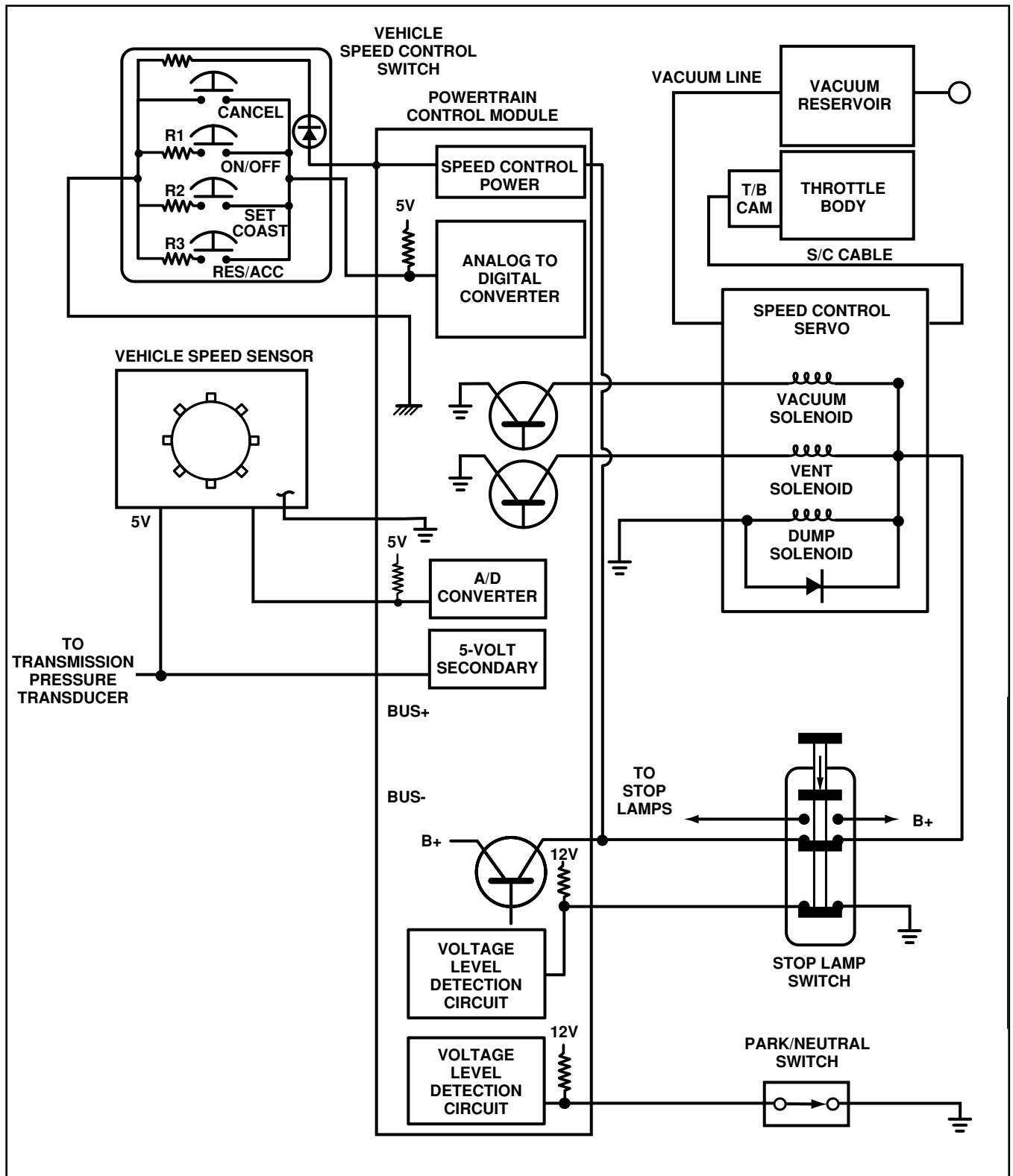

Figure 68 Typical Speed Control Circuit

## 8.0L – V10 Fuel Injection

While traveling between 35 and 85 mph, the SET button can be depressed causing a value to be stored in the RAM of the PCM.

The PCM is programmed for an acceleration feature which allows the driver to increase vehicle speed while the speed control is engaged. With the RES/ACCEL switch held closed, the vehicle accelerates slowly to the desired speed. The new target speed is stored in the RAM when the RES/ACCEL switch is released. The PCM also has a “tap-up” feature which increases vehicle speed at a rate of approximately two mph for each momentary switch activation of the RES/ACCEL switch.

There are two ways to disengage the speed control system. Depressing either the brake pedal or cancel switch will disengage the speed control system without losing the target speed in memory. When the brakes are applied, two things happen:

- The PCM recognizes an input that the brakes are applied. This causes the PCM to disengage speed control operation and retain the target speed in memory.
- The PCM interrupts the power supply to the speed control servo.

The PCM also provides a means to decelerate without disengaging speed control. To decelerate from an existing recorded target speed, depress and hold the SET/COAST switch until the desired speed is reached. Releasing the switch causes a new target speed to be stored in RAM.

### Speed Control Servo

The speed control servo consists of three solenoids:

- Vacuum
- Vent
- Dump

There is also a diaphragm with a cable attached to control the throttle linkage.

As mentioned earlier, power is supplied to the servo by the PCM through the brake switch. The PCM also controls the ground path for the vacuum and vent solenoids.

The dump solenoid is energized anytime it receives power. If power to the dump solenoid is interrupted, the solenoid dumps vacuum in the servo. This provides a safety backup to the vent and vacuum solenoids.

To operate, the vacuum and vent solenoids must be grounded at the PCM. When the PCM grounds the vacuum servo solenoid, the solenoid allows vacuum to enter the servo through a cable and pull open the throttle plate. When the PCM breaks the ground, the solenoid closes and allows no more vacuum to enter the servo. The PCM also operates the vent solenoid via ground. The vent solenoid opens and closes a passage to bleed or hold vacuum in the servo as required.

The PCM “duty cycles” the vacuum and vent solenoids to maintain the set speed or to accelerate and decelerate the vehicle. To increase throttle opening, the PCM grounds the vacuum and vent solenoids. To decrease throttle opening, the PCM removes the grounds from the vacuum and vent solenoids. When the brake is released, if vehicle speed exceeds 25 mph to resume, 30 mph to set, and the RES/ACCEL switch has been depressed, ground for the vent and vacuum circuits is restored.

# 8.0L – V10 Fuel Injection

## Speed Control Switch Input

Speed control switch input is accomplished by multiplexing, which allows the PCM to identify more than one signal from a single wire. To accomplish this, the speed control switch uses resistors that cause different voltage signals at the PCM.

### Multiplexing

The PCM sends out five volts through a fixed resistor and monitors the voltage change between the fixed resistor and the switches (Table 5). If none of the switches are depressed, the PCM will measure five volts at the sensor point (open circuit). If a switch with no resistor is closed, the PCM measures zero volts (grounded circuit). Now, if a resistor is added to a switch, then the PCM will measure some voltage, proportional to the size of the resistor. By adding a different resistor to each switch, the PCM will see a different voltage, depending on which switch is pushed.

### Brake Switch

The brake switch provides an input to the PCM to disengage the speed control when the brakes are applied (fig. 70). It is also used to influence transmission torque- converter clutch disengagement, and indicates when the driver has depressed the brake pedal. The brake switch is equipped with three sets of contacts, one normally open and the other two normally closed (brakes disengaged). The PCM sends a 12-volt signal to one of the normally closed contacts in the brake switch, which is connected to a ground. With the contacts closed, the 12-volt signal is pulled to ground, causing the signal to go low. The low-voltage signal, monitored by the PCM, indicates that the brakes are not applied. When the brakes are applied, the contacts open, causing PCM output voltage to go high, disengaging the speed control and grounding the dump solenoid.

Voltage	Resistance	BR
0	0 $\Omega$	—
1.5	945 $\Omega$	On/Off
2.9	2.9K $\Omega$	—
3.8	7K $\Omega$	Set/Coast
4.4	15.8K $\Omega$	Resume/ Accel
5.0	$\infty$	At Rest

Table 5 Speed Control Switch Voltage/Resistance Values

## 8.0L - V10 Fuel Injection

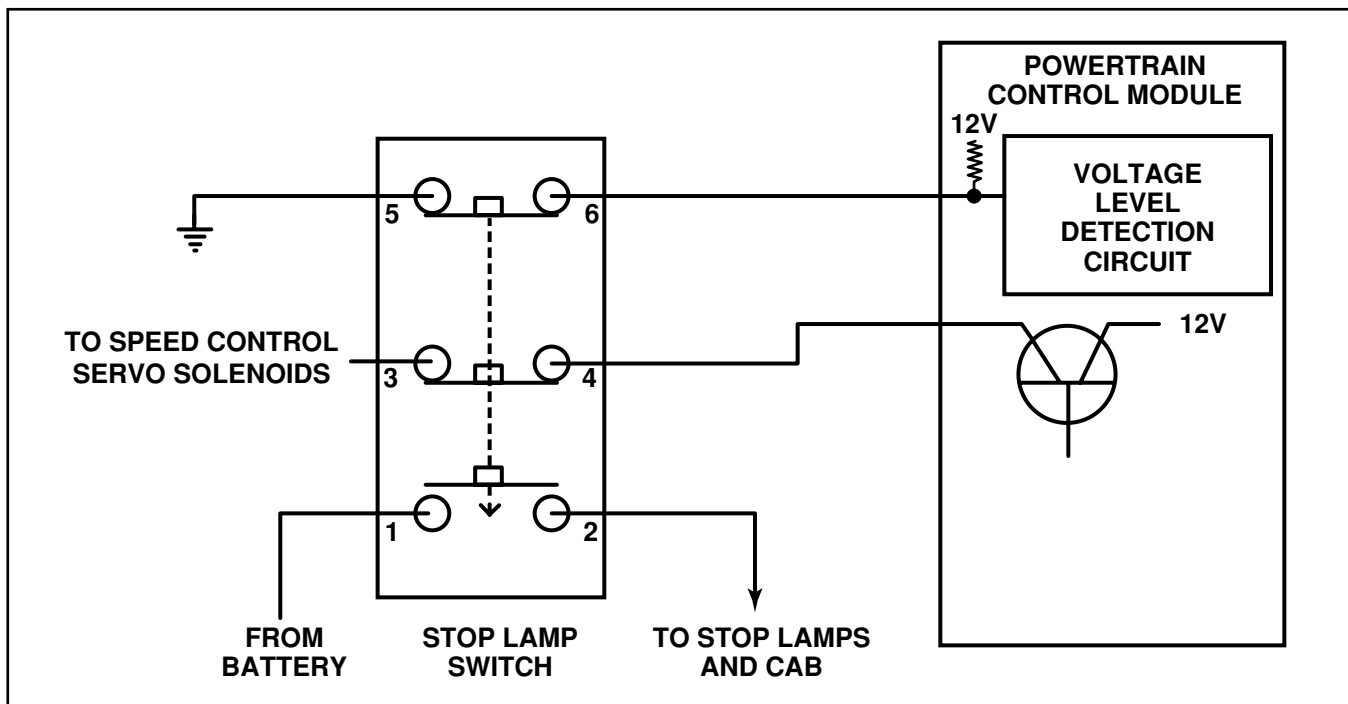

Figure 69 Brake Switch Circuit

The second set of normally closed contacts receives battery voltage anytime speed control is selected. From the brake switch, current is routed to the speed control servo solenoids. The speed control solenoids (vacuum, vent, and dump) are provided this current anytime the speed control is ON and the brakes are disengaged. When the driver applies the brakes, the contacts open and current to the solenoids is interrupted. The normally open contacts are fed battery voltage. When the brakes are applied, battery voltage is supplied to the stop lamps and the speed control relay, if so equipped. Refer to Brake Switch in the PCM Inputs section of this publication for more information.

### Adaptive Learning Strategy

An adaptive strategy compensates for vehicle-to-vehicle variations in speed control cable lengths. When the speed control is set with the vehicle operator's foot off of the accelerator pedal, the speed control senses excessive speed control cable slack and adapts. If the lift foot sets are continually used, the speed control overshoot/undershoot condition will develop.

To "unlearn" the overshoot/undershoot condition, use the following steps:

1. Press and release the set button while maintaining the desired set speed with the accelerator pedal. Do not accelerate or decelerate.
2. After waiting 10 seconds, turn the cruise control switch to the OFF position (or press the CANCEL button if equipped).

This procedure must be performed approximately 10-15 times to unlearn the overshoot/undershoot condition completely.

# 8.0L – V10 Fuel Injection

## Interactive Speed Control

“Interactive” means that communication between the PCM and the TCM portion is taking place. Interactive speed control avoids unnecessary shifting for smoother, quieter operation and, when downshifts are required, makes the shifts smoother.

## When Climbing a Grade

Interactive speed control tries to maintain the set speed by increasing the throttle opening. If opening the throttle alone cannot maintain the set speed and the vehicle speed drops more than three mph below the set speed, the transmission will downshift to third gear. If the vehicle continues to lose speed, the transmission will downshift farther, until it selects a gear that can maintain the set speed. After the vehicle encounters a less-steep grade, or has crested the grade (reduced the load on the powertrain) and can maintain the set speed at a reduced throttle position, the transmission will upshift, as appropriate, until the set speed can be maintained in Overdrive.

## Downshift Delay

Downshift delay features have been added to reduce the number and frequency of downshifts when PCM in hilly or mountainous country. While operating, interactive speed control delays or avoids downshifts up to early wide-open throttle without the PCM scheduling a downshift. If the interactive speed control is not engaged or the driver manually overrides the throttle while interactive speed control is engaged, the downshift delay feature is not activated.

Torque converter lock and unlock shifts are not affected by the downshift delay feature and will occur at the same throttle angle at a given speed regardless of whether interactive speed control operates or not.

## Grade Hunting

All vehicles equipped with a four-speed automatic transmission have a grade-hunting feature for the Third Gear-to-Overdrive upshift. The PCM identifies the powertrain loading conditions and selects the proper gear to maintain the current vehicle speed. Under moderate loading conditions, the transmission will stay in Third Gear until the top of the grade is reached or the powertrain loading is reduced. If conditions are more severe, hunting between Second and Third can occur.

Beginning with 1996, all vehicles equipped with a four-speed automatic transmission also have a grade hunting feature for the Second to Third Gear upshift. If powertrain loading is severe, the transmission may shift into Second Gear and remain there until powertrain loading is reduced, then a Second to Third Gear upshift will be scheduled. Grade hunting features always operate regardless of whether the interactive speed control is engaged. **If the interactive speed control is not engaged and powertrain loading is not reduced, the driver may have to completely lift off of the throttle before an upshift will occur.** If the driver does lift off the throttle to induce an upshift under these conditions, vehicle speed will reduce and the Overdrive-to-Third and Third-to-Second-Gear downshifts will reoccur when the throttle is reapplied. Transmission damage may result if the driver repeatedly induces grade hunting.

## **8.0L – V10 Fuel Injection**

### **When Descending a Grade (Overspeed Reduction)**

The overspeed reduction feature helps maintain the interactive speed-control set speed when descending a grade.

The PCM must sense that the interactive speed control is set. Then the interactive speed control will try to maintain the set speed by reducing or closing the throttle opening. If closing the throttle (a TPS signal of two degrees or less is considered closed throttle) is not enough to keep the vehicle within three mph over the set speed, the transmission will downshift to Third Gear. The transmission will not downshift to Third Gear to try to maintain the set speed. After the downshift to Third Gear, the interactive speed control continues normal operation. The PCM monitors conditions leading to a return to Overdrive. Once conditions are identified that grade hunting between Third and Overdrive is unlikely, the transmission will shift into Overdrive and resume normal operation.

If the downshift to Third Gear has taken place, pushing the brake pedal will disengage the interactive speed control but the transmission will stay in Third Gear. The transmission will upshift to Overdrive when the PCM receives a TPS signal of approximately five degrees or more.

If the downshift to Third Gear has taken place and the interactive speed control is still engaged, the transmission will upshift to Overdrive when the PCM receives a TPS signal of approximately eight degrees or more for approximately three seconds or more with the vehicle at the set speed or greater.

If the downshift to Third Gear has taken place and the interactive speed control is disengaged using the ON/OFF button or the CANCEL button, the transmission will upshift to Overdrive after a delay of approximately two seconds.

# 8.0L – V10 Fuel Injection

## LESSON 8

### AIR CONDITIONING CONTROLS

#### Instrument Panel A/C Select Switch

When the A/C-heater control switch is moved to an A/C position or the defroster position, the switch provides a ground for a 12-volt pull-up circuit. This tells the PCM that air conditioning has been selected.

#### Air-Conditioning Request Signal

After the driver has selected air conditioning, the PCM looks at the A/C request circuit to determine if system conditions are appropriate for compressor operation. The air-conditioning request signal provides information to the engine controller for the air-conditioning high and low pressure switches. This signal indicates that system pressures are in an acceptable range for air-conditioning application. If the PCM request circuit is pulled low with switches closed, the PCM will provide a ground for the A/C clutch relay. Normal A/C compressor cycling operation is controlled by the A/C low-pressure switch on the A/C request circuit..

The PCM on the SR also looks at the thermostatic switch. If the switch is closed, the PCM considers conditions acceptable for A/C compressor operation.

#### A/C Compressor Clutch Relay

The PCM energizes the A/C compressor clutch relay by providing a ground for the relay coil. The PCM energizes the relay only after the following conditions have been met:

- Engine speed is greater than 500 rpm
- Approximately six seconds have elapsed since the start-to-run transfer occurred
- A/C compressor has operated for a minimum time (this varies with vehicle speed and throttle position)
- Pressure on the discharge line is below 450 to 490 psi
- Suction pressure is above 34 to 38 psi
- Engine coolant temperature is below 257°F (Viper only)

Once all of the above conditions have been met and the A/C request signal indicates that A/C compressor operation is desired, the PCM energizes the A/C compressor clutch relay (fig. 70).



# 8.0L - V10 Fuel Injection

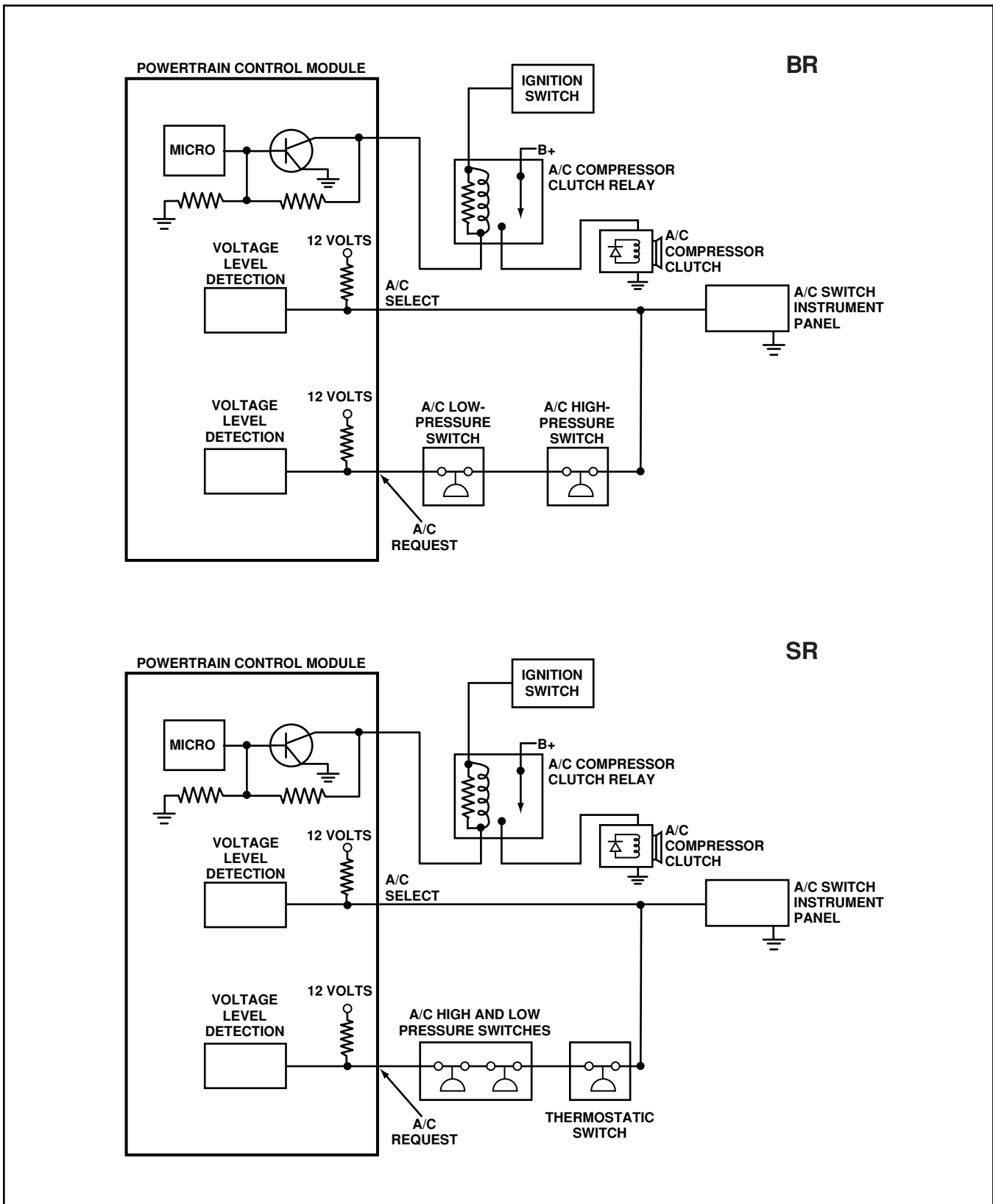

Figure 70 A/C Circuit

# 8.0L – V10 Fuel Injection

## LESSON 9

### TRANSMISSION ELECTRONICS

#### AUTOMATIC TRANSMISSION GENERAL DESCRIPTION

The 47RE is a four-speed, rear-wheel-drive (RWD), automatic transmission with an electronic governor.

Mechanical and hydraulic components are similar to those used in 42RH and 46RH transmissions. The major difference is the method of producing governor pressure for shift speed control. The 47RE uses electronic components to develop governor pressure. A mechanical governor is used in the 42RH, 46RH, and 47RH.

The RE valve body transfer plate is completely new. It has been redesigned to accept a new governor body and different hydraulic circuitry. The governor pressure solenoid valve and sensor are mounted in this body. The new transfer plate channels line pressure through the governor body to the solenoid valve. It also channels governor pressure from the solenoid valve to the governor circuit. It is the solenoid valve that develops necessary governor pressure.

The RE 4WD overdrive unit is 5-1/4 inches shorter than previous overdrive units after eliminating the mechanical governor mechanism.

#### FUNCTIONAL OPERATION

The Powertrain Control Module (PCM) controls operation of the converter clutch, overdrive clutch, and governor pressure solenoid. It determines transmission shift points based on input signals from the transmission thermistor, transmission speed sensor, engine speed sensor, vehicle speed sensor and throttle position sensor.

The PCM continuously checks for internal transmission and electrical problems, as well as some hydraulic problems. When it senses a problem, the control module stores a diagnostic trouble code. Some of these codes cause the transmission to go into “default” mode. When the PCM detects a problem, the transmission defaults to third gear. When this happens, the only transmission functions are:

- PARK and NEUTRAL.
- REVERSE.
- THIRD GEAR.
- SECOND GEAR (Manual shift).

No upshifts or downshifts are allowed. The position of the manual valve alone allows the three available ranges. Although engine performance is seriously degraded while in this mode, it allows the vehicle to be driven in for service. The transmission can be shifted manually by quickly downshifting into first to achieve first gear, then shifting to second, then to third. However, default mode will not allow fourth gear, or any converter-clutch operation.

Once the DRB III is in the transmission portion of the diagnostic program, it constantly monitors the PCM, updating the DRB III screen with switch, sensor, and input/output states, as well as displaying diagnostic trouble codes and default status.

# 8.0L – V10 Fuel Injection

## POWERFLOW

Clutch bands, overrunning clutch and planetary gear sets in the transmission unit provide First- through Third-Gear ranges in the 42RE. Fourth-Gear range is provided by the overdrive unit, which contains an overdrive clutch, direct clutch, planetary gear set and overrunning clutch.

The overdrive clutch is applied in fourth gear only. The direct clutch is applied in all gears, except fourth.

## TORQUE CONVERTER ELECTRONICS

The converter contains a converter-clutch mechanism. The converter clutch is an electronically controlled mechanism. It always engages in Fourth Gear, but in Third Gear only when the overdrive control switch is in the OFF position.

The torque converter is not a serviceable component. Replace it as an assembly when diagnosis indicates a malfunction has occurred or when a major malfunction allows debris to enter the converter.

## RECOMMENDED FLUID

The only fluid recommended for the RE transmissions is Mopar ATF Plus, type 7176. Do not use Dexron II, except in an emergency.

## ELECTRONIC GOVERNOR COMPONENTS

Governor pressure is developed and controlled electronically in the RE transmissions. Components that develop and control governor pressure are:

- Governor body.
- New design valve body transfer plate.
- Governor pressure solenoid valve.
- Governor pressure sensor (transducer).
- Transmission fluid temperature sensor (thermistor).
- Transmission output speed sensor.
- Throttle position sensor.
- Powertrain Control Module (PCM).

## Governor Pressure Solenoid Valve

The solenoid valve (fig. 71) generates the governor pressure needed for upshifts and downshifts. It is an electrohydraulic device, located in the governor body on the valve body transfer plate.

## 8.0L - V10 Fuel Injection

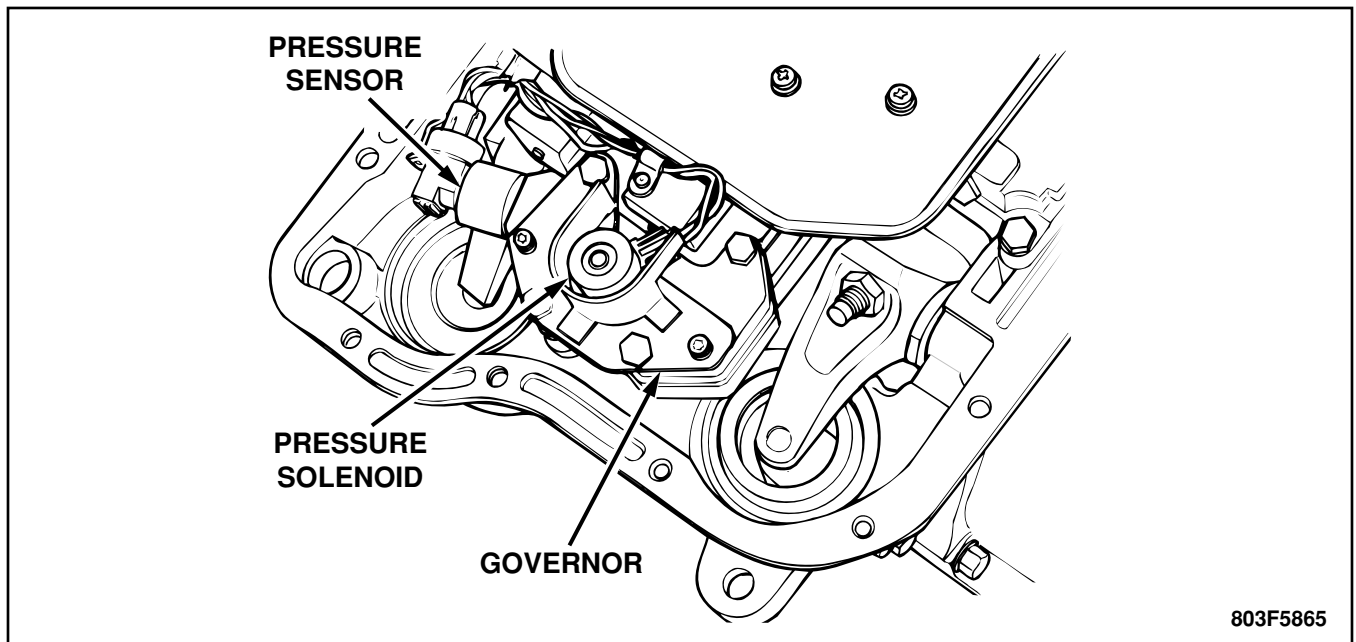

Figure 71 Governor Pressure Solenoid Location

The inlet side of the solenoid valve is exposed to normal transmission line pressure. The outlet side leads to the valve body governor circuit.

The solenoid valve regulates line pressure to produce governor pressure. The average current supplied to the solenoid valve controls governor pressure. One amp current produces zero psi governor pressure. Zero amps set the maximum governor pressure. Current is regulated by modulation of the pulse width of a 512 Hz driver frequency (512 cycles per second).

The PCM supplies electrical power to the solenoid valve. Operating voltage is 12 volts (DC) and is provided through the battery terminal on the module.

The solenoid is sensitive to polarity. The PCM energizes the solenoid, by grounding it through pin B8 (fig. 71), in the PCM.

If the voltage on the circuit (pin B8) does not match the expected voltage for approximately 5 seconds, a fault will be set.

**Caution:** *Shorting pin B8 to 12 volts will damage the PCM.*

## 8.0L – V10 Fuel Injection

### Governor Pressure Sensor

The governor pressure sensor (fig. 72) measures output pressure of the governor pressure solenoid valve.

The sensor output signal provides the necessary feedback to the PCM. This feedback is needed to accurately control pressure. The unit is an absolute pressure device and the output is calibrated to be 0.35 to 0.65 volt at 14.7 psi (normal barometric pressure). Since this is an absolute pressure device, zero psi calibration is often required to compensate for changing atmospheric pressure or altitude. This voltage measured at zero psi is referred to as zero pressure offset.

If the input voltage from this sensor remains below 0.1 volt or exceeds 4.73 volts for approximately 8 seconds, a fault will be set.

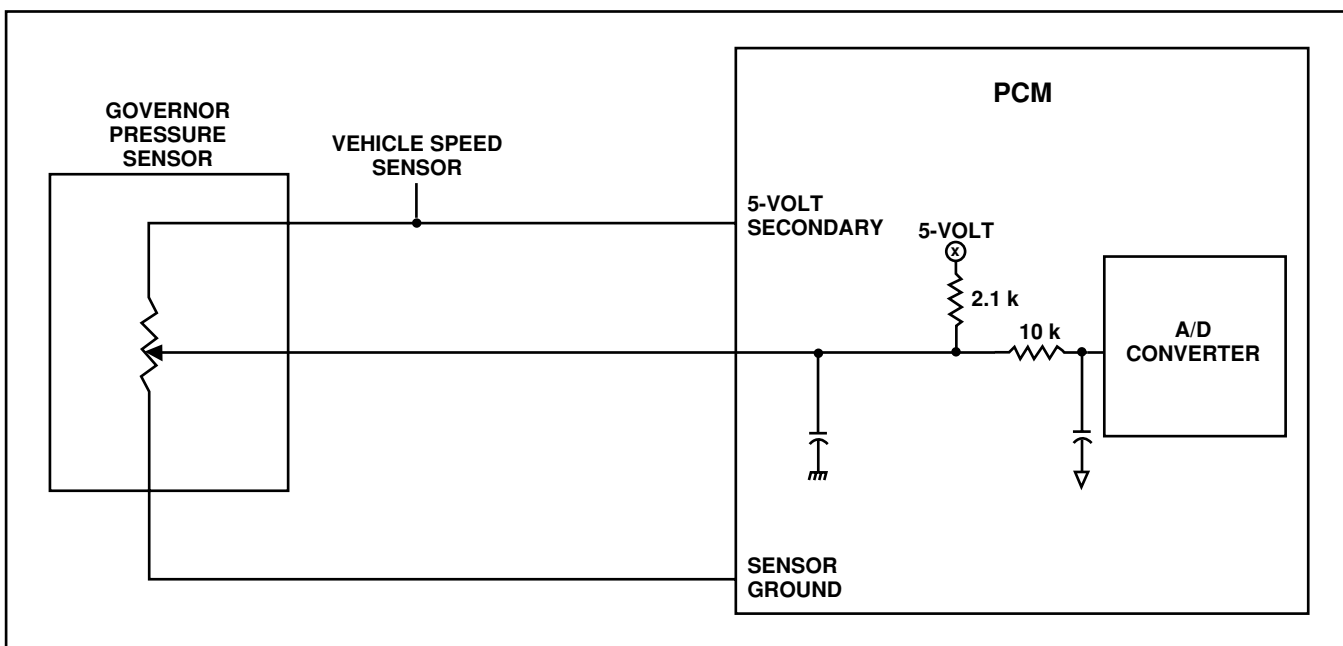

Figure 72 Governor Pressure Sensor Circuit

## 8.0L - V10 Fuel Injection

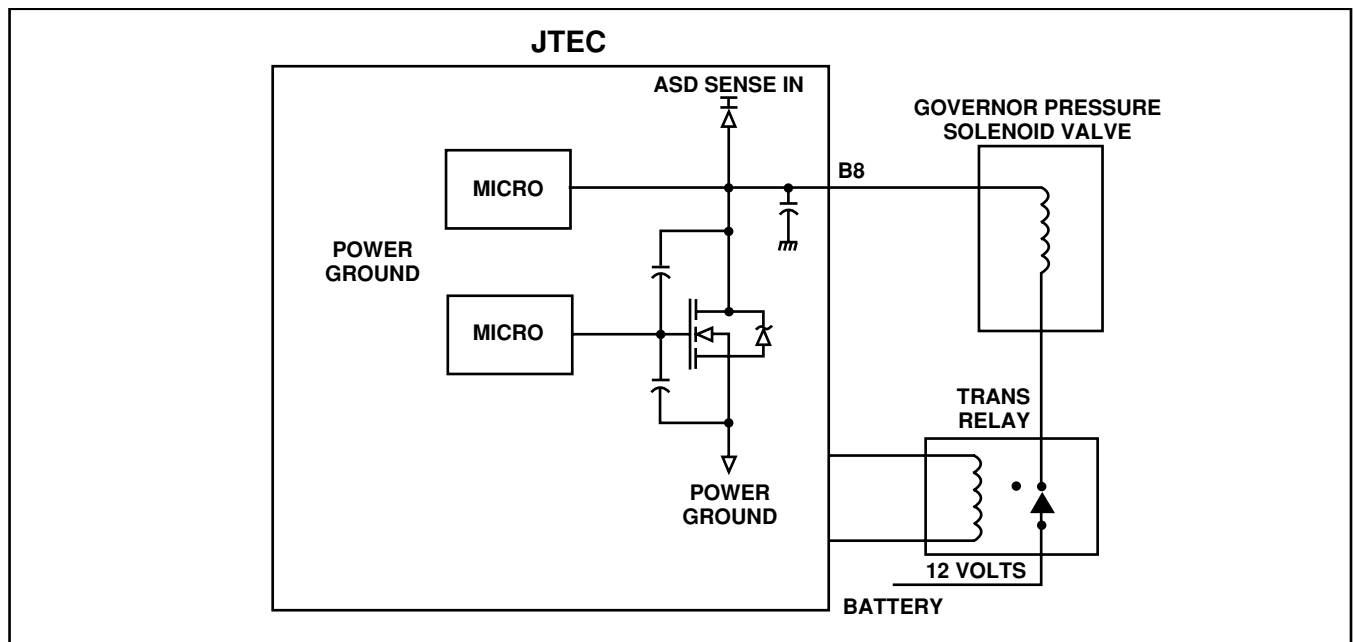

Figure 73 Governor Pressure Solenoid Valve Circuit

### Governor Body and Transfer Plate

The RE valve body has a new transfer plate designed to supply transmission line pressure to the governor pressure solenoid valve, and to return governor pressure.

The governor pressure solenoid valve is mounted to the governor body which is bolted to the lower side of the transfer plate.

### Transmission Fluid Temperature Thermistor

The thermistor supplies transmission fluid temperature readings to the PCM. Its location has moved from the solenoid assembly into the governor pressure sensor for 1996. The temperature readings are used to control engagement of the overdrive clutch, the converter clutch and governor pressure. Normal resistance value for the thermistor at room temperature is approximately 1,000 ohms.

The PCM prevents engagement of the converter clutch and overdrive clutch when fluid temperature is below approximately 50°F.

If fluid temperature exceeds 260°F, the TCM portion causes a 4-3 downshift to engage the converter clutch. Engagement is according to the Third-Gear converter-clutch engagement schedule.

The overdrive OFF lamp in the instrument panel also illuminates when the shift back to Third occurs. The transmission does not allow Fourth-Gear operation until fluid temperature decreases to approximately 230°F.

Previously, the thermistor was mounted on the underside of the converter-clutch solenoid; but 1996 models incorporate it into the governor pressure sensor connector. The thermistor is immersed in fluid at all times.

## 8.0L - V10 Fuel Injection

If the input voltage from this sensor drops below 1.5 volts or rises above 3.75 volts, a fault will be set (fig. 74).

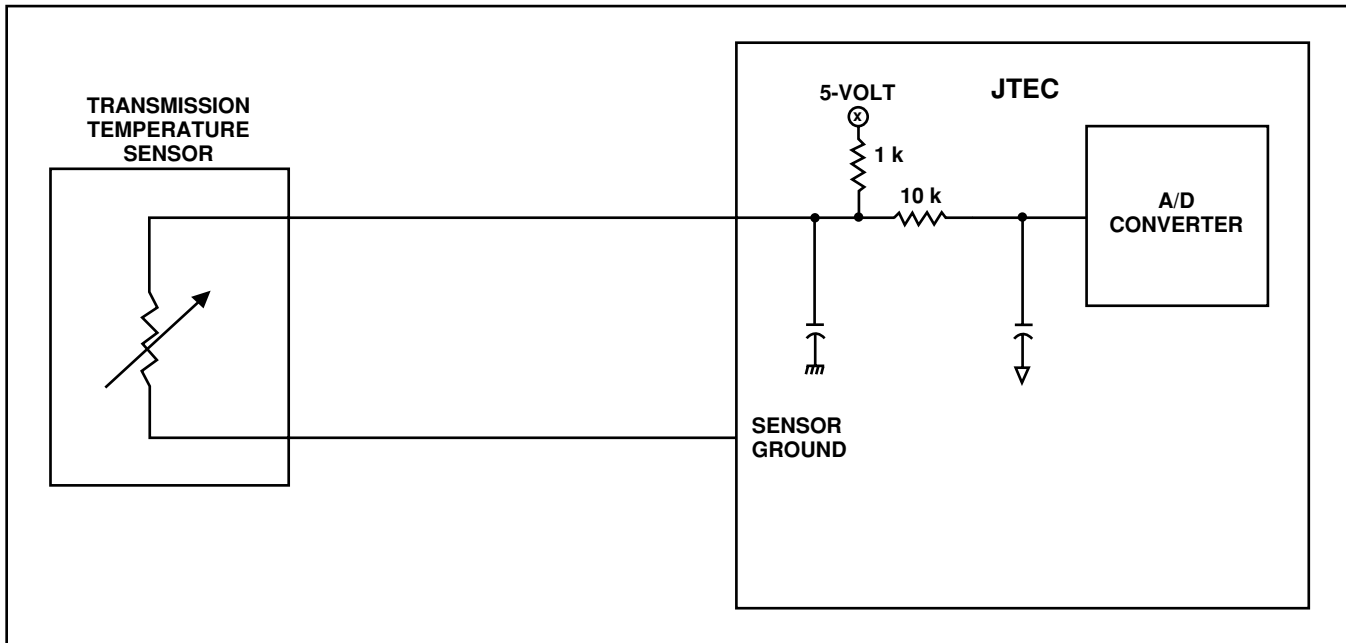

Figure 74 Transmission Temperature Sensor Circuit

### Transmission Speed Sensor

The speed sensor (fig. 75) is located in the overdrive gear case, positioned over the park gear. It monitors transmission output-shaft rotating speed. The sensor used in the 47RE transmission is the same sensor used in Chrysler 41TE and 42LE front-drive transaxles.

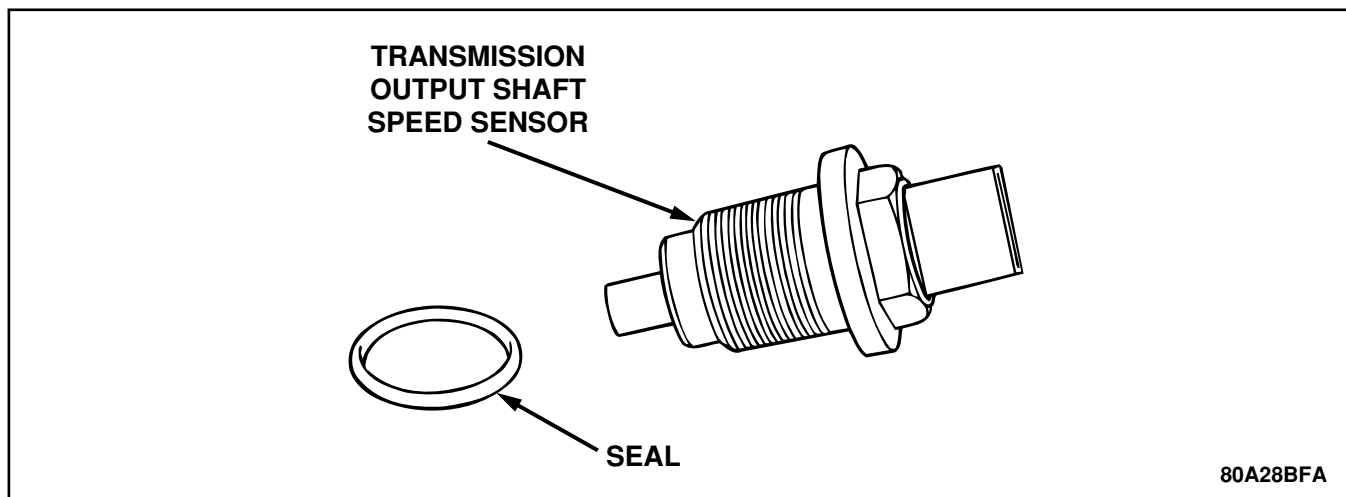

Figure 75 Speed Sensor Location

## 8.0L – V10 Fuel Injection

Speed sensor signals are triggered by the park gear lugs as they rotate past the sensor pickup face. One revolution of the output shaft produces 23 pulses. Input signals from the sensor are sent to the PCM for processing.

The vehicle speed sensor also serves as backup to the transmission speed sensor. If the output speed sensor fails, the vehicle speed sensor calculates governor pressure. Signals from this sensor are shared with the PCM.

### Throttle Position Sensor

The TPS provides throttle position input signals to the PCM. This input signal is used to determine overdrive and converter clutch shift schedule, and to select the proper governor curve.

### Powertrain Control Module (PCM)

The PCM controls operation of the converter clutch, overdrive clutch and governor pressure solenoid.

The control module determines transmission shift points, based on input signals from the transmission thermistor, transmission output-shaft speed sensor, crankshaft speed sensor, vehicle speed sensor and throttle position sensor.

### Governor Pressure Curves

Four governor pressure curves are programmed into the PCM. The different curves allow the control module to adjust governor pressure for varying conditions.

One curve is used for operation when fluid temperature is at or below 30°F.

A second curve is used when fluid temperature is at or above 31°F, during normal city or highway driving.

A third curve is used during Wide Open Throttle (WOT) operation. This curve is implemented above 85% throttle opening.

The fourth curve is used when driving with the transfer case in low range. There is no direct input into the PCM for low-range operation. Engine acceleration in low-range is more than twice the acceleration in high range. Transmission lag times become critical under this condition, requiring a separate governor pressure curve.

### Sensor Calibration

Compensation is required for performance variations of two of the input devices. Though the slope of the transfer functions is tightly controlled, offset may vary due to various environmental factors or manufacturing tolerances.

### Governor Pressure Transducer Zero-Pressure Offset

The pressure transducer is affected by barometric pressure as well as temperature. Calibration of the zero pressure offset is required to compensate for shifting output, due to these factors.



# 8.0L – V10 Fuel Injection

## Normal Governor-Pressure Transducer Calibration

Normal calibration will be performed when sump temperature is above 50°F, or in the absence of sump temperature data, after the first 10 minutes of vehicle operation. Calibration of the pressure transducer offset occurs each time the output shaft speed falls below 200 rpm. Calibration shall be repeated each three seconds when the output shaft speed is below 200 rpm.

A 0.5-second pulse of 95% duty cycle is applied to the governor pressure solenoid valve and the transducer output is read during this pulse. Averaging the transducer signal is necessary to reject electrical noise.

## Cold Governor-Pressure Transducer Calibration

Under cold conditions (below 50°F sump), the governor pressure solenoid valve response may be too slow to guarantee zero psi during the 0.5-second calibration pulse. Calibration pulses are continued during this period; but the transducer output values are discarded. Transducer offset must be read at key ON, under conditions which promote a stable reading. This value is retained and becomes the offset during the “cold” period of operation.

## Transmission Shifting

Shift valve operation in the RE transmission with the electronic governor mechanism is basically unchanged. The 1-2 and 2-3 upshift sequence occurs exactly the same as in non-electronic governor transmissions.

The valve body shift valves are still moved by a combination of throttle and governor pressure. The only real difference is that governor pressure is generated by electrical components, instead of a mechanical valve and weight assembly.

The conditions under which a shift to Fourth will occur, also remain the same:

- Shift to Third not yet completed.
- Overdrive switch is in the OFF position.
- Throttle is at 3/4 to wide-open position.
- Vehicle speed is too low for 3-4 shift to occur.
- Transmission fluid temperature is below 30°F or above 250°F.

## 8.0L – V10 Fuel Injection

### OVERDRIVE OFF SWITCH

The overdrive OFF (control) switch is located in the instrument panel. The switch is a momentary contact device that signals the PCM to toggle current status of the overdrive function (fig. 76). At key-on, overdrive operation is allowed. Pressing the switch once causes the vehicle to enter the overdrive OFF mode and illuminates the overdrive OFF switch lamp. Pressing the switch a second time restores normal overdrive operation and turns the overdrive lamp off. The overdrive OFF mode defaults to ON after the ignition switch is cycled OFF and ON. The normal position for the control switch is the ON position. The switch must be in this position to energize the solenoid and allow a 3-4 upshift. The control switch indicator light illuminates only when the overdrive switch is turned to the OFF position, or when illuminated by the PCM.

If the input voltage from this switch remains low (contacts closed) for more than five minutes, a fault will be set.

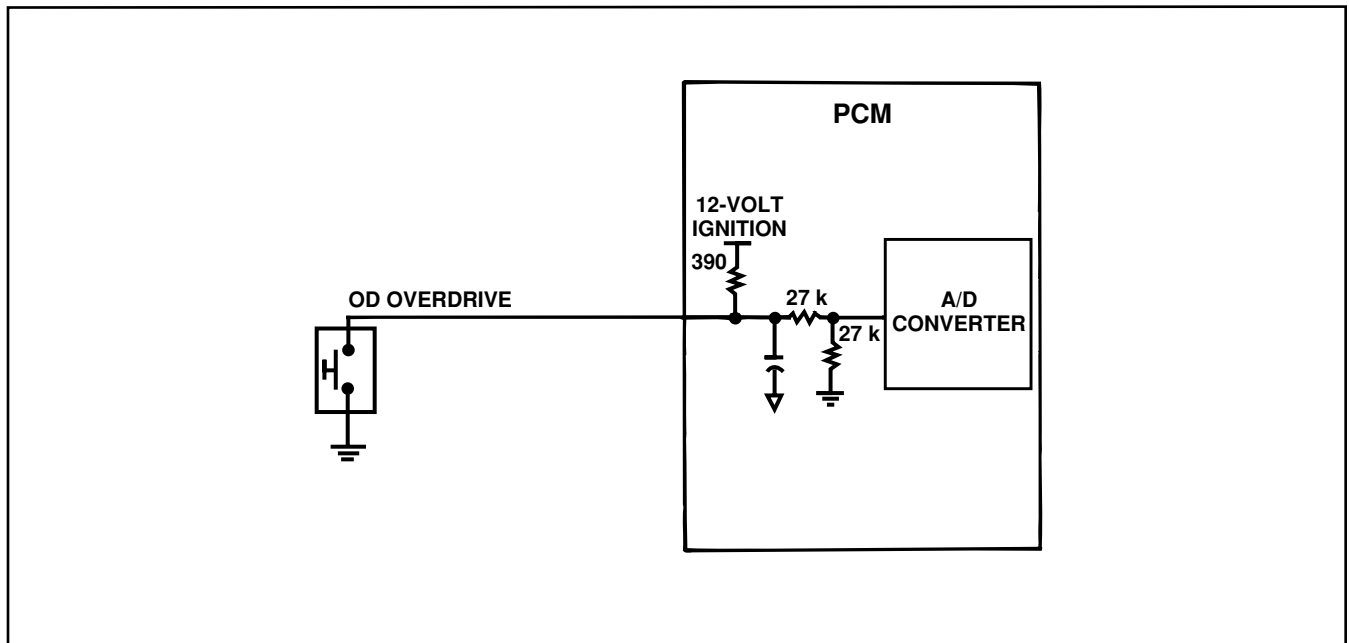

Figure 76 Overdrive Off Switch

## **8.0L – V10 Fuel Injection**

### **3-4 SHIFT SEQUENCE**

The overdrive clutch is applied in Fourth Gear only. The direct clutch is applied in all ranges except Fourth Gear. Fourth Gear overdrive range is electronically controlled and hydraulically activated.

Various sensor inputs are supplied to the PCM to operate the overdrive solenoid on the valve body. The solenoid contains a check ball that opens and closes a vent port in the 3-4 shift valve feed passage. The overdrive solenoid (and check ball) are not energized in First, Second, Third, or Reverse gear. The vent port remains open, diverting line pressure from the 2-3 shift valve away from the 3-4 shift valve. The overdrive control switch must be in the ON position to transmit overdrive status to the PCM.

A 3-4 upshift occurs only when the overdrive solenoid is energized by the PCM. The PCM energizes the overdrive solenoid during the 3-4 upshift. This causes the solenoid check ball to close the vent port allowing line pressure from the 2-3 shift valve to act directly on the 3-4 upshift valve. Line pressure on the 3-4 shift valve overcomes valve spring pressure, moving the valve to the upshift position. This action exposes the feed passages to the 3-4 timing valve, 3-4 quick fill valve, 3-4 accumulator, and ultimately to the overdrive piston. Line pressure through the timing valve moves the overdrive piston into contact with the overdrive clutch. The direct clutch is disengaged before the overdrive clutch is engaged. The boost valve provides increased fluid apply pressure to the overdrive clutch during 3-4 upshifts, and when accelerating in Fourth Gear. The 3-4 accumulator cushions overdrive clutch engagement to smooth 3-4 upshifts. The accumulator is charged at the same time as apply pressure acts against the overdrive piston.

# 8.0L – V10 Fuel Injection

## MANUAL TRANSMISSION GENERAL DESCRIPTION – VIPER

There are three components of the Borg-Warner T-56 manual transmission that are controlled by the PCM:

- Vehicle Speed Sensor (covered in detail earlier)
- Skip Shift Solenoid
- Reverse Lockout Solenoid

### SKIP SHIFT SOLENOID

The skip shift solenoid is located at the rear of the transmission housing (fig. 78). The skip shift solenoid is used to prevent the operator from shifting from first gear into second and third gear when all of the following conditions exist:

- Engine coolant temperature exceeds 41°C (106°F)
- Vehicle speed between 12 and 18 mph
- Engine operating above 608 RPM
- The PCM verified first gear speed/RPM
- TPS voltage less than 0.68 volt above closed throttle (23% throttle opening)

The skip shift solenoid receives fused ignition voltage from the fuse block (fig. 77). The PCM controls the solenoid conditions ground on and off when the conditions are met. This causes the shift lever to be redirected into fourth gear when shifting out of first gear, completely missing the second and third gear shift gate. The solenoid resets when vehicle speed drops below 2 mph and is considered completed once the vehicle is driven out of these conditions whether the transmission was shifted or not.

### REVERSE LOCKOUT SOLENOID

The reverse lockout solenoid is also located at the rear of the transmission housing (fig. 78). The reverse lockout solenoid is used to prevent the operator from shifting into reverse when vehicle speed exceeds 5 mph. When vehicle speed is less than 5 mph, the PCM provides a ground and energizes the solenoid, allowing shifting (fig. 78). When the solenoid is de-energized (above 5 mph), the transmission can't be shifted into reverse.

# 8.0L - V10 Fuel Injection

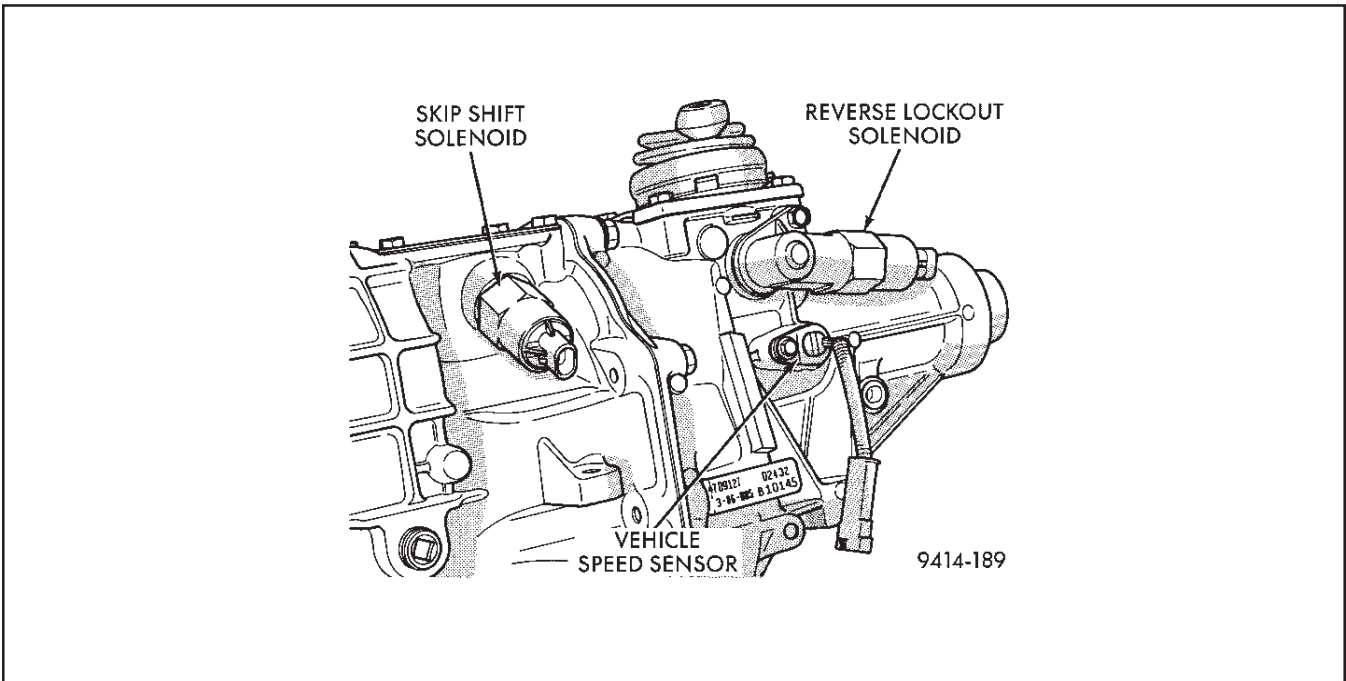

Figure 77 Manual Transmission Solenoid Locations

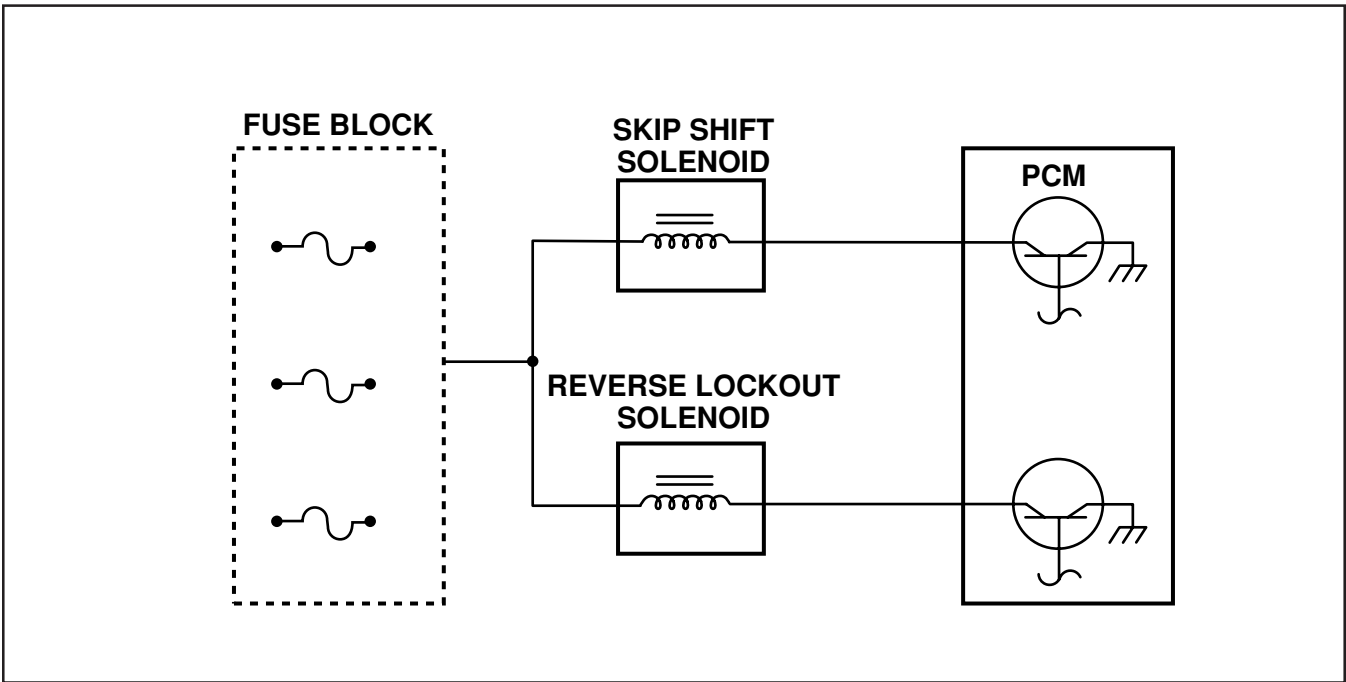

Figure 78 Skip Shift and Reverse Lockout Solenoids